

INDUCTION MOTOR

40W

□90mm

LEAD WIRE TYPE TERMINAL BOX TYPE

K9IS40N□



K9IS40N□-T, T5



SPECIFICATIONS

40W continuous rating, four poles

Model		Voltage (V)	Frequency (Hz)	Current (A)	Start T. (N·m/ Kgf·Cm)	Rated T. (N·m/ Kgf·Cm)	Speed (rpm)	Condenser (μF)
single-phase	K9I□40NJ(-T, -T5)	100	50	0.86	0.21/2.1	0.315/3.15	1250	12
			60	0.84	0.22/2.2	0.255/2.55	1550	
	K9I□40NU(-T, -T5)	110	60	0.65	0.19/1.9	0.255/2.55	1550	8
				115	0.68			
	K9I□40NL(-T, -T5)	200	50	0.4	0.22/2.2	0.315/3.15	1250	3
				60				
	K9I□40NC(-T, -T5)	220	50	0.38	0.24/2.4	0.315/3.15	1250	2.5
				60				
	K9I□40ND(-T, -T5)	230	50	0.4	0.26/2.6	0.315/3.15	1250	
				60				
	K9I□40NT(-T, -T5)	240	50	0.39	0.2/2	0.3/3	1300	2
	three-phase	K9I□40NT(-T, -T5)	200	50	0.39	1/10	0.3/3	1300
60				0.32	0.78/7.8	0.245/2.45	1600	
K9I□40NH(-T, -T5)		220	50	0.33	0.95/9.5	0.29/2.9	1350	-
				60	0.31	0.78/7.8	0.245/2.45	
K9I□40NM(-T, -T5)		230	50	0.41	1/10	0.29/2.9	1350	-
				60	0.32	0.83/8.3	0.245/2.45	
K9I□40NV(-T, -T5)		380	50	0.18	1/10	0.29/2.9	1350	-
					60	0.78/7.8	0.245/2.45	
K9I□40NQ(-T, -T5)		400	50	0.18	1.15/11.5	0.29/2.9	1350	-
				60	0.19	0.88/8.8	0.245/2.45	
K9I□40NZ(-T, -T5)		415	50	0.16	0.95/9.5	0.29/2.9	1350	-
				60	0.14	0.72/7.2	0.245/2.45	
K9I□40NZ(-T, -T5)	440	50	0.19	1/10	0.29/2.9	1350	-	
			60	0.16	0.79/7.9	0.245/2.45		1600

* □ : SHAFT SHAPE (S : STRAIGHT, G : PINION)

RATED TORQUE OF GEARHEAD

● 50Hz

unit = above : N·m / below : kgfcm

Model Motor/ Gearhead	Speed(rpm)	500	416	300	250	200	166	150	120	100	83	75	60	50	41	37	30	25	20	16	15	12.5	10	8.3	7.5
	Ratio	3	3.6	5	6	7.5	9	10	12.5	15	18	20	25	30	36	40	50	60	75	90	100	120	150	180	200
K9I□40N□(-T, -T5) K9G□B(C)	0.70	0.85	1.17	1.41	1.76	2.11	2.35	2.94	3.52	4.23	4.23	5.29	6.34	7.61	8.46	10	10	10	10	10	10	10	10	10	10
	7.0	8.5	11.7	14.1	17.6	21.1	23.5	29.4	35.2	42.3	42.3	52.9	63.4	76.1	84.6	100	100	100	100	100	100	100	100	100	100

● 60Hz

unit = above : N·m / below : kgfcm

Model Motor/ Gearhead	Speed(rpm)	600	500	360	300	240	200	180	144	120	100	90	72	60	50	45	36	30	24	20	18	15	12	10	9
	Ratio	3	3.6	5	6	7.5	9	10	12.5	15	18	20	25	30	36	40	50	60	75	90	100	120	150	180	200
K9I□40N□(-T, -T5) K9G□B(C)	0.60	0.71	0.99	1.19	1.49	1.79	1.98	2.48	2.98	3.57	3.57	4.47	5.36	6.43	7.14	8.04	10	10	10	10	10	10	10	10	10
	6.0	7.1	9.9	11.9	14.9	17.9	19.8	24.8	29.8	35.7	35.7	44.7	53.6	64.3	71.4	80.4	100	100	100	100	100	100	100	100	100

* Gearhead and decimal gearhead are sold separately.

* The code in □ of gearhead model is for gear ratio.

* ■ color indicates that the output shaft of the geared motor rotates in the same direction as the output shaft of the motor. Others indicate rotation in the opposite direction.

* If you are to have less ratio than the ratio in the table, you can install the decimal gearhead, which has one tenth of the ratio, between the gearhead and the motor. In this case, the permissible torque is 10N·m/100kgfcm.

* RPM is based on motor's synchronous rpm (50HZ:1500rpm, 60HZ:1800rpm) and calculated by dividing gear ratio. Actual rpm is 2~20% less than

indicating rpm according to load size.

GEARHEADS

DIMENSIONS

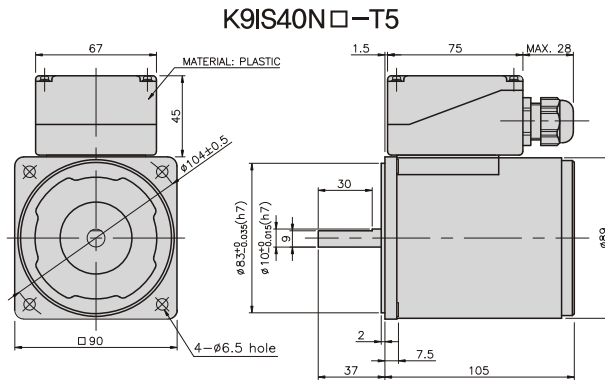
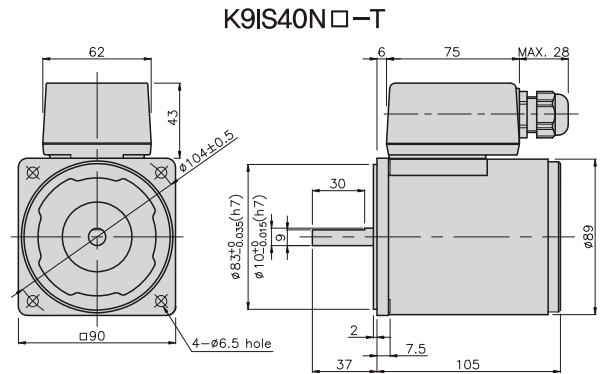
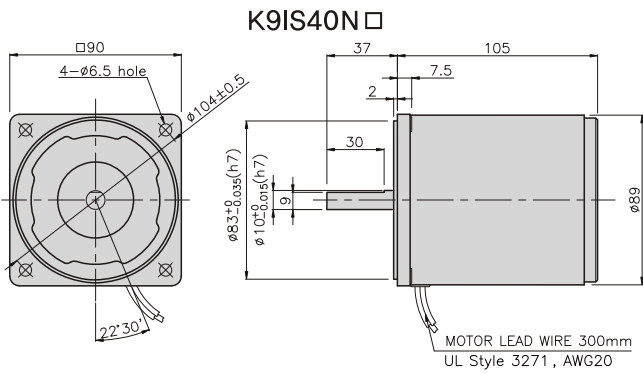

CONNECTION DIAGRAMS

K9IS40N□

single phase motor

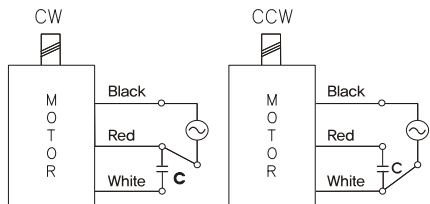

three phase motor

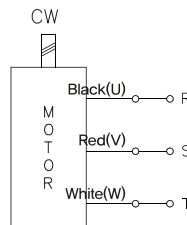

connecting two leadwires of U,V,W in turns

The direction of motor rotation is as viewed from the front shaft end of the motor

K9IS40N□-T

single phase motor

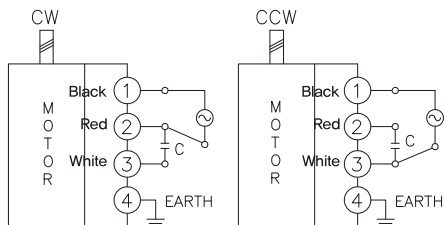

three phase motor

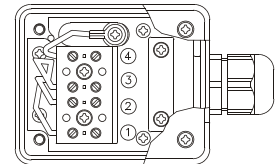
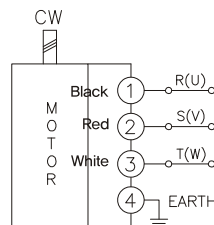

The direction of motor rotation is as viewed from the front shaft end of the motor

K9IS40N□-T5

single phase motor

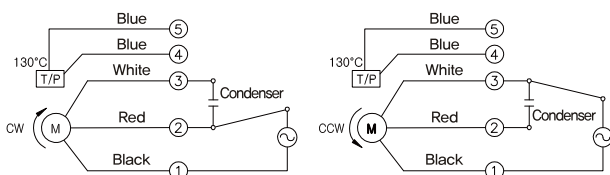

three phase motor

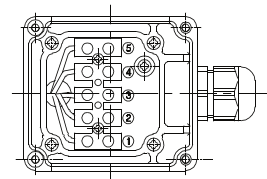
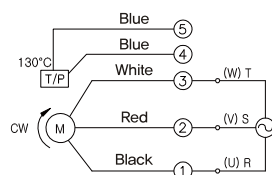

connecting two leadwires of U,V,W in turns

The direction of motor rotation is as viewed from the front shaft end of the motor

GEARHEADS

DIMENSIONS

K9G□B(C)



DECIMAL GEARHEAD

K9G10BX

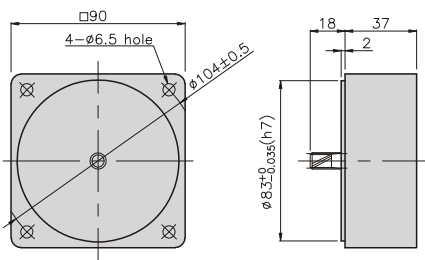

GEAR HEAD

K9G□B(C)

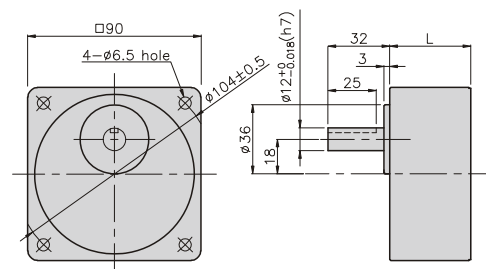

• KEY

• KEY GROOVE

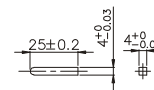

GEARHEADS

DIMENSIONS

K9IG40N□ + K9G□B(C)



K9IG40N□-T(T5) + K9G□B(C)



DIMENSION TABLE

PART No	L	Application Model	Mounting BOLT
01	42	K9G3~18B(C)	M6 P1,0 X 65
02	60	K9G20~200B(C)	M6 P1,0 X 80
03	37	K9G10BX	M6 P1,0 X 120

WEIGHT

PART	WEIGHT(kg)	
MOTOR	2,36	
DECIMAL GEAR HEAD	0,60	
GEAR HEAD	K9G3~18B(C)	0,78
	K9G20~40B(C)	1,04
	K9G50~200B(C)	1,14

K9IG40N□ + K9G□B(C)

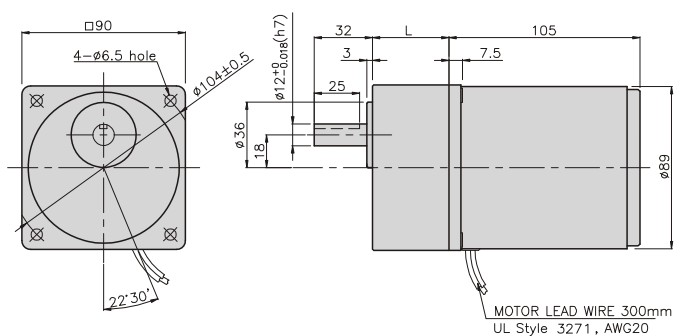

DIMENSION TABLE

PART No	L	Application Model	Mounting BOLT
01	42	K9G3~18B(C)	M5 P1,0 X 65
02	60	K9G20~200B(C)	M5 P1,0 X 80
03	37	K9G10BX	M5 P1,0 X 120

WEIGHT

PART	WEIGHT(kg)	
MOTOR	2,52	
DECIMAL GEAR HEAD	0,60	
GEAR HEAD	K9G3~18B(C)	0,78
	K9G20~40B(C)	1,04
	K9G50~200B(C)	1,14

K9IG40N□-T + K9G□B(C)

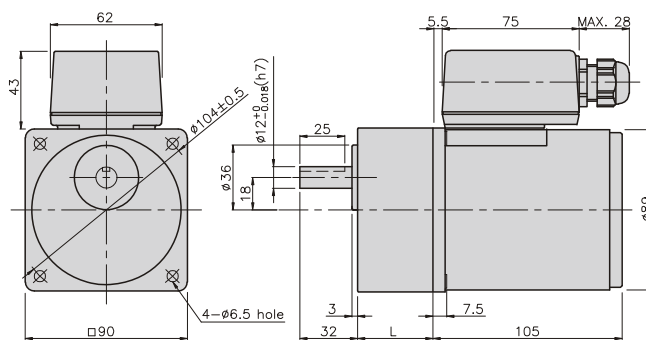

DIMENSION TABLE

PART No	L	Application Model	Mounting BOLT
01	42	K9G3~18B(C)	M5 P1,0 X 65
02	60	K9G20~200B(C)	M5 P1,0 X 80
03	37	K9G10BX	M5 P1,0 X 120

WEIGHT

PART	WEIGHT(kg)	
MOTOR	2,52	
DECIMAL GEAR HEAD	0,60	
GEAR HEAD	K9G3~18B(C)	0,78
	K9G20~40B(C)	1,04
	K9G50~200B(C)	1,14

K9IG40N□-T5 + K9G□B(C)

