



Smarter. Greener. Together.

Industrial Automation Headquarters

Delta Electronics, Inc.
Taoyuan Technology Center
18 Xinglong Road, Taoyuan District,
Taoyuan City 33068, Taiwan (R.O.C.)
TEL: 886-3-362-6301 / FAX: 886-3-371-6301

Asia

Delta Electronics (Jiangsu) Ltd.
Wujiang Plant 3
1688 Jiangxing East Road,
Wujiang Economic Development Zone
Wujiang City, Jiang Su Province,
People's Republic of China (Post code: 215200)
TEL: 86-512-6340-3008 / FAX: 86-769-6340-7290

Delta Greentech (China) Co., Ltd.
238 Min-Xia Road, Pudong District,
Shanghai, P.R.C.
Post code : 201209
TEL: 86-21-58635678 / FAX: 86-21-58630003

Delta Electronics (Japan), Inc.
Tokyo Office
2-1-14 Minato-ku Shibadaimon,
Tokyo 105-0012, Japan
TEL: 81-3-5733-1111 / FAX: 81-3-5733-1211

Delta Electronics (Korea), Inc.
1511, Byucksan Digital Valley 6-cha, Gasan-dong,
Geumcheon-gu, Seoul, Korea, 153-704
TEL: 82-2-515-5303 / FAX: 82-2-515-5302

Delta Electronics Int'l (S) Pte Ltd
4 Kaki Bukit Ave 1, #05-05, Singapore 417939
TEL: 65-6747-5155 / FAX: 65-6744-9228

Delta Electronics (India) Pvt. Ltd.
Plot No 43 Sector 35, HSIIDC
Gurgaon, PIN 122001, Haryana, India
TEL : 91-124-4874900 / FAX : 91-124-4874945

Americas

Delta Products Corporation (USA)
Raleigh Office
P.O. Box 12173, 5101 Davis Drive,
Research Triangle Park, NC 27709, U.S.A.
TEL: 1-919-767-3800 / FAX: 1-919-767-8080

Delta Greentech (Brasil) S.A
Sao Paulo Office
Rua Itapeva, 26 - 3º andar Edificio Itapeva One-Bela Vista
01332-000-São Paulo-SP-Brazil
TEL: +55 11 3568-3855 / FAX: +55 11 3568-3865

Europe

Deltronics (The Netherlands) B.V.
Eindhoven Office
De Witbogt 20, 5652 AG Eindhoven, The Netherlands
TEL: 31-40-2592850 / FAX: 31-40-2592851

*We reserve the right to change the information in this catalogue without prior notice.

5012606102
2015-07



1CE2

Delta Economy Vector Control Drive C200 Series User Manual



Delta Economy Vector Control Drive C200 Series User Manual



www.deltaww.com

 **DELTA**
Smarter. Greener. Together.

Preface

Thank you for choosing DELTA's high-performance VFD-C200 Series. The VFD-C200 Series is manufactured with high-quality components and materials and incorporate the latest microprocessor technology available.

This manual is to be used for the installation, parameter setting, troubleshooting, and daily maintenance of the AC motor drive. To guarantee safe operation of the equipment, read the following safety guidelines before connecting power to the AC motor drive. Keep this operating manual at hand and distribute to all users for reference.

To ensure the safety of operators and equipment, only qualified personnel familiar with AC motor drive are to do installation, start-up and maintenance. Always read this manual thoroughly before using VFD-C200 series AC Motor Drive, especially the DANGER and CAUTION notes. Failure to comply may result in personal injury and equipment damage. If you have any questions, please contact your dealer.

PLEASE READ PRIOR TO INSTALLATION FOR SAFETY.



- ☑ AC input power must be disconnected before any wiring to the AC motor drive is made.
- ☑ Even if the power has been turned off, a charge may still remain in the DC-link capacitors with hazardous voltages before the POWER LED is OFF. Please do not touch the internal circuit and components.
- ☑ There are highly sensitive MOS components on the printed circuit boards. These components are especially sensitive to static electricity. Please do not touch these components or the circuit boards before taking anti-static measures. Never reassemble internal components or wiring.
- ☑ Ground the AC motor drive using the ground terminal. The grounding method must comply with the laws of the country where the AC motor drive is to be installed.
- ☑ DO NOT install the AC motor drive in a place subjected to high temperature, direct sunlight and inflammables.



- ☑ Never connect the AC motor drive output terminals U/T1, V/T2 and W/T3 directly to the AC mains circuit power supply.
- ☑ Only qualified persons are allowed to install, wire and maintain the AC motor drives.
- ☑ Even if the 3-phase AC motor is stop, a charge may still remain in the main circuit terminals of the AC motor drive with hazardous voltages.
- ☑ If the AC motor drive is stored in no charge condition for more than 3 months, the ambient temperature should not be higher than 30 °C. Storage longer than one year is not recommended, it could result in the degradation of the electrolytic capacitors.

NOTE

The content of this manual may be revised without prior notice. Please consult our distributors or download the most updated version at <http://www.delta.com.tw/industrialautomation>

Table of Contents

Chapter 1 Introduction	1-1
Chapter 2 Installation	2-1
Chapter 3 Wiring	3-1
Chapter 4 Main Circuit Terminals	4-1
Chapter 5 Control Terminals	5-1
Chapter 6 Optional Accessories	6-1
Chapter 7 Specification	7-1
Chapter 8 Digital Keypad	8-1
Chapter 9 Summary of Parameter Settings	9-1
Chapter 10 Description of Parameter Settings	10-1
Chapter 11 Warning Codes	11-1
Chapter 12 Fault Codes and Descriptions	12-1
Chapter 13 CANopen Overview	13-1
Chapter 14 PLC Function	14-1
Chapter 15 Suggestions and Error Corrections for Standard AC Motor Drives	15-1
Appendix A. Publication History	A-1

Application **Control BD V1.05**

Chapter 1 Introduction

Receiving and Inspection

After receiving the AC motor drive, please check for the following:

1. Please inspect the unit after unpacking to assure it was not damaged during shipment. Make sure that the part number printed on the package corresponds with the part number indicated on the nameplate.
2. Make sure that the voltage for the wiring lie within the range as indicated on the nameplate. Please install the AC motor drive according to this manual.
3. Before applying the power, please make sure that all the devices, including power, motor, control board and digital keypad, are connected correctly.
4. When wiring the AC motor drive, please make sure that the wiring of input terminals “R/L1, S/L2, T/L3” and output terminals “U/T1, V/T2, W/T3” are correct to prevent drive damage.
5. When power is applied, select the language and set parameter groups via the digital keypad (KPE-LE02). When executes trial run, please begin with a low speed and then gradually increases the speed until the desired speed is reached.

Nameplate Information

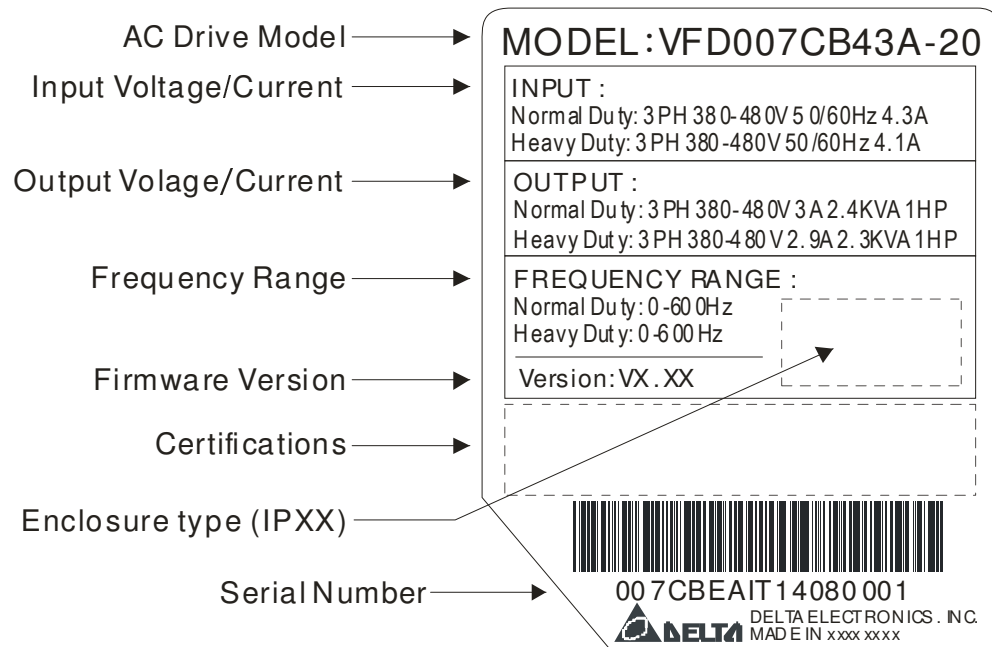

Model Name

VFD 007 CB 43 A - 21

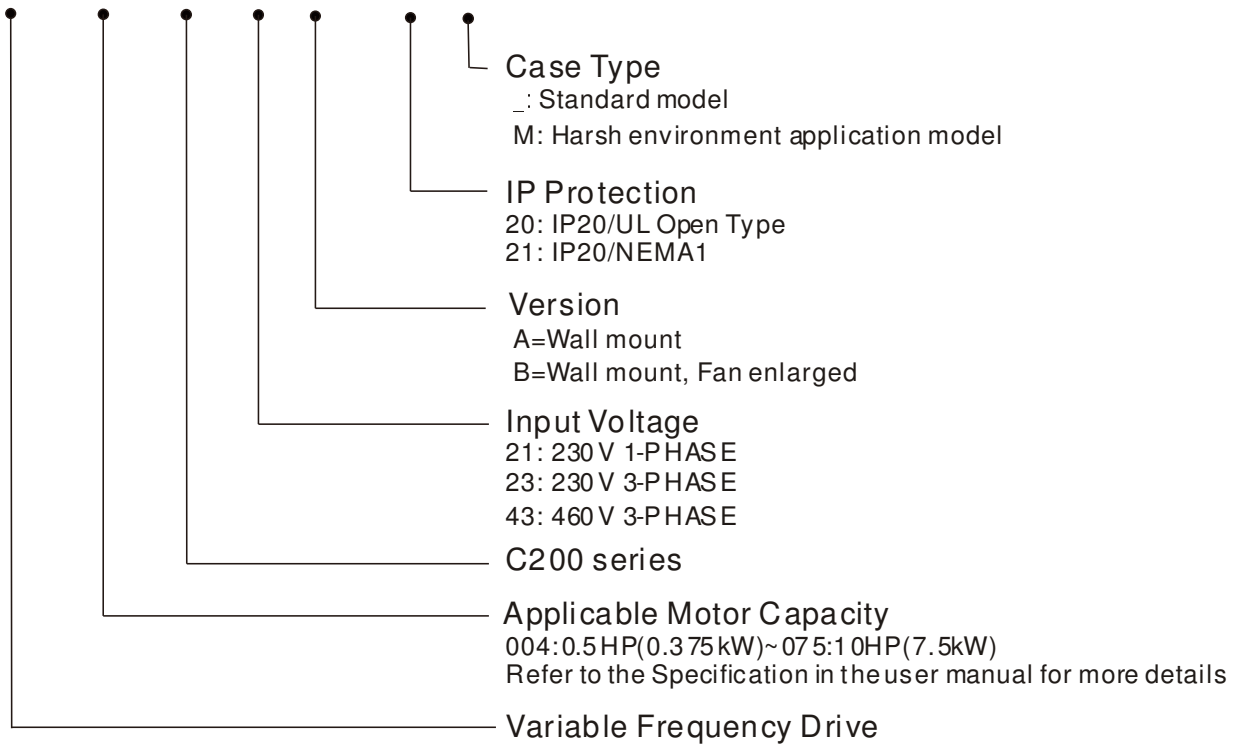

RFI Jumper

RFI Jumper: The AC motor drive may emit the electrical noise. The RFI jumper can enable internal filter to suppress the interference (Radio Frequency Interference) on the power line.

Frame A0~A Screw Torque: 8~10kg-cm(6.9-8.7 lb -in.)

Loosen the screws and remove the MOV-PLATE. Fasten the screws back to the original position after MOV-PLATE is removed.

Frame A0

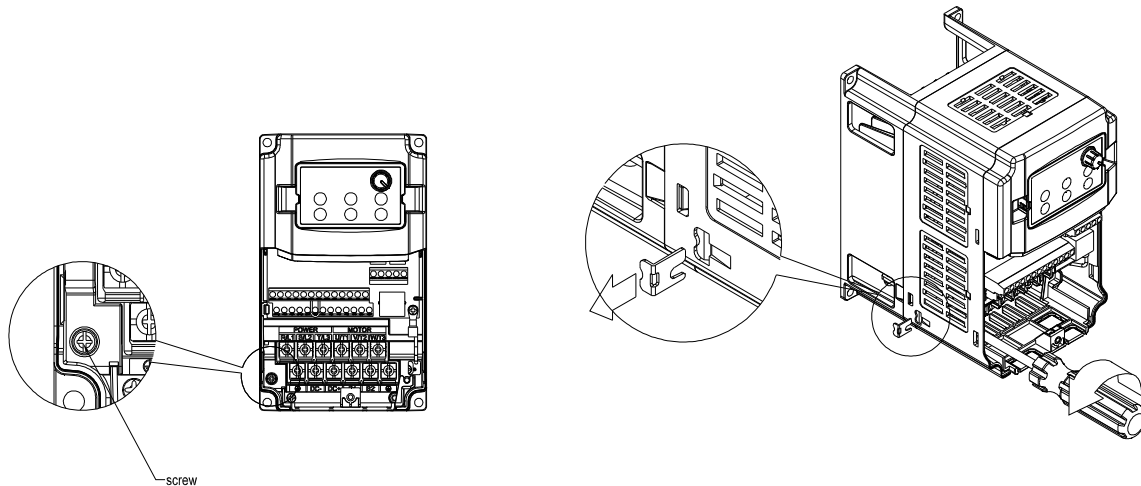

Frame A

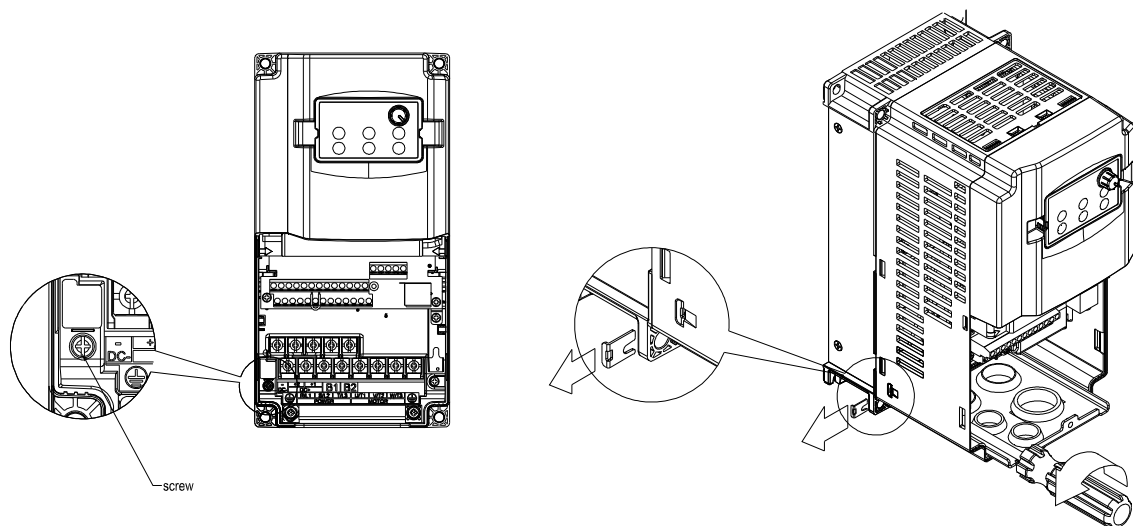

Isolating main power from ground:

When the power distribution system of the AC motor drive is a floating ground system (IT) or an asymmetric ground system (TN), the RFI jumper must be removed. After removing RFI jumper, the path between the system's mechanical frame and the central circuits will be cut off to avoid damaging the central circuits and (according to IEC 61800-3) reduce the ground leakage current.

Important points regarding ground connection

- ☑ To ensure the safety of personnel, proper operation, and to reduce electromagnetic radiation, the AC motor drive must be properly grounded during installation.
- ☑ The diameter of the cables must meet the size specified by safety regulations.
- ☑ The earthing cable must be connected to the ground of the AC motor drive to meet safety regulations.
- ☑ The earthing cable can only be used as the ground for equipment when the aforementioned points are met.
- ☑ When installing multiple sets of AC motor drive, do not connect the grounds of the AC motor drive in series. As shown below

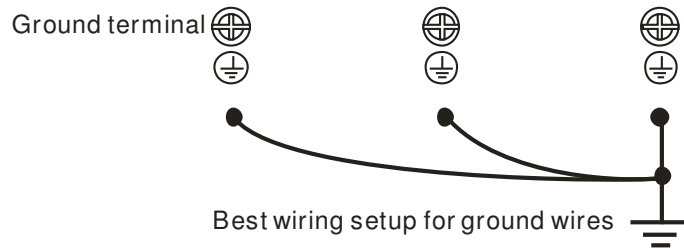

Pay particular attention to the following points:

- ☑ After turning on the main power, do not remove the RFI jumper while the power is on.
- ☑ Make sure the main power is turned off before removing the RFI jumper.
- ☑ Removing the RFI jumper will also cut off the conductivity of the capacitor. Gap discharge may occur once the transient voltage exceeds 1000V.

If the RFI jumper is removed, there will no longer be reliable electrical isolation. In other words, all controlled input and outputs can only be seen as low-voltage terminals with basic electrical isolation. Also, when the internal RFI capacitor is cut off, the AC motor drive will no longer be electromagnetic compatible.

- ☑ The RFI jumper may not be removed if the main power is a grounded power system.
- ☑ The RFI jumper may not be removed while conducting high voltage tests. When conducting a high voltage test to the entire facility, the main power and the motor must be disconnected if leakage current is too high.

Floating Ground System(IT Systems)

A floating ground system is also called IT system, ungrounded system, or high impedance/resistance (greater than 30Ω) grounding system.

- ☑ Disconnect the ground cable from the internal EMC filter.
- ☑ In situations where EMC is required, check whether there is excess electromagnetic radiation affecting nearby low-voltage circuits. In some situations, the adapter and cable naturally provide enough suppression. If in doubt, install an extra electrostatic shielded cable on the power supply side between the main circuit and the control terminals to increase security.
- ☑ Do not install an external RFI/EMC filter, the EMC filter will pass through a filter capacitor, thus connecting power input to ground. This is very dangerous and can easily damage the AC motor drive.

Asymmetric Ground System(Corner Grounded TN Systems)

Caution: Do not cut the RFI jumper while the input terminal of the AC motor drive carries power.

In the following four situations, the RFI jumper must be removed. This is to prevent the system from grounding through the RFI capacitor, damaging the AC motor drive.

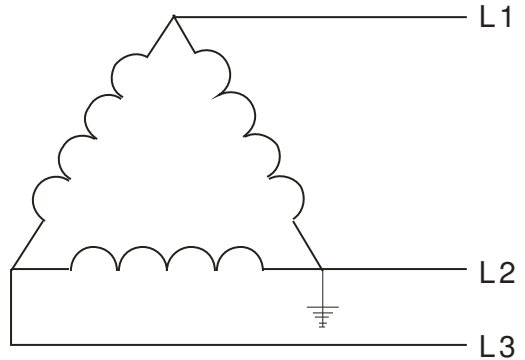
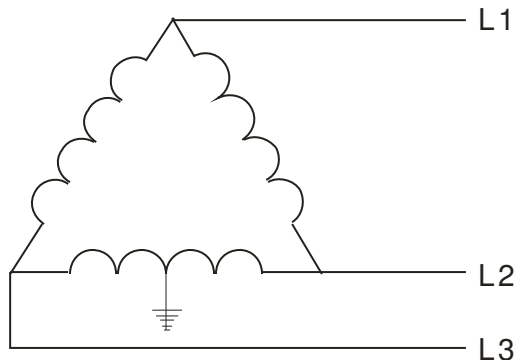
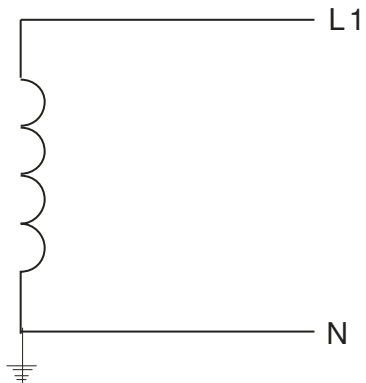
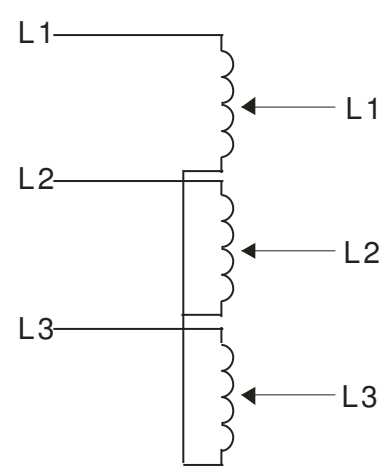
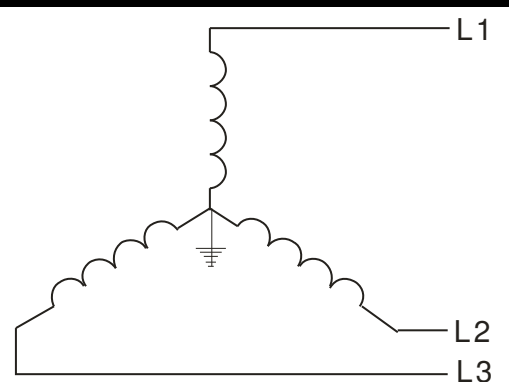
RFI jumper must be removed	
<p>1 Grounding at a corner in a triangle configuration</p> 	<p>2 Grounding at a midpoint in a polygonal configuration</p> 
<p>3 Grounding at one end in a single-phase configuration</p> 	<p>4 No stable neutral grounding in a three-phase autotransformer configuration</p> 
RFI jumper can be used	
<p>Internal grounding through internal RFI filter, which reduces electromagnetic radiation. In a situation with higher requirements for electromagnetic compatibility, and using a symmetrical grounding power system, an EMC filter can be installed. As a reference, the diagram on the right is a symmetrical grounding power system.</p>	

Dimensions

Frame A0

VFD004CB21A-20; VFD007CB21A-20; VFD004CB23A-20; VFD007CB23A-20;

VFD007CB43A-20; VFD015CB43A-20

VFD015CB23A-20 (Fan Module included)

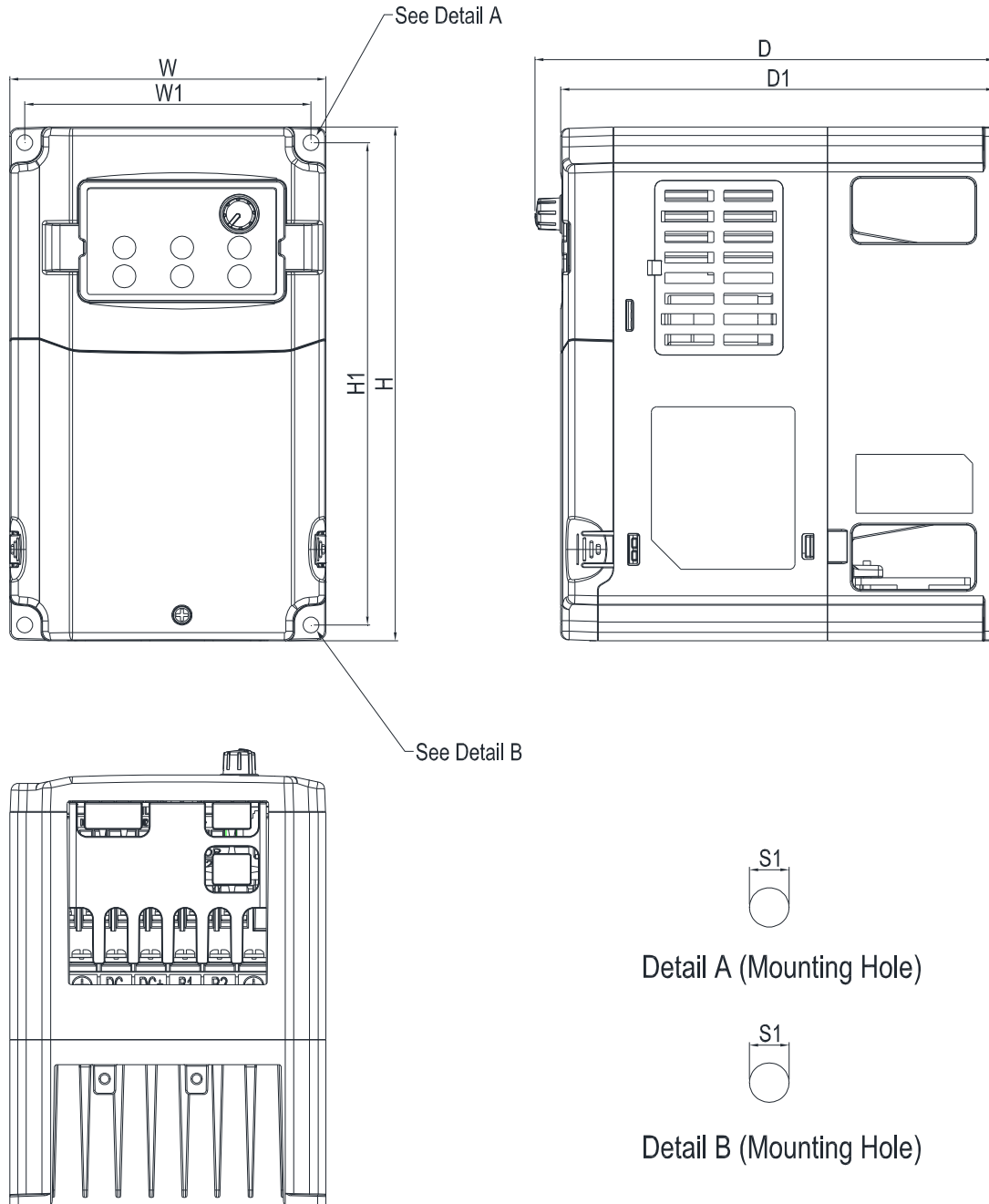

Unit: mm [inch]

Frame	W	W1	H	H1	D	D1	S1	Φ1	Φ2	Φ3
A0	110.0 [4.33]	99.6 [3.92]	180.0 [7.09]	169.0 [6.65]	160.0 [6.30]	151.0 [5.94]	5.5 [0.22]	-	-	-

Frame A0

VFD015CB21A-20; VFD022CB21A-20; VFD022CB23A-20; VFD037CB23A-20;
 VFD022CB43A-20; VFD037CB43A-20

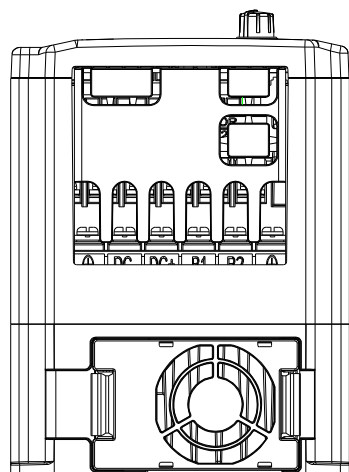
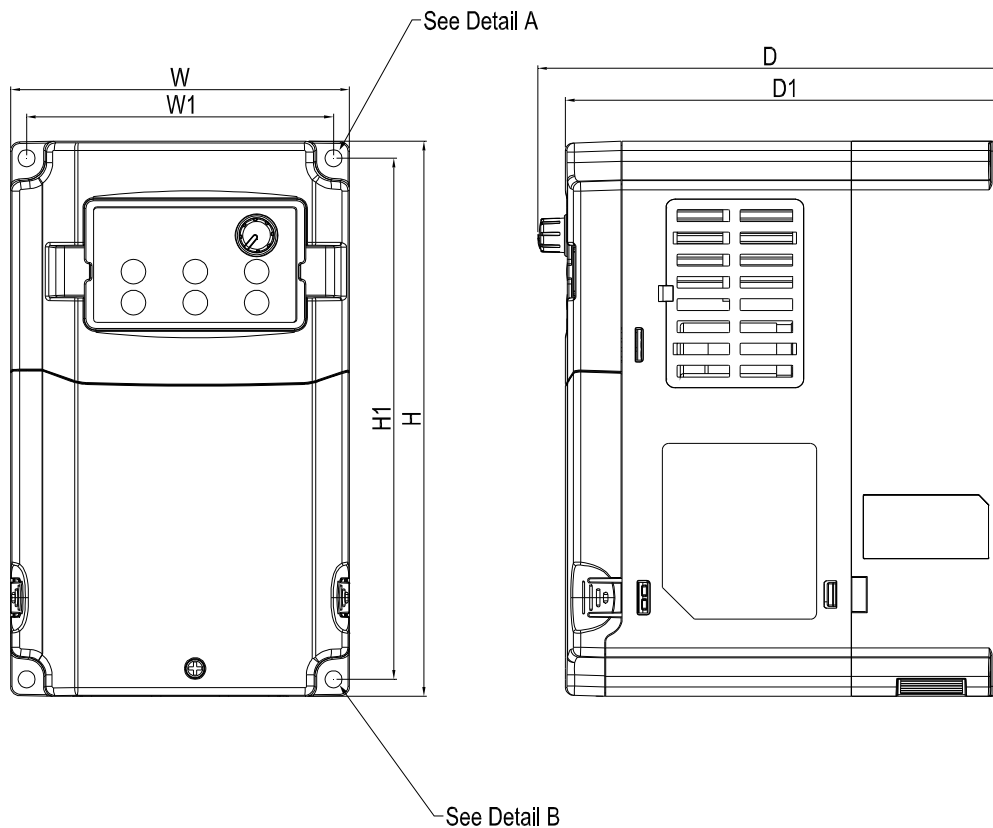

Detail A (Mounting Hole)



Detail B (Mounting Hole)

Frame	W	W1	H	H1	D	D1	S1	Φ1	Φ2	Φ3
A0	110.0 [4.33]	99.6 [3.92]	180.0 [7.09]	169.0 [6.65]	151.0 [5.94]	142.0 [5.59]	5.5 [0.22]	-	-	-

Unit: mm [inch]

Frame A0

VFD004CB21A-21; VFD007CB21A-21; VFD004CB23A-21; VFD007CB23A-21;
 VFD007CB43A-21; VFD015CB43A-21
 VFD015CB23A-21 (Fan Module included)

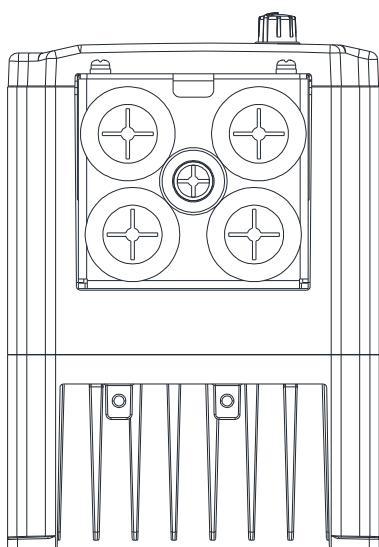
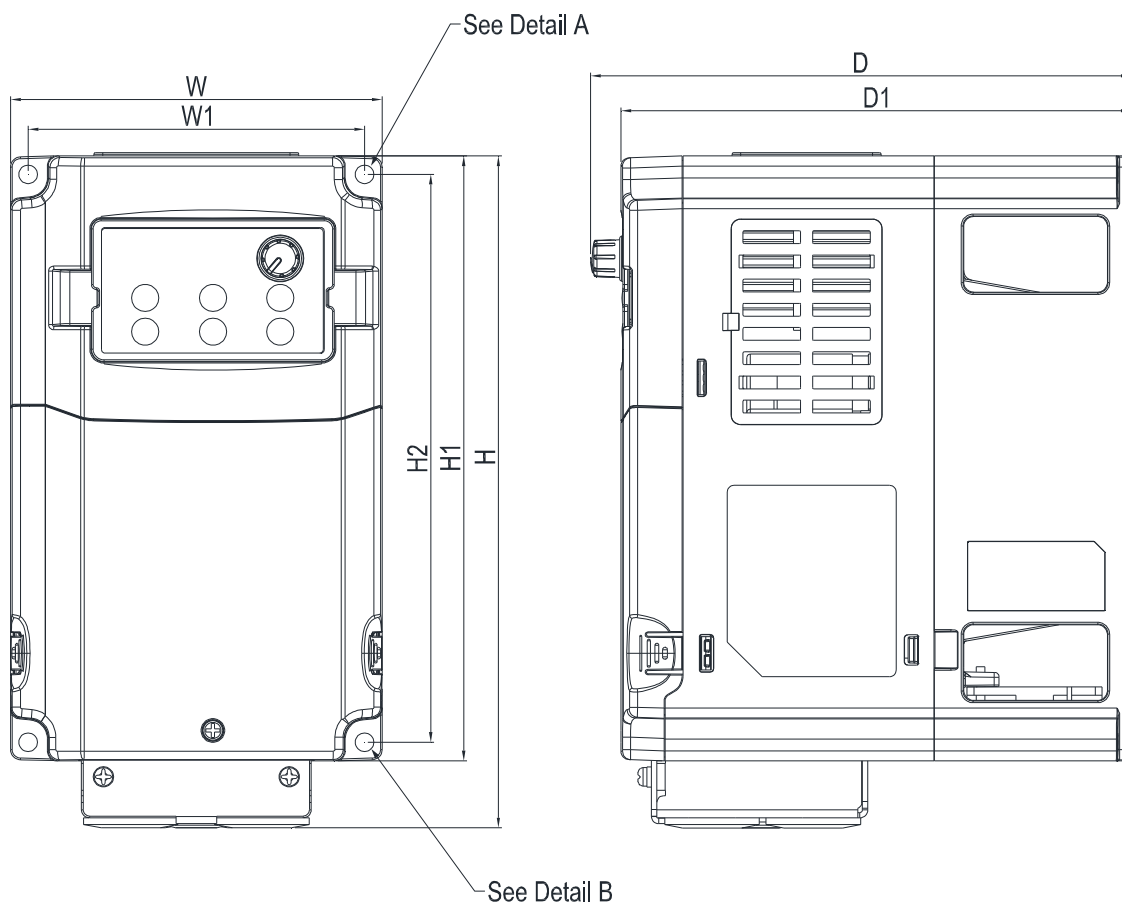

Detail A (Mounting Hole)



Detail B (Mounting Hole)

Unit: mm [inch]

Frame	W	W1	H	H1	H2	D	D1	S1	Φ1	Φ2	Φ3
A0	110.0 [4.33]	99.6 [3.92]	200.0 [7.87]	180.0 [7.09]	169.0 [6.65]	160.0 [6.30]	151.0 [5.94]	5.5 [0.22]	-	-	-

Frame A0

VFD015CB21A-21; VFD022CB21A-21; VFD022CB23A-21; VFD037CB23A-21;
 VFD022CB43A-21; VFD037CB43A-21

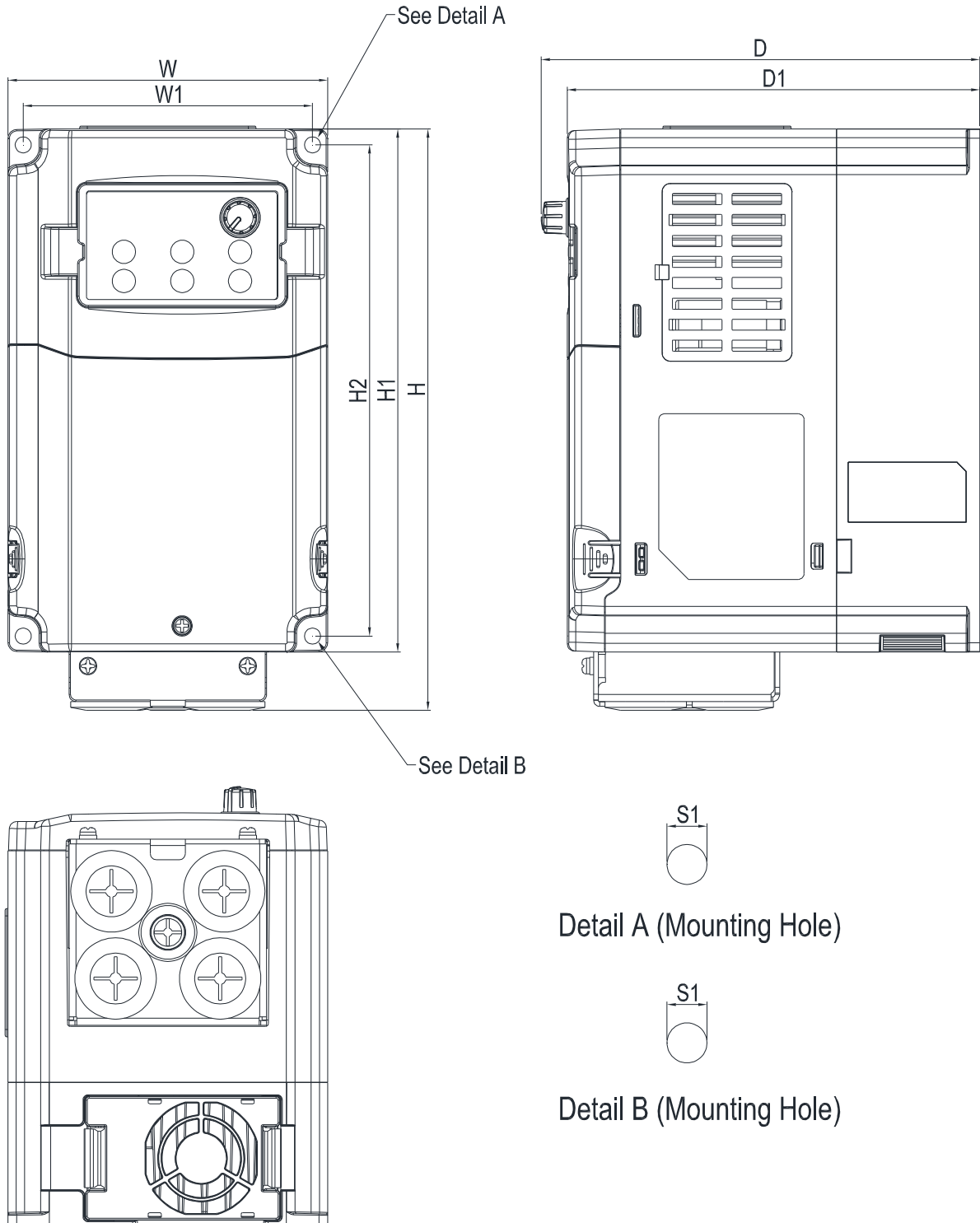

Unit: mm [inch]

Frame	W	W1	H	H1	H2	D	D1	S1	Φ1	Φ2	Φ3
A0	110.0 [4.33]	99.6 [3.92]	200.0 [7.87]	180.0 [7.09]	169.0 [6.65]	151.0 [5.94]	142.0 [5.59]	5.5 [0.22]	-	-	-

Frame A0

VFD004CB21A-21M; VFD007CB21A-21M; VFD004CB23A-21M; VFD007CB23A-21M;
 VFD007CB43A-21M; VFD015CB43A-21M
 VFD015CB23A-21M (Fan Module included)

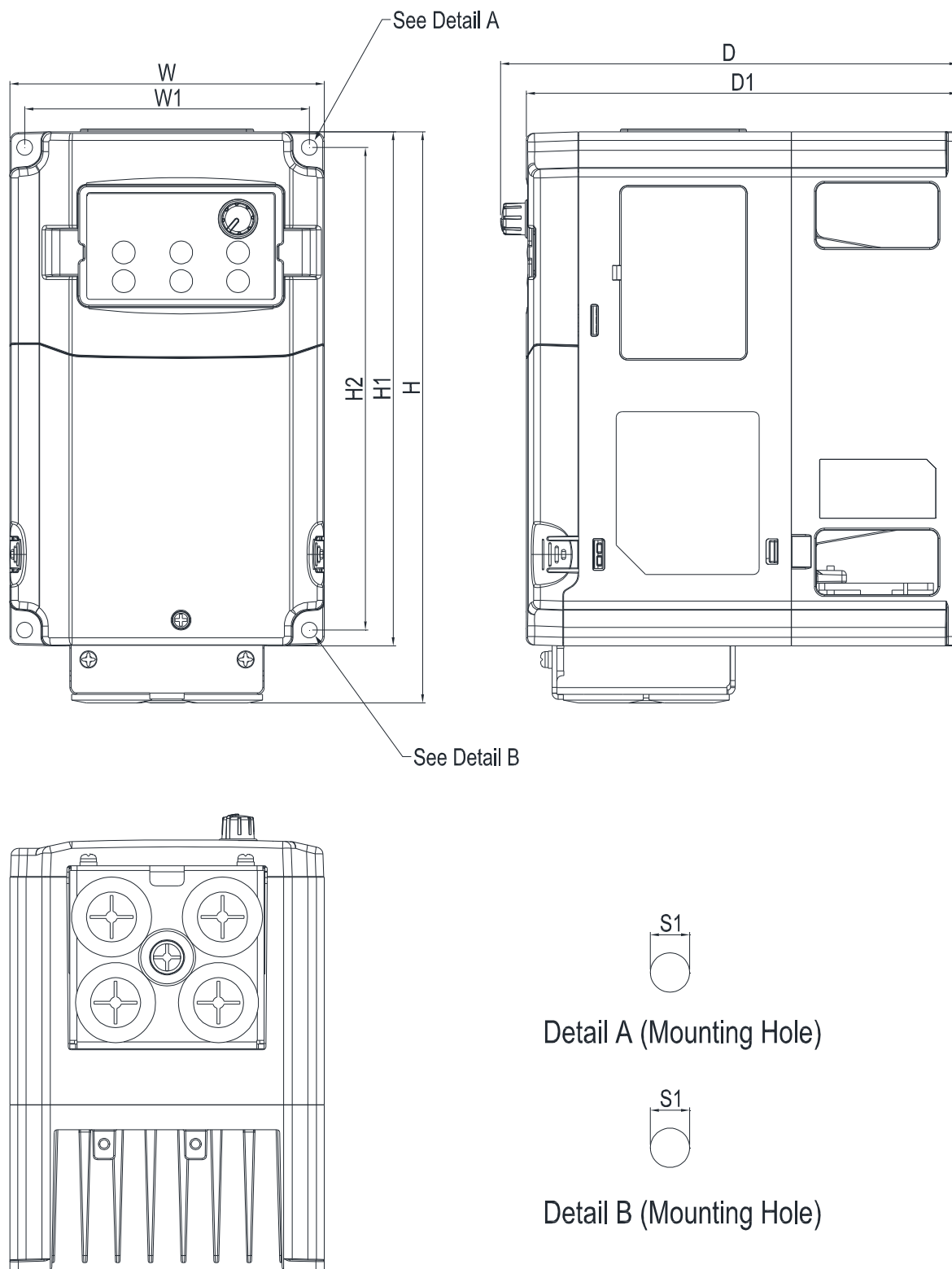

Unit: mm [inch]

Frame	W	W1	H	H1	H2	D	D1	S1	Φ1	Φ2
A0	110.0 [4.33]	99.6 [3.92]	200.0 [7.87]	180.0 [7.09]	169.0 [6.65]	160.0 [6.30]	151.0 [5.94]	5.5 [0.22]	-	-

Frame A0

VFD015CB21A-21M; VFD022CB21A-21M; VFD022CB23A-21M; VFD037CB23A-21M;
 VFD022CB43A-21M; VFD037CB43A-21M

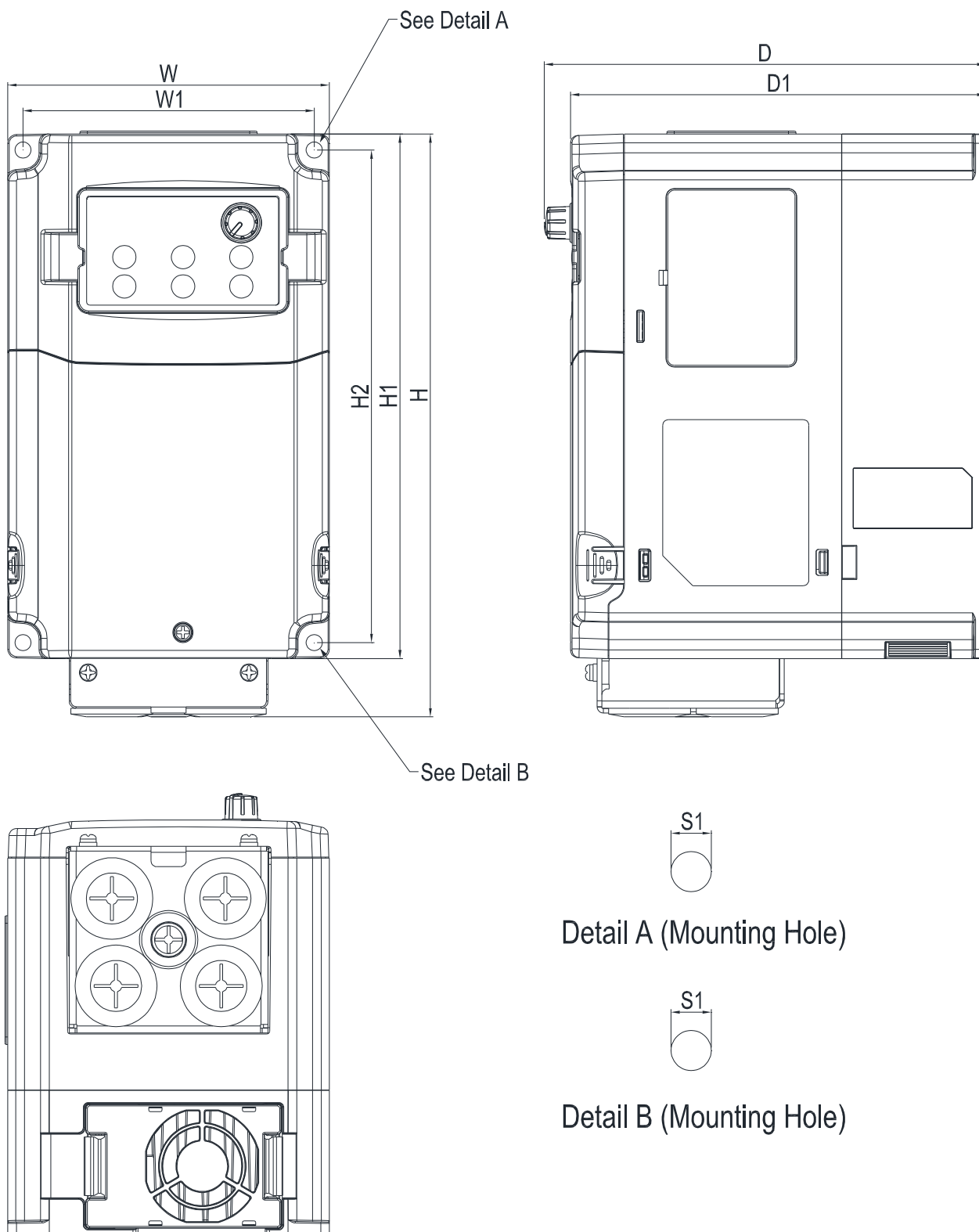

Unit: mm [inch]

Frame	W	W1	H	H1	H2	D	D1	S1	Φ1	Φ2
A0	110.0 [4.33]	99.6 [3.92]	200.0 [7.87]	180.0 [7.09]	169.0 [6.65]	151.0 [5.94]	142.0 [5.59]	5.5 [0.22]	-	-

Frame A0 (Fan enlarged)

VFD022CB43B-20; VFD037CB43B-20

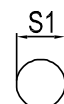
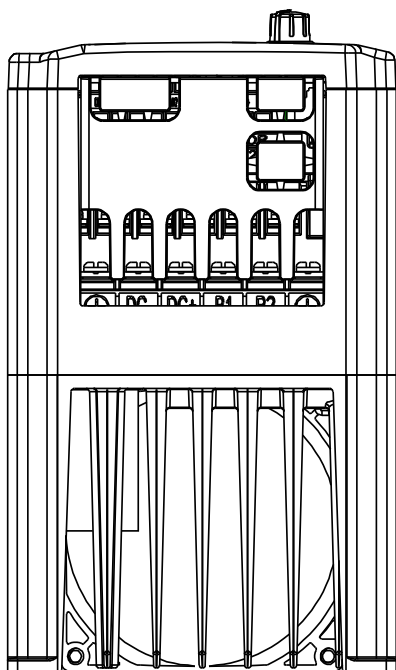
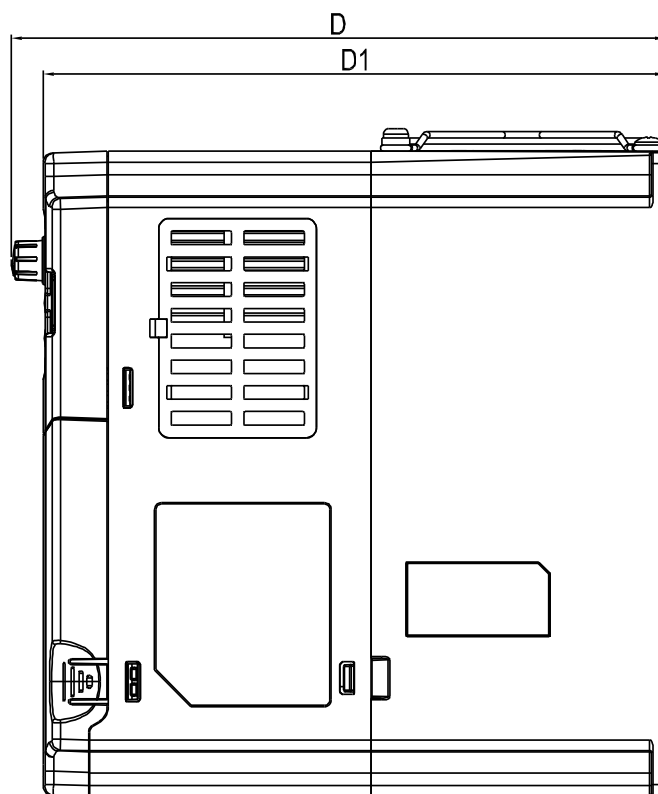
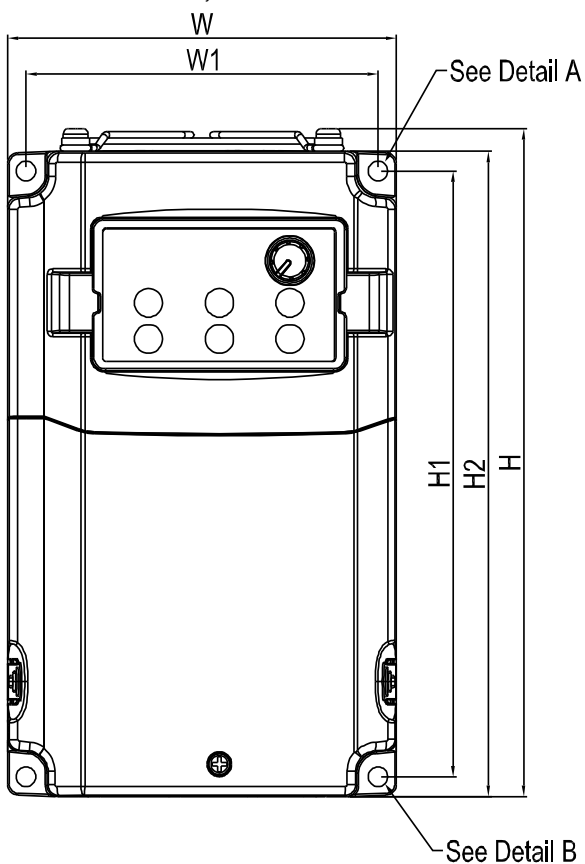

Detail A (Mounting Hole)

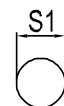

Detail B (Mounting Hole)

Unit: mm [inch]

Frame	W	W1	H	H1	H2	D	D1	S1	Φ1	Φ2
A0	110.0 [4.33]	99.6 [3.92]	186.3 [7.34]	169.0 [6.65]	180.0 [7.09]	185.0 [7.28]	176.0 [6.93]	5.5 [0.22]	-	-

Frame A

VFD040CB43A-20; VFD055CB43A-20; VFD075CB43A-20; VFD040CB43A-21;
 VFD055CB43A-21; VFD075CB43A-21

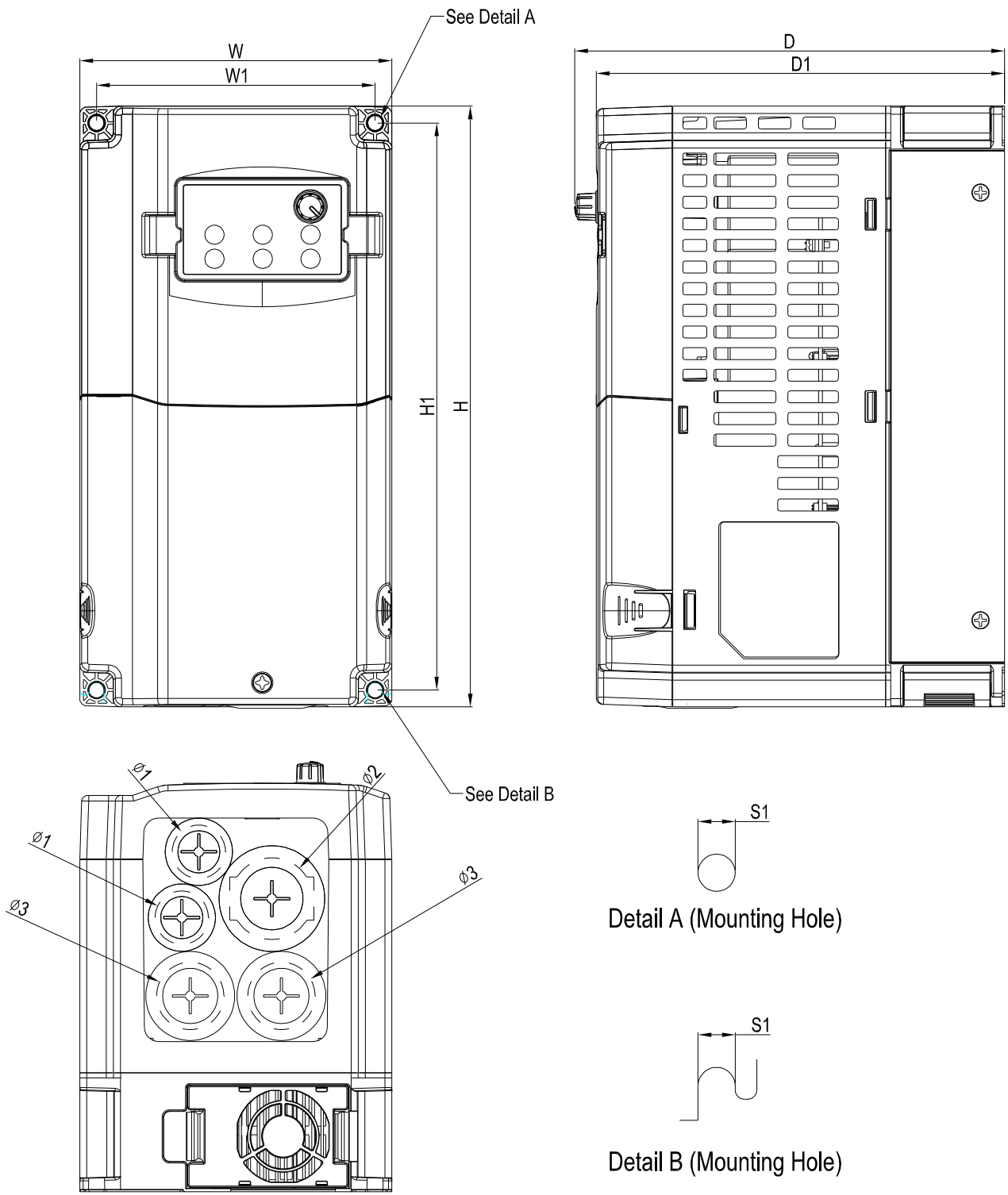

Unit: mm [inch]

Frame	W	W1	H	H1	D	D1	S1	φ1	φ2	φ3
A	130.0 [5.12]	116.0 [4.57]	250.0 [9.84]	236.0 [9.29]	179.0 [7.05]	170.0 [6.69]	6.2 [0.24]	22.2 [0.87]	34.0 [1.34]	28.0 [1.10]

Frame A

VFD040CB43A-21M; VFD055CB43A-21M; VFD075CB43A-21M

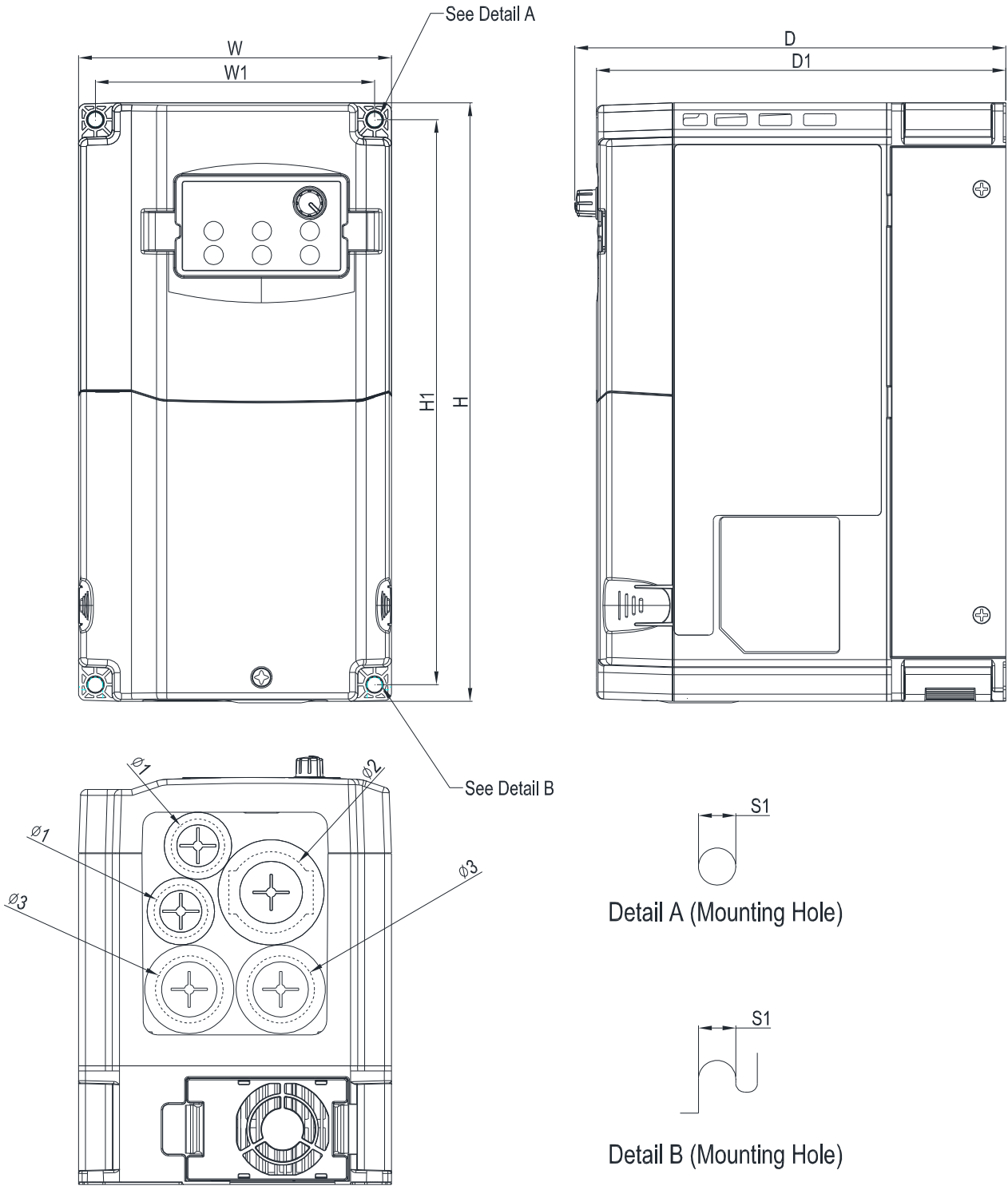

Unit: mm [inch]

Frame	W	W1	H	H1	D	D1	S1	$\phi 1$	$\phi 2$	$\phi 3$
A	130.0 [5.12]	116.0 [4.57]	250.0 [9.84]	236.0 [9.29]	179.0 [7.05]	170.0 [6.69]	6.2 [0.24]	22.2 [0.87]	34.0 [1.34]	28.0 [1.10]

Frame A (Fan enlarged)

VFD040CB43B-20; VFD055CB43B-20; VFD075CB43B-20

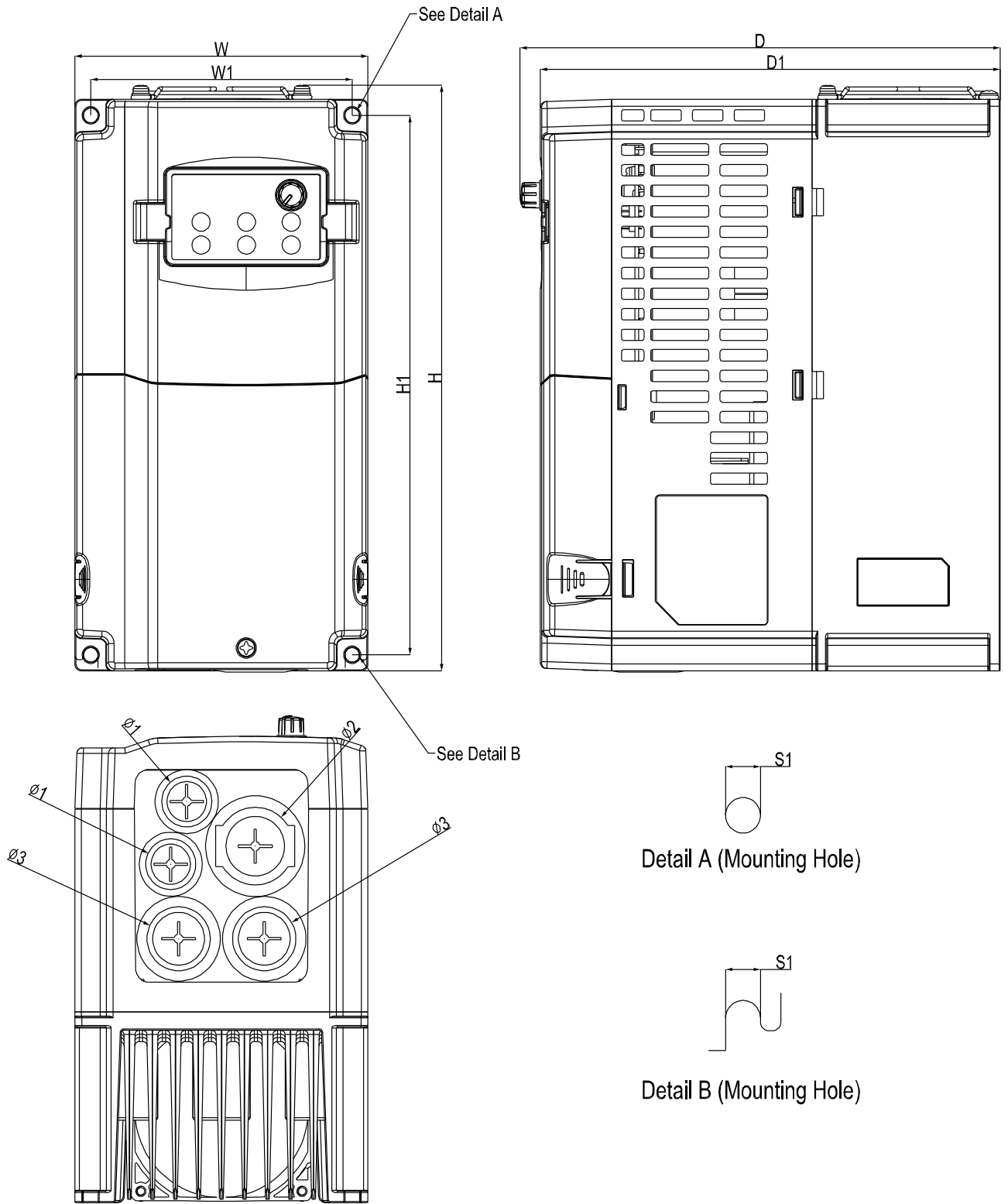

Unit: mm [inch]

Frame	W	W1	H	H1	D	D1	S1	$\Phi1$	$\Phi2$	$\Phi3$
A	130.0 [5.12]	116.0 [4.57]	250.0 [9.84]	236.0 [9.29]	213.0 [8.38]	204.0 [8.03]	6.2 [0.24]	22.2 [0.87]	34.0 [1.34]	28.0 [1.10]

Digital Keypad

KPE-LE02

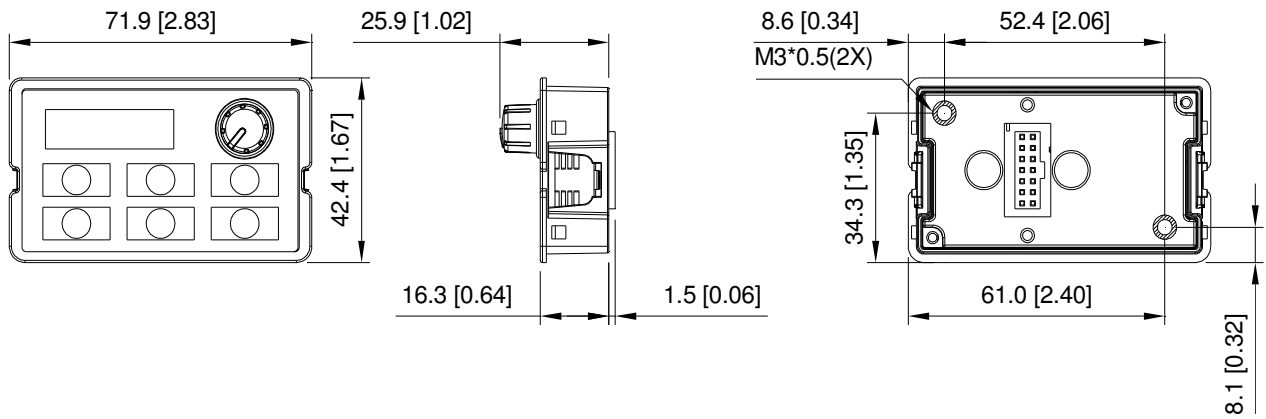

Chapter 2 Installation

Minimum Mounting Clearance and Installation

NOTE

- ☑ Prevent fiber particles, scraps of paper, shredded wood saw dust, metal particles, etc. from adhering to the heat sink
- ☑ Install the AC motor drive in a metal cabinet. When installing one drive below another one, use a metal separation between the AC motor drives to prevent mutual heating and to prevent the risk of fire accident.
- ☑ Install the AC motor drive in Pollution Degree 2 environments only: normally only nonconductive pollution occurs and temporary conductivity caused by condensation is expected.

The appearances shown in the following figures are for reference only.

Airflow direction:  (Blue arrow) inflow  (Red arrow) outflow

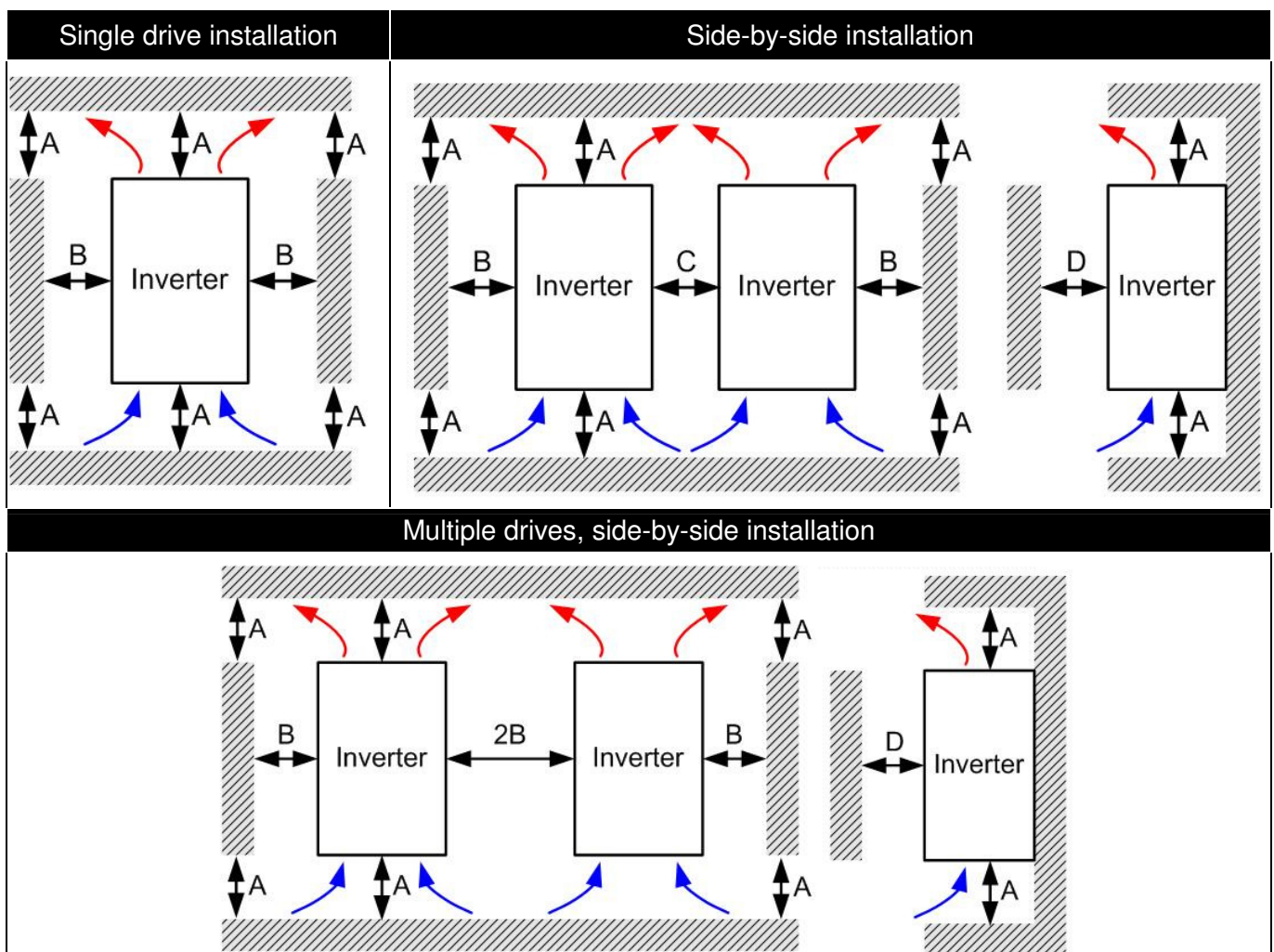

Multiple drives side-by-side installation and in rows

When installing one AC motor drive below another one (top-bottom installation), use a metal separation between the drives to prevent mutual heating. The temperature measured at the fan's inflow side must be lower than the temperature measured at the operation side. If the fan's inflow temperature is higher, use a thicker or larger size of metal separation. Operation temperature is the temperature measured at 50mm away from the fan's inflow side. (As shown in the figure below)

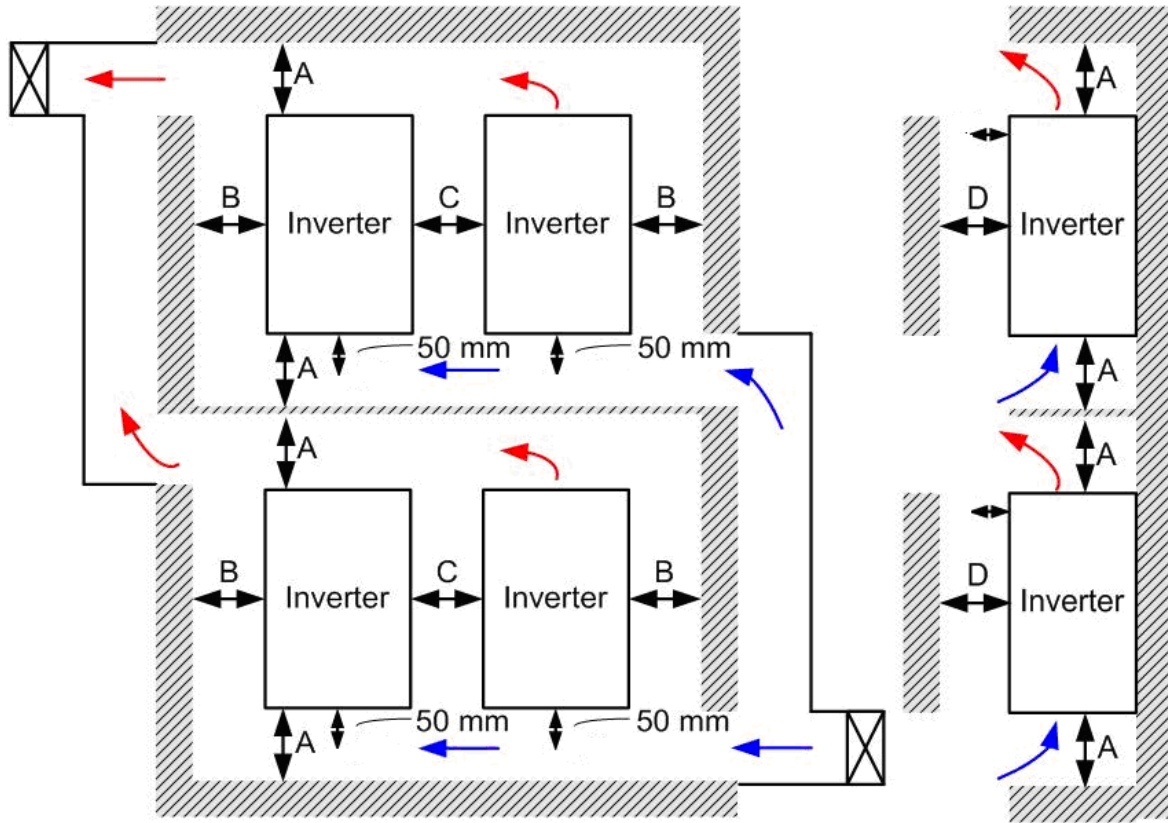

Minimum mounting clearance

Frame	A (mm)	B (mm)	C (mm)	D (mm)
A0-A	60	30	10	0

Frame A0	VFD004CB21A-20/-21/-21M; VFD007CB21A-20/-21/-21M; VFD004CB23A-20/-21/-21M; VFD007CB23A-20/-21/-21M; VFD015CB23A-20/-21/-21M; VFD007CB43A-20/-21/-21M; VFD015CB43A-20/-21/-21M; VFD015CB21A-20/-21/-21M; VFD022CB21A-20/-21/-21M; VFD022CB23A-20/-21/-21M; VFD037CB23A-20/-21/-21M; VFD022CB43A-20/-21/-21M; VFD037CB43A-20/-21/-21M; VFD022CB43B-20; VFD037CB43B-20
Frame A	VFD040CB43A-20/-21/-21M; VFD055CB43A-20/-21/-21M; VFD075CB43A-20/-21/-21M; VFD040CB43B-20; VFD055CB43B-20; VFD075CB43B-20

NOTE

- The minimum mounting clearances stated in the table above applies to AC motor drives frame A to D. A drive fails to follow the minimum mounting clearances may cause the fan to malfunction and heat dissipation problem.

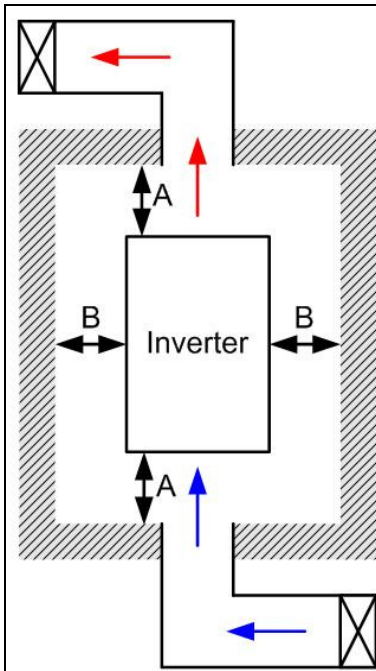
 **NOTE**

- ※ The mounting clearances stated in the figure is for installing the drive in an open area. To install the drive in a confined space (such as cabinet or electric box), please follow the following three rules: (1) Keep the minimum mounting clearances. (2) Install a ventilation equipment or an air conditioner to keep surrounding temperature lower than operation temperature. (3) Refer to parameter setting and set up Pr. 00-16, Pr.00-17, and Pr. 06-55.
- ※ The following table shows the heat dissipation and the required air volume when installing a single drive in a confined space. When installing multiple drives, the required air volume shall be multiplied by the number the drives.
- ※ Refer to the chart (Air flow rate for cooling) for ventilation equipment design and selection.
- ※ Refer to the chart (Power dissipation) for air conditioner design and selection.

Model No.	Air flow rate for cooling		Power dissipation of AC motor drive		
	Flow Rate (cfm)	Flow Rate (m ³ /hr)	Loss External (Heat sink)	Internal	Total
VFD004CB21A-20/-21/-21M	-	-	16	20	36
VFD007CB21A-20/-21/-21M	-	-	32	39	72
VFD015CB21A-20/-21/-21M	15	26	60	52	112
VFD022CB21A-20/-21/-21M	15	26	85	69	154
VFD004CB23A-20/-21/-21M	-	-	21	17	37
VFD007CB23A-20/-21/-21M	-	-	35	26	61
VFD015CB23A-20/-21/-21M	15	26	56	32	89
VFD022CB23A-20/-21/-21M	15	26	82	34	116
VFD037CB23A-20/-21/-21M	15	26	118	43	161
VFD007CB43A-20/-21/-21M	-	-	35	24	59
VFD015CB43A-20/-21/-21M	-	-	47	27	74
VFD022CB43A-20/-21/-21M	15	26	75	30	105
VFD037CB43A-20/-21/-21M	15	26	110	33	143
VFD040CB43A-20/-21/-21M	15	26	126	34	160
VFD055CB43A-20/-21/-21M	15	26	145	37	181
VFD075CB43A-20/-21/-21M	24	41	212	83	295
VFD022CB43B-20	49	83	75	33	108
VFD037CB43B-20	49	83	110	36	146
VFD040CB43B-20	46	78	126	37	163
VFD055CB43B-20	46	78	145	40	185
VFD075CB43B-20	46	78	212	84	296

- ※ The required airflow shown in chart is for installing single drive in a confined space.
- ※ When installing the multiple drives, the required air volume should be the required air volume for single drive X the number of the drives.

- ※ The heat dissipation shown in the chart is for installing single drive in a confined space.
- ※ When installing the multiple drives, volume of heat dissipation should be the heat dissipated for single drive X the number of the drives.
- ※ Heat dissipation for each model is calculated by rated voltage, current and default carrier.

Derating Curve Diagram of Normal Duty (Pr.00-16=0)

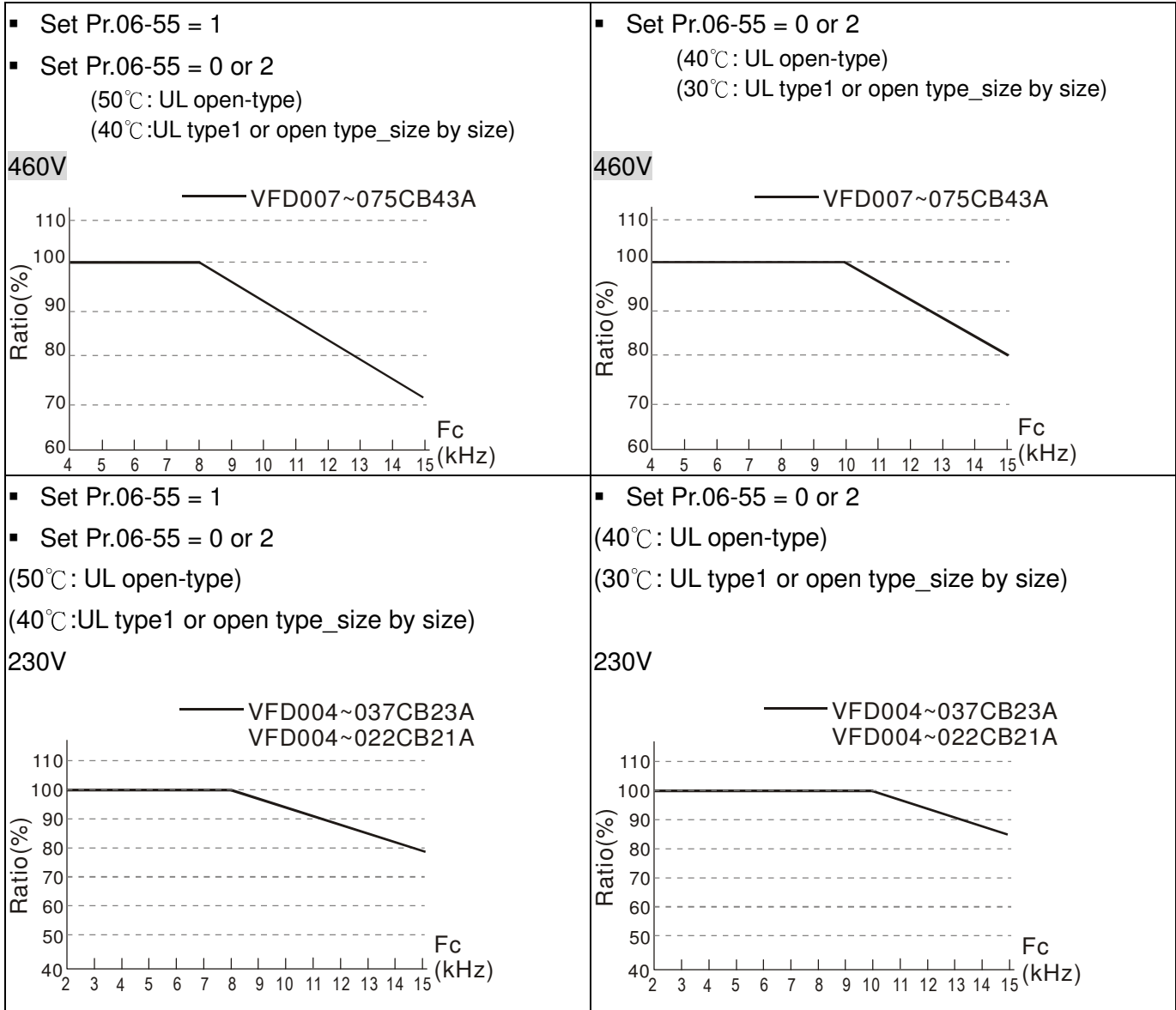

Derating Curve Diagram of Heavy Duty (Pr.00-16=1)

- Set Pr.06-55 = 1
- Set Pr.06-55 = 0 or 2
 (50°C: UL open-type)
 (40°C: UL type1 or open type_size by size)

460V

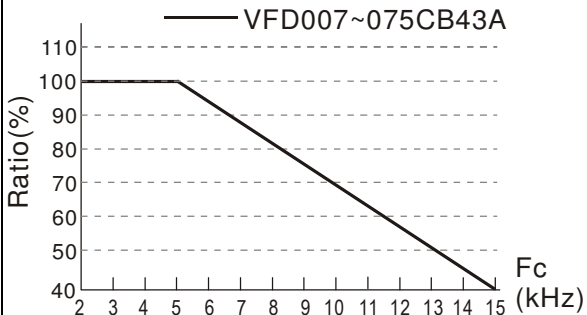

- Set Pr.06-55 = 1
- Set Pr.06-55 = 0 or 2
 (50°C: UL open-type)
 (40°C: UL type1 or open type_size by size)

230V

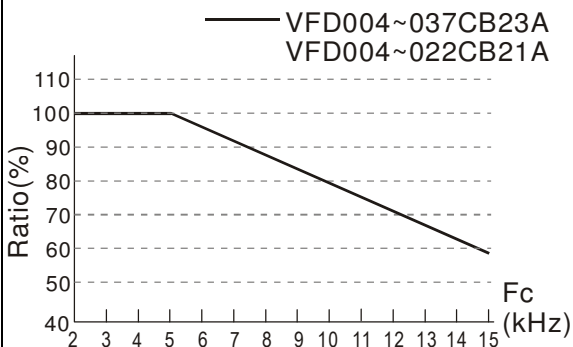

- Set Pr.06-55 = 0 or 2
 (40°C: UL open-type)
 (30°C: UL type1 or open type_size by size)

460V

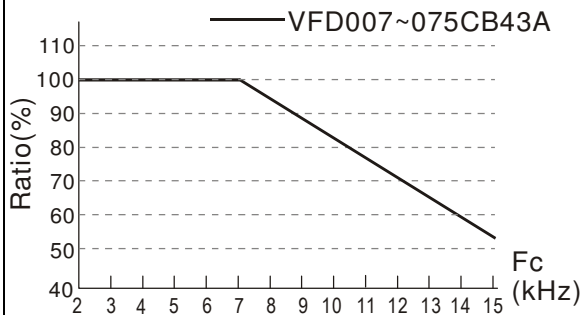

- Set Pr.06-55 = 0 or 2
 (40°C: UL open-type)
 (30°C: UL type1 or open type_size by size)

230V

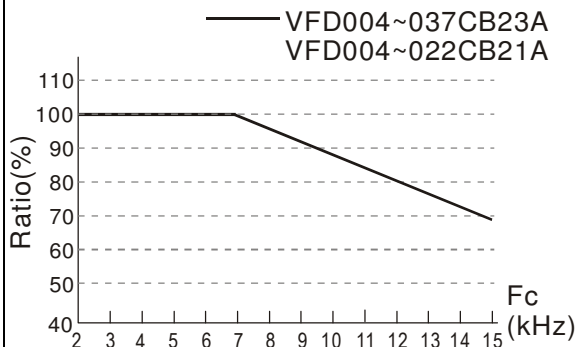

Chapter 3 Wiring

After removing the front cover, examine if the power and control terminals are clearly noted. Please read following precautions before wiring.

- ☑ Make sure that power is only applied to the R/L1, S/L2, T/L3 terminals. Failure to comply may result in damage to the equipments. The voltage and current should lie within the range as indicated on the nameplate (Chapter 1-1).
- ☑ All the units must be grounded directly to a common ground terminal to prevent lightning strike or electric shock.
- ☑ Please make sure to fasten the screw of the main circuit terminals to prevent sparks which is made by the loose screws due to vibration



- ☑ It is crucial to turn off the AC motor drive power before any wiring installation are made. A charge may still remain in the DC bus capacitors with hazardous voltages even if the power has been turned off therefore it is suggested for users to measure the remaining voltage before wiring. For your personnel saftery, please do not perform any wiring before the voltage drops to a safe level < 25 Vdc. Wiring installation with remaninig voltage condition may caus sparks and short circuit.
- ☑ Only qualified personnel familiar with AC motor drives is allowed to perform installation, wiring and commissioning. Make sure the power is turned off before wiring to prevent electric shock.



- ☑ When wiring, please choose the wires with specification that complys with local regulation for your personnel safety.
- ☑ Check following items after finishing the wiring:
 1. Are all connections correct?
 2. Any loosen wires?
 3. Any short-circuits between the terminals or to ground?

Wiring Diagram

* It provides 1-phase/3-phase power

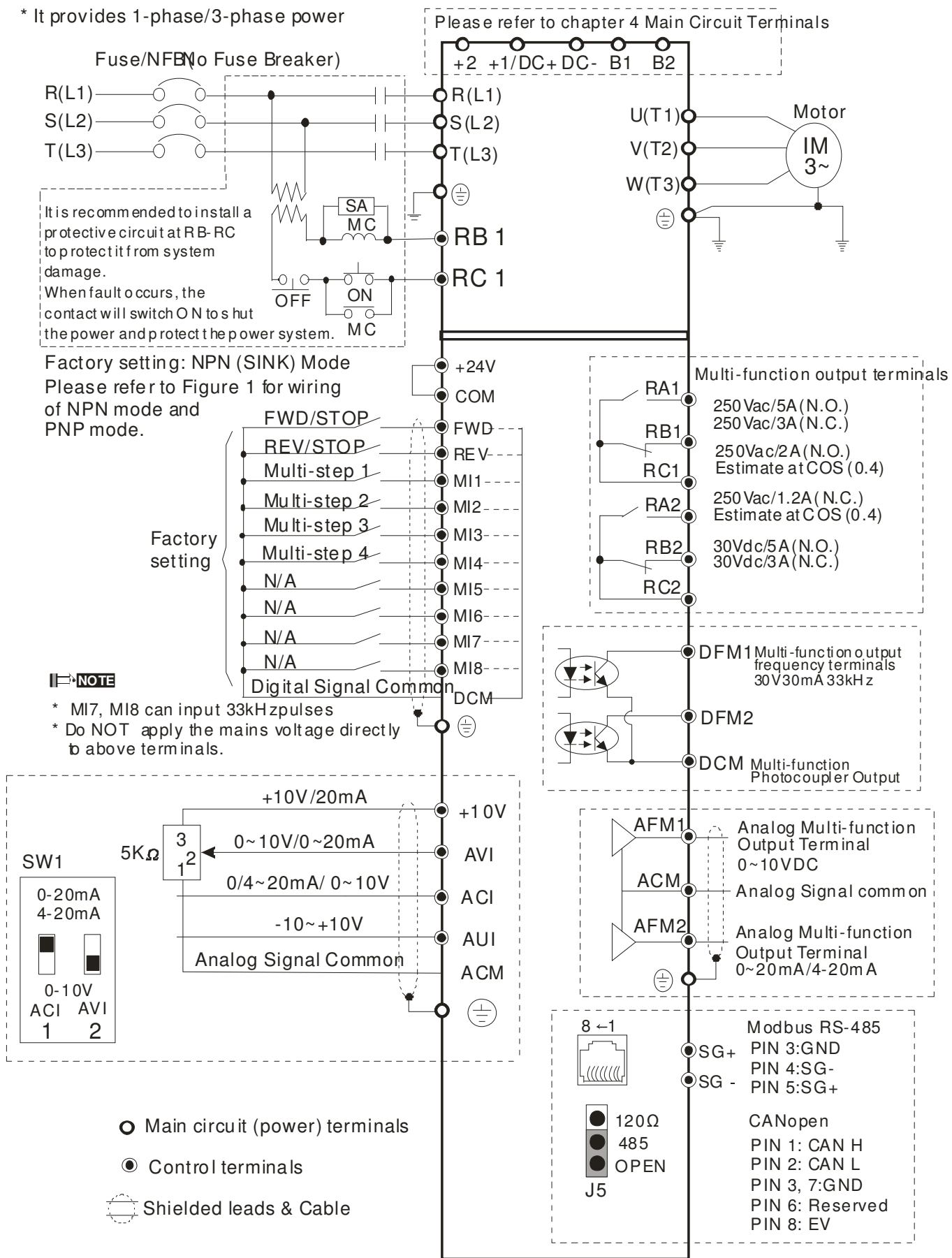
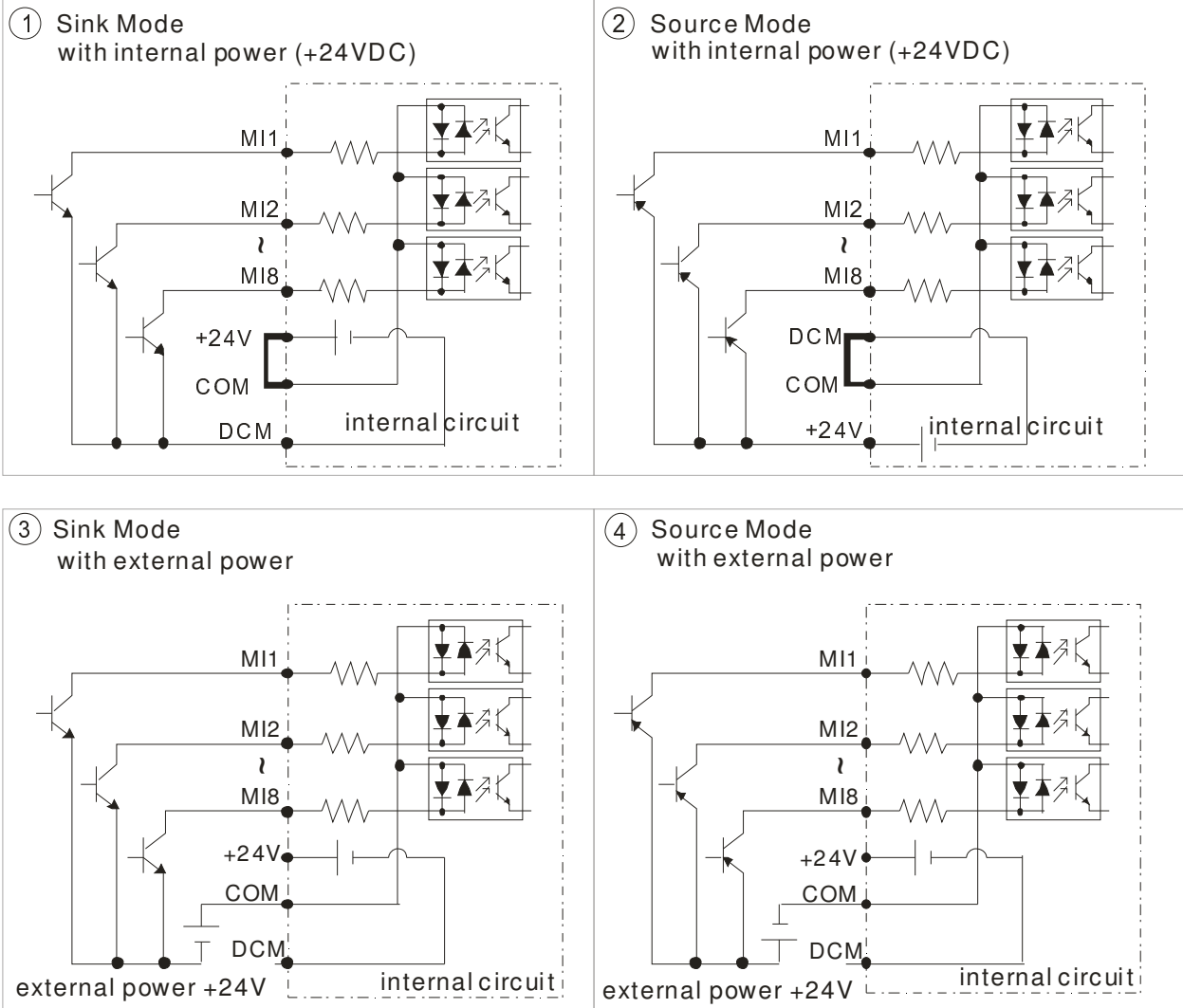
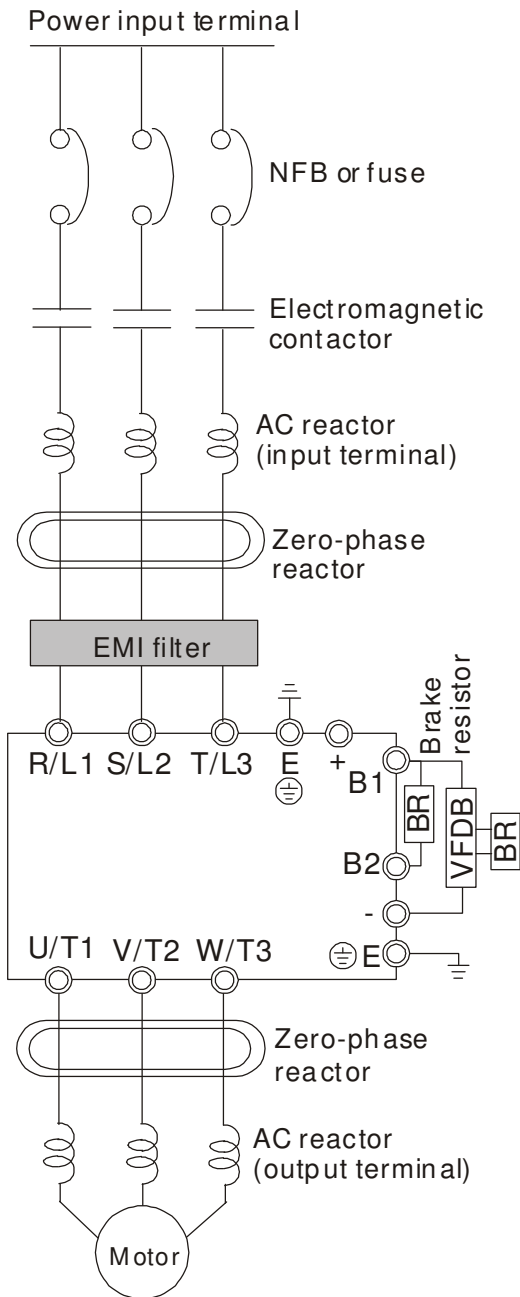

Figure 1

SINK (NPN) /SOURCE (PNP) Mode





Power input terminal	Please supply power according to the rated power specifications indicated in the manual. (Refer to Chapter 7)
NFB or Fuse	There may be a large inrush current during power on. Refer to Chapter 6-2 NFB to select a suitable NFB or fuse.
Electromagnetic contactor	Switching ON/OFF the primary side of the electromagnetic contactor can turn the integrated elevator device ON.OFF, but frequency switching is a cause of machine failure. Do not switch ON/OFF more than once an hour. Do not use the electromagnetic contactor as the power switch for the integrated elevator drive; doing so will shorten the life of the integrated elevator drive.
AC reactor (input terminal)	When the main power supply capacity is greater than 500kVA, or when it switches into the phase capacitor, the instantaneous peak voltage and current generated will destroy the internal circuit of the integrated elevator drive. It is recommended to install an input side AC reactor in the integrated elevator drive. This will also improve the power factor and reduce power harmonics. The wiring distance should be within 10m. Please refer to Chapter 6-4
Zero-phase reactor	Used to reduce radiated interference, especially in environments with audio devices, and reduce input and output side interference. The effective range is AM band to 10MHz.Please refer to Chapter 6-5
EMI filter	Can be used to reduce electromagnetic interference.
Brake resistor and Brake module	Use to shorten deceleration time of the motor. Please refer to Chapter 6-1
AC reactor (output terminal)	The wiring length of the motor will affect the size of the reflected wave on the motor end. It is recommended to install an AC reactor when the motor wiring length is greater than 20 meters. Refer to Chapter 6-4

Chapter 4 Main Circuit Terminals

Main Circuit Diagram

For frame A0

* Provide 1-phase/3-phase input power

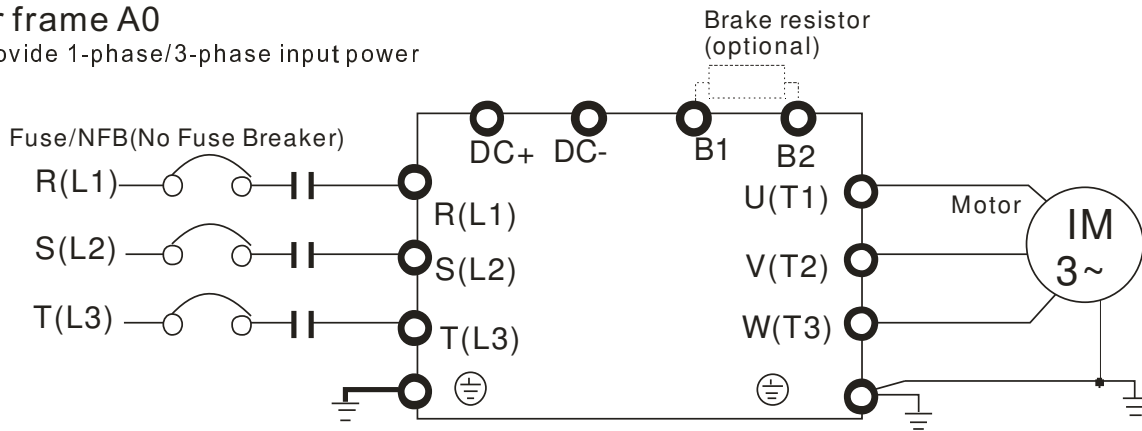

Terminals	Descriptions
R/L1, S/L2, T/L3	AC line input terminals 3-phase; AC line input terminals 1-phase (R/L1, S/L2);
U/T1, V/T2, W/T3	AC drive output terminals for connecting 3-phase induction motor
DC+, DC-	Connections for brake unit (VFDB series)
B1, B2	Connections for brake resistor (optional)
⊕	Earth connection, please comply with local regulations.

For frame A

* Provide 3-phase input power

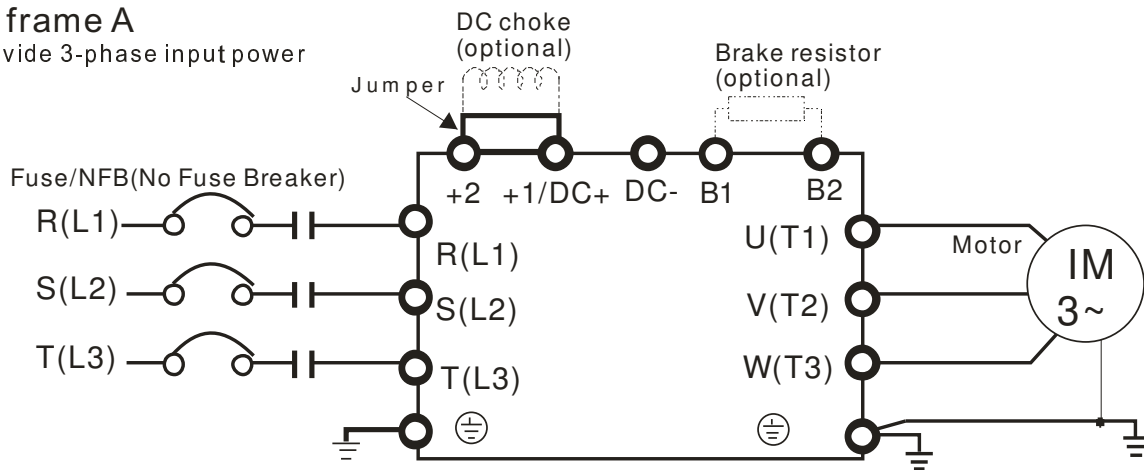

Terminals	Descriptions
R/L1, S/L2, T/L3	AC line input terminals 3-phase
U/T1, V/T2, W/T3	AC drive output terminals for connecting 3-phase induction motor
+1, +2	Connections for DC reactor to improve the power factor. It needs to remove the jumper for installation.
+1/DC+, -/DC-	Connections for brake unit (VFDB series)
B1, B2	Connections for brake resistor (built-in)
⊕	Earth connection, please comply with local regulations.



Main power terminals

- ☑ Do not connect 3-phase model to one-phase power. R/L1, S/L2 and T/L3 has no phase-sequence requirement, it can be used upon random selection.
- ☑ It is recommend to add a magnetic contactor (MC) to the power input wiring to cut off power quickly and reduce malfunction when activating the protection function of the AC motor drive. Both ends of the MC should have an R-C surge absorber.
- ☑ Fasten the screws in the main circuit terminal to prevent sparks condition made by the loose screws due to vibration.
- ☑ Please use voltage and current within the specification.
- ☑ When using a general GFCI (Ground Fault Circuit Interrupter), select a current sensor with sensitivity of 200mA or above and not less than 0.1-second operation time to avoid nuisance tripping.
- ☑ Please use the shield wire or tube for the power wiring and ground the two ends of the shield wire or tube.
- ☑ Do NOT run/stop AC motor drives by turning the power ON/OFF. Run/stop AC motor drives by RUN/STOP command via control terminals or keypad. If you still need to run/stop AC motor drives by turning power ON/OFF, it is recommended to do so only ONCE per hour.

Output terminals for main circuit

- ☑ When it needs to install the filter at the output side of terminals U/T1, V/T2, W/T3 on the AC motor drive. Please use inductance filter. Do not use phase-compensation capacitors or L-C (Inductance-Capacitance) or R-C (Resistance-Capacitance), unless approved by Delta.
- ☑ DO NOT connect phase-compensation capacitors or surge absorbers at the output terminals of AC motor drives.
- ☑ Use well-insulated motor, suitable for inverter operation.

Terminals for connecting DC reactor, external brake resistor, external brake resistor and DC circuit

- ☑ This is the terminals used to connect the DC reactor to improve the power factor. For the factory setting, it connects the short-circuit object. Please remove this short-circuit object before connecting to the DC reactor.

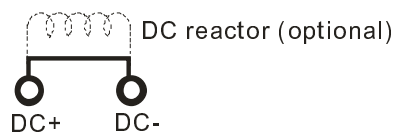

- ☑ When the AC Motor Drive is connected directly to a large-capacity power transformer (600kVA or above) or when a phase lead capacitor is switched, excess peak currents may occur in the power input circuit due to the load changes and the converter section may be damaged. To

avoid this, it is recommend to use a serial connected AC input reactor(6%) at the AC Motor Drive mains input side to reduce the current and improve the input power efficiency.

- ☑ Connect a brake resistor or brake unit in applications with frequent deceleration ramps, short deceleration time, too low brake torque or requiring increased brake torque.

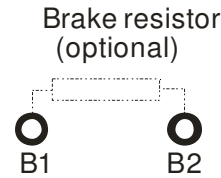

- ☑ The external brake resistor should connect to the terminals (B1, B2) of AC motor drives.
- ☑ For those models without built-in brake resistor, please connect external brake unit and brake resistor (both of them are optional) to increase brake torque.
- ☑ DC+ and DC- are connected by common DC bus, please refer to Chapter 5-1(Main Circuit Terminal) for the wiring terminal specification and the wire gauge information.
- ☑ Please refer to the VFDB manual for more information on wire gauge when installing the brake unit.

Frame A0

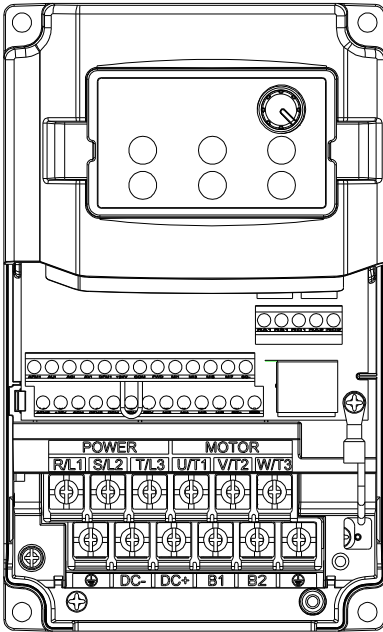

Main circuit terminals:

R/L1, S/L2, T/L3, U/T1, V/T2, W/T3, ⊕, DC+, DC-, B1, B2

Models	Max. Wire Gauge	Min. Wire Gauge	Torque
VFD004CB21A-20/-21/-21M	8 AWG (8.4mm ²)	14 AWG (2.1mm ²)	M4 20kg-cm (17.4 lb-in.) (1.96Nm)
VFD007CB21A-20/-21/-21M		12 AWG (3.3mm ²)	
VFD015CB21A-20/-21/-21M		10 AWG (5.3mm ²)	
VFD022CB21A-20/-21/-21M		8 AWG (8.4mm ²)	
VFD004CB23A-20/-21/-21M		14 AWG (2.1mm ²)	
VFD007CB23A-20/-21/-21M		14 AWG (2.1mm ²)	
VFD015CB23A-20/-21/-21M		12 AWG (3.3mm ²)	
VFD022CB23A-20/-21/-21M		10 AWG (5.3mm ²)	
VFD037CB23A-20/-21/-21M		8 AWG (8.4mm ²)	
VFD007CB43A-20/-21/-21M		14 AWG (2.1mm ²)	
VFD015CB43A-20/-21/-21M		14 AWG (2.1mm ²)	
VFD022CB43A-20/-21/-21M		14 AWG (2.1mm ²)	
VFD022CB43B-20		14 AWG (2.1mm ²)	
VFD037CB43A-20/-21/-21M		10 AWG (5.3mm ²)	
VFD037CB43B-20	10 AWG (5.3mm ²)		

UL installations must use 600V, 75°C or 90°C wire. Use copper wire only.

NOTE

Figure 1 shows the terminal specification.

Figure 2 shows the specification of insulated heat shrink tubing that comply with UL (600V, YDPU2).

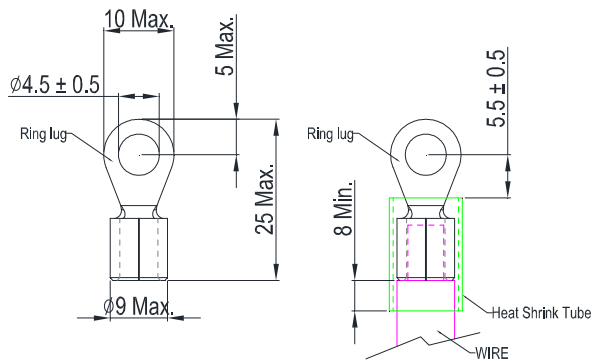

Figure 1

Figure 2

Frame A

Main circuit terminals :

R/L1, S/L2, T/L3, U/T1, V/T2, W/T3, \oplus , DC+(+2,+1), DC-, B1, B2

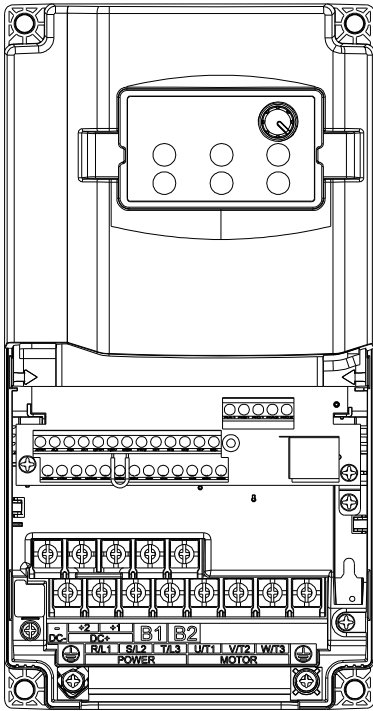

Models	Max. Wire Gauge	Min. Wire Gauge	Torque
VFD040CB43A-20/-21/-21M VFD040CB43B-20	8 AWG (8.4mm ²)	10 AWG (5.3mm ²)	M4 20kg-cm (17.4 lb-in.) (1.96Nm)
VFD055CB43A-20/-21/-21M VFD055CB43B-20		10 AWG (5.3mm ²)	
VFD075CB43A-20/-21/-21M VFD075CB43B-20		8 AWG (8.4mm ²)	

UL installations must use 600V, 75°C or 90°C wire. Use copper wire only.

NOTE

Figure 1 shows the terminal specification.

Figure 2 shows the specification of insulated heat shrink tubing that comply with UL (600V, YDPU2).

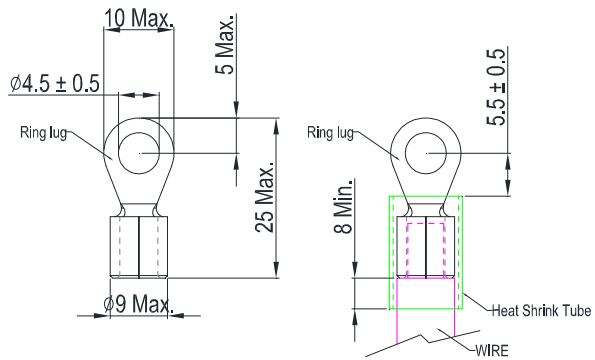

Figure 1

Figure 2

Chapter 5 Control Terminals

Please remove the top cover before wiring the multi-function input and output terminals,

The drive appearances shown in the figures are for reference only, a real drive may look different.

Remove the cover for wiring

Frame A0 & A

Screw torque:

Frame A0: 6~8Kg-cm [5.21~6.94lb-in.]

Frame A: 10~12Kg-cm [8.68~10.4lb-in.]

Loosen the screws and press the tabs on both sides to remove the cover.

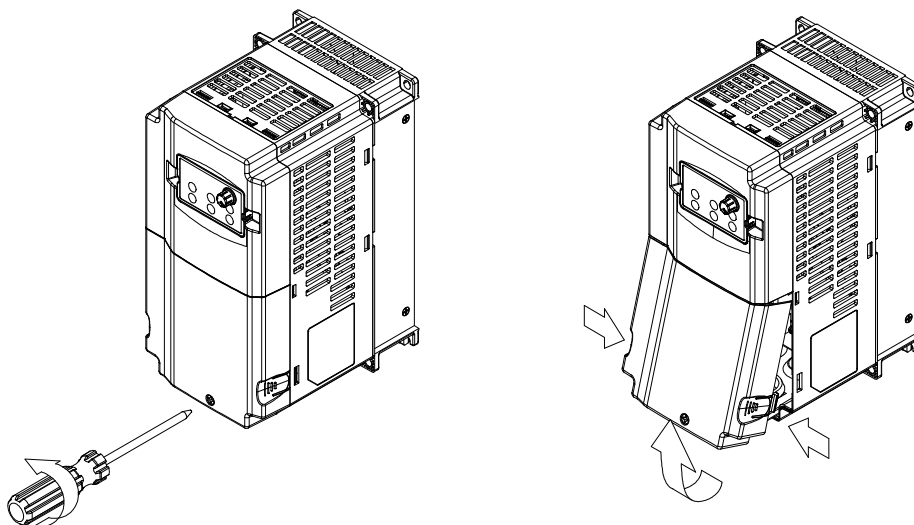

Control Terminal the sketch map

Frame A0

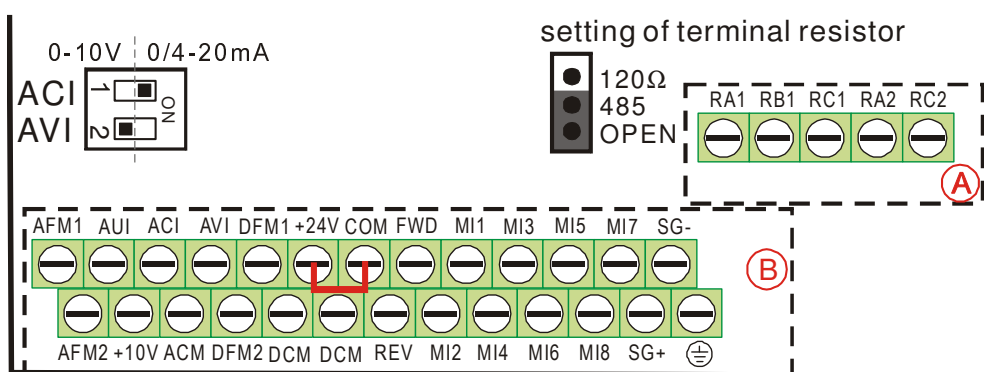

Frame A

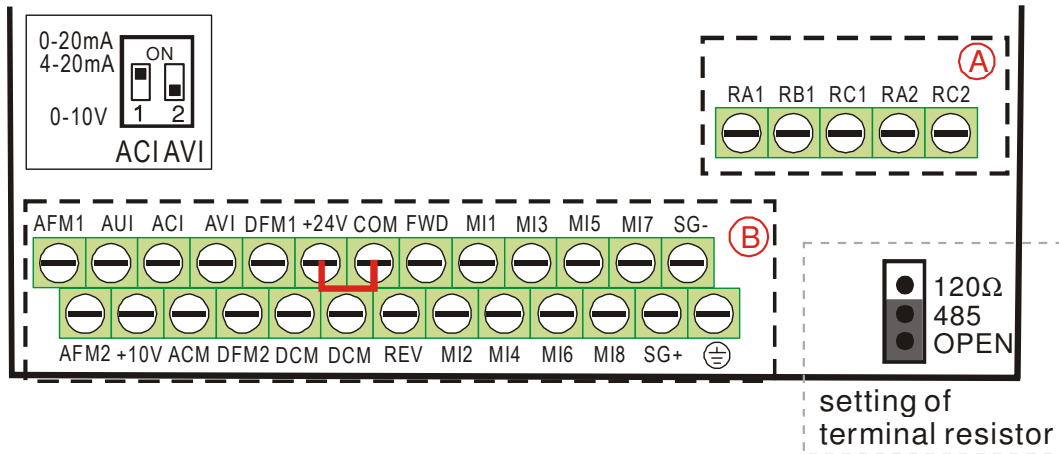

Specifications of Control Terminal

Wire Gauge: 26~16AWG (0.1281-1.318mm²) ,



Torque: (A) 5kg-cm [4.31lb-in.] (0.49Nm) (As shown in figure above)

(B) 8kg-cm [6.94lb-in.] (0.78Nm) (As shown in figure above)

Wiring precautions:

- Reserves 5mm and properly install the wire into the terminal; fasten the installation by a slotted screwdriver. If the wire is stripped, sort the wire before install into the terminal.
- Flathead screwdriver: blade width 3.5mm, tip thickness 0.6mm
- In the figure above, the factory setting for S1-SCM is short circuit. The factory setting for +24V-COM is short circuit and SINK mode (NPN); please refer to Chapter 3 Wiring for more detail.

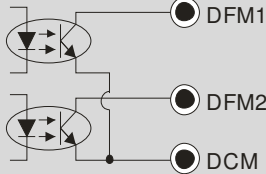
Terminals	Terminal Function	Factory Setting (NPN mode)
+24V	Digital control signal common (Source)	+24V±5% 100mA
COM	Digital control signal common (Sink)	Common for multi-function input terminals
FWD	Forward-Stop command	FWD-DCM: ON→ forward running OFF→ deceleration to stop
REV	Reverse-Stop command	REV-DCM: ON→ reverse running OFF→ deceleration to stop
MI1 ~ MI6	Multi-function input 1~6	Refer to parameters 02-01~02-08 to program the multi-function inputs MI1~MI8. ON: the activation current is 6.5mA ≥ 11Vdc OFF: leakage current tolerance is 10μA ≤ 11Vdc
MI7 ~ MI8	Multi-function input 7~8	It can be a multi input option for Pr02-01 ~ 02-08. It can also be used as a PG function. For more information on PG function, see page 6-5.
RA1	Multi-function relay output 1 (N.O.) a	Resistive Load: 5A(N.O.)/3A(N.C.) 250VAC
RB1	Multi-function relay output 1 (N.C.) b	5A(N.O.)/3A(N.C.) 30VDC

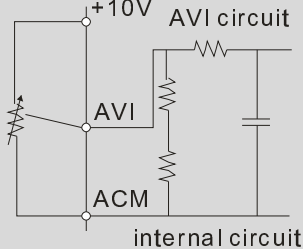
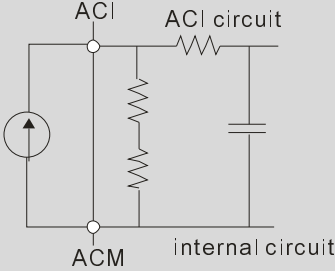
Terminals	Terminal Function	Factory Setting (NPN mode)
RC1	Multi-function relay common 1	Inductive Load (COS 0.4): 2.0A(N.O.)/1.2A(N.C.) 250VAC
RA2	Multi-function relay output 2 (N.O.) a	2.0A(N.O.)/1.2A(N.C.) 30VDC
RC2	Multi-function relay common 2	It is used to output each monitor signal, such as drive is in operation, frequency attained or overload indication.
DFM1	Digital frequency meter 1 (when Pr.02-21=0, DFM1 is the setting of Pr.02-16) (When Pr.02-21 ≥ 1, DM1 is the pulse output.)	The AC motor drive releases various monitor signals, such as drive in operation, frequency attained and overload indication, via transistor (open collector). Regard the pulse voltage as the output monitor signal Duty-cycle: 50%
DFM2	Digital frequency meter 2 (When Pr.02-55 = 0, DFM2 is the setting value of Pr.02-17.) (When Pr.02-55 ≥ 1, DFM2 is the pulse output)	Min. load impedance: 1kΩ/100pf Max. current: 30mA Max. voltage: 30Vdc
DCM	Digital frequency signal common	
SG+	Modbus RS-485	PIN4 · PIN5 equals to the PIN4, PIN5 of the RJ45 internet cable connector. PIN 3: GND PIN 4: SG- PIN 5: SG+
SG-		
+10V	Potentiometer power supply	Analog frequency setting: +10Vdc 20mA
AVI	Analog voltage input 	Impedance: 20kΩ Range: 0~10V/0~20mA/ 4~20mA(Pr.03-38) =0~Max. Output Frequency (Pr.01-00) AVI switch, factory setting is 0~10V
ACI	Analog current input 	Impedance: 500Ω Range: 4~20mA/0~10V/0~20mA(Pr.03-39) =0~Max. Output Frequency (Pr.01-00) ACI Switch, factory setting is 4~20mA

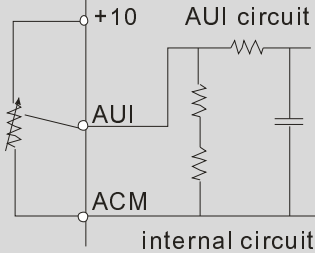
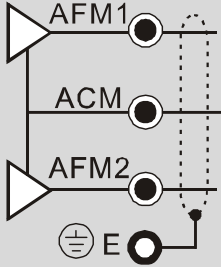
Terminals	Terminal Function	Factory Setting (NPN mode)
AUI	Auxiliary analog voltage input 	Impedance: 20kΩ Range: -10~+10VDC=0 ~ Max. Output Frequency(Pr.01-00)
AFM1		Impedance: 100kΩ (voltage output) Output current: 2mA max Resolution: 0~10V corresponds to Max. operation frequency Range: 0~10V
AFM2		Impedance: 100Ω (current output) Output current: 20mA max Resolution: 0~20mA corresponds to Max. operation frequency Range: 0~20mA, 4~20mA
ACM	Analog Signal Common	Common for analog terminals

NOTE: Wire size of analog control signals: 18 AWG (0.75 mm²) with shielded wire

Analog input terminals (AVI, ACI, AUI, ACM)

- ☑ Analog input signals are easily affected by external noise. Use shielded wiring and keep it as short as possible (<20m) with proper grounding. If the noise is inductive, connecting the shield to terminal ACM can bring improvement.
- ☑ If the analog input signals are affected by noise from the AC motor drive, please connect a capacitor and ferrite core as indicated in the following diagram.

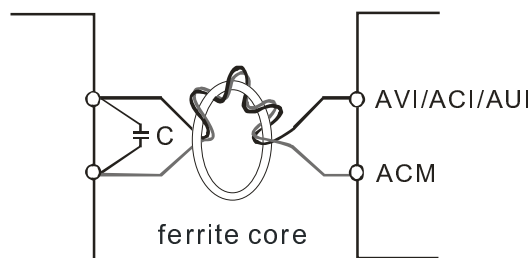

Wind each wires 3 times or more around the core

Digital inputs (FWD, REV, MI1~MI8, COM)

- ☑ When using contacts or switches to control the digital inputs, please use high quality components to avoid contact bounce.

Transistor outputs (MO1, MO2, MCM)

- ☑ Make sure to connect the digital outputs to the right polarity.
- ☑ When connecting a relay to the digital outputs, connect a surge absorber across the coil and check the polarity.

PG Function Explanation

1. When C200 is running at speed mode, it uses external terminal MI7~MI8 as PG connection function terminal.
2. C200 uses encoder, open collector of only 24Vdc. The maximum cable length of encoder is 30m. For example: Delta's encoder (ES3-06CN6941).
3. For External terminal MI7~MI8, their the minimum working voltage is 21Vdc, maximum input/output frequency is 33kHz. Refer to the formula below:

$$\text{Maximum output rotation speed (rpm)} / 60 * \text{PG} \leq 33.000\text{Hz}$$

$$\text{Maximum output rotation speed (rpm)} = (120 * \text{frequency} / \text{motor pole number})$$

For example: Set up PG function to be 600pulse, pole number to be 4 and the maximum rotation frequency is 60Hz.

$$\text{The maximum rotation speed (rpm)} = (120 * 60) / 4 = 1800\text{rpm}$$

$$1800 / 60 * 600 = 1800\text{Hz}$$

4. Set up Pr10-01~ 10-04 before using PG function. Its wiring diagram is shown as below:

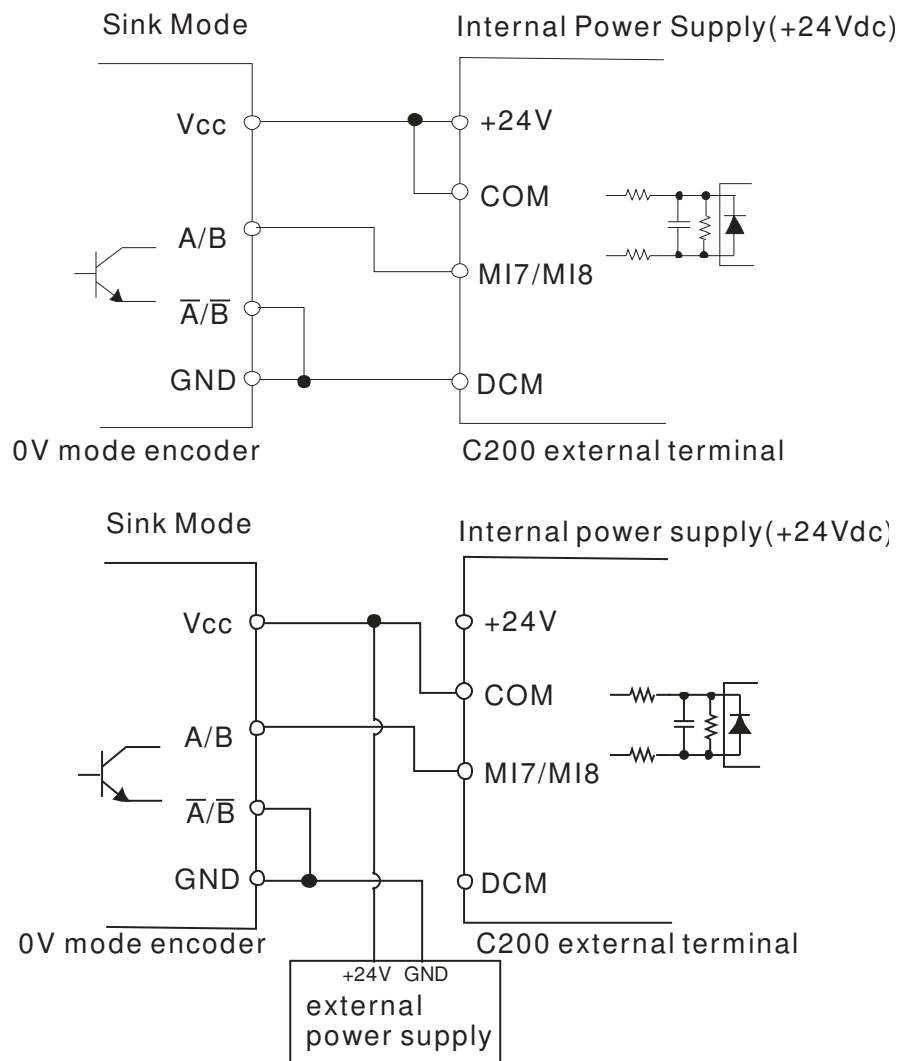

5. Since MI1~MI8 shares the same COM, therefore when using a PG card, MI~MI6 can only be applied at SINK MODE.

Chapter 6 Optional Accessories

The optional accessories listed in this chapter are available upon request. Installing additional accessories to your drive would substantially improve the drive's performance. Please select an applicable accessory according to your need or contact the local distributor for suggestion.

6-1 All Brake Resistors and Brake Units Used in AC Motor Drives

230V 1-phase

Applicable Motor		* ¹ 125%Braking Torque 10%ED				* ² Max. Brake Torque		
HP	kW	Braking Torque (kg-m)	* ³ Braking Resistor series for each Brake Unit	Resistor value spec. for each AC motor Drive	Total Braking Current (A)	Min. Resistor Value (Ω)	Max. Total Braking Current (A)	Peak Power (kW)
0.5	0.4	0.27	BR080W200*1	80W200Ω	1.9	63.3	6	2.3
1	0.75	0.51	BR080W200*1	80W200Ω	1.9	63.3	6	2.3
2	1.5	1.0	BR200W091*1	200W91Ω	4.2	47.5	8	3.0
3	2.2	1.5	BR300W070*1	300W70Ω	5.4	38.0	10	3.8

230V 3-phase

Applicable Motor		* ¹ 125%Braking Torque 10%ED				* ² Max. Brake Torque		
HP	kW	Braking Torque (kg-m)	* ³ Braking Resistor series for each Brake Unit	Resistor value spec. for each AC motor Drive	Total Braking Current (A)	Min. Resistor Value (Ω)	Max. Total Braking Current (A)	Peak Power (kW)
0.5	0.4	0.27	BR080W200*1	80W200Ω	1.9	63.3	6	2.3
1	0.75	0.51	BR080W200*1	80W200Ω	1.9	63.3	6	2.3
2	1.5	1.0	BR200W091*1	200W91Ω	4.2	47.5	8	3.0
3	2.2	1.5	BR300W070*1	300W70Ω	5.4	38.0	10	3.8
5	3.7	2.5	BR400W040*1	400W40Ω	9.5	19.0	20	7.6

460V

Applicable Motor		* ¹ 125%Braking Torque 10%ED				* ² Max. Brake Torque		
HP	kW	Braking Torque (kg-m)	* ³ Braking Resistor series for each Brake Unit	Resistor value spec. for each AC motor Drive	Total Braking Current (A)	Min. Resistor Value (Ω)	Max. Total Braking Current (A)	Peak Power (kW)
1	0.75	0.5	BR080W750*1	80W750Ω	1	190.0	4	3.0
2	1.5	1.0	BR200W360*1	200W360Ω	2.1	126.7	6	4.6
3	2.2	1.5	BR300W250*1	300W250Ω	3	108.6	7	5.3
5	3.7	2.5	BR400W150*1	400W150Ω	5.1	84.4	9	6.8
5.5	4.0	2.7	BR1K0W075*1	1000W75Ω	10.2	54.3	14	10.6
7.5	5.5	3.7	BR1K0W075*1	1000W75Ω	10.2	54.3	14	10.6
10	7.5	5.1	BR1K0W075*1	1000W75Ω	10.2	47.5	16	12.2

*¹ Calculation for 125% brake torque: $(kW) \times 125\% \times 0.8$; where 0.8 is motor efficiency.

Because there is a resistor limit of power consumption, the longest operation time for 10%ED is 10sec (on: 10sec/ off: 90sec).

*² Please refer to the Brake Performance Curve for "Operation Duration & ED" vs. "Braking Current".

*³ For heat dissipation, a resistor of 400W or lower should be fixed to the frame and maintain the surface temperature below 50°C; a resistor of 1000W and above should maintain the surface temperature below 350°C.



NOTE

1. Definition for Brake Usage ED%

Explanation: The definition of the brake usage ED (%) is for assurance of enough time for the brake unit and brake resistor to dissipate away heat generated by braking. When the brake resistor heats

up, the resistance would increase with temperature, and brake torque would decrease accordingly. Recommended cycle time is one minute.

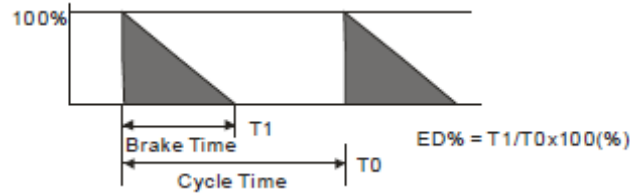

For safety concern, install an overload relay (O.L) between the brake unit and the brake resistor in conjunction with the magnetic contactor (MC) prior to the drive for abnormal protection. The purpose of installing the thermal overload relay is to protect the brake resistor from damage due to frequent brake, or due to brake unit keeping operating resulted from unusual high input voltage. Under such circumstance, just turn off the power to prevent damaging the brake resistor.

2. If damage to the drive or other equipment is due to the fact that the brake resistors and brake modules in use are not provided by Delta, the warranty will be void.
3. Take into consideration the safety of the environment when installing the brake resistors. If the minimum resistance value is to be utilized, consult local dealers for the calculation of Watt figures.
4. This chart is for normal usage; if the AC motor drive is applied for frequent braking, it is suggested to enlarge 2~3 times of the Watts.
5. Thermal Relay:

Thermal relay selection is basing on its overload capability. A standard braking capacity for C2000 is 10%ED (Tripping time=10s). The figure below is an example of 406V, 110kw AC motor drive. It requires the thermal relay to take 260% overload capacity in 10s (Host starting) and the braking current is 126A. In this case, user should select a rated 50A thermal relay. The property of each thermal relay may vary among different manufacturer, please carefully read specification.

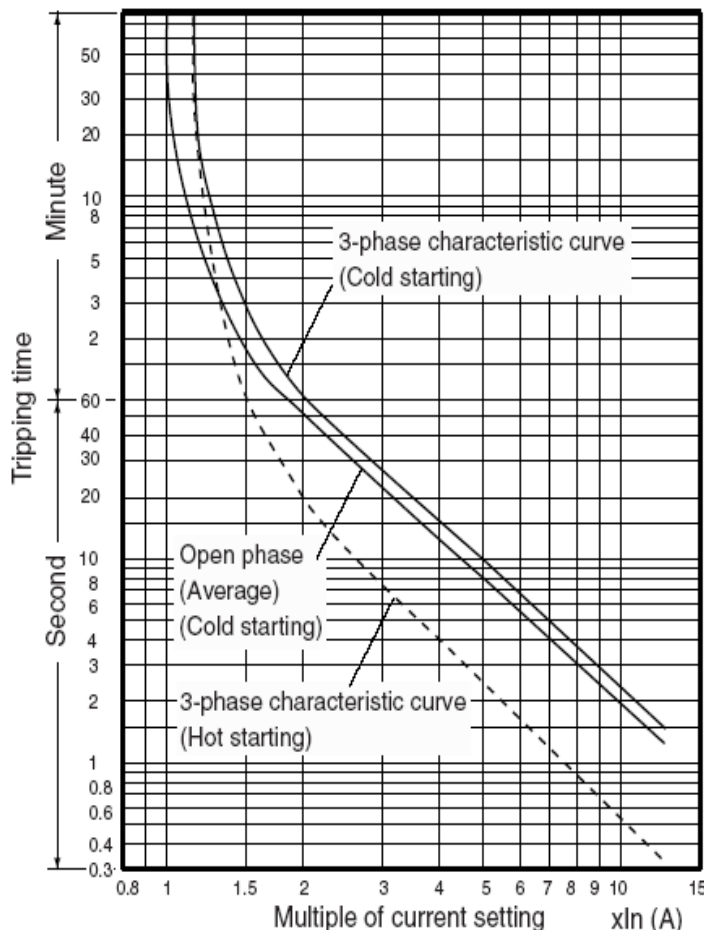

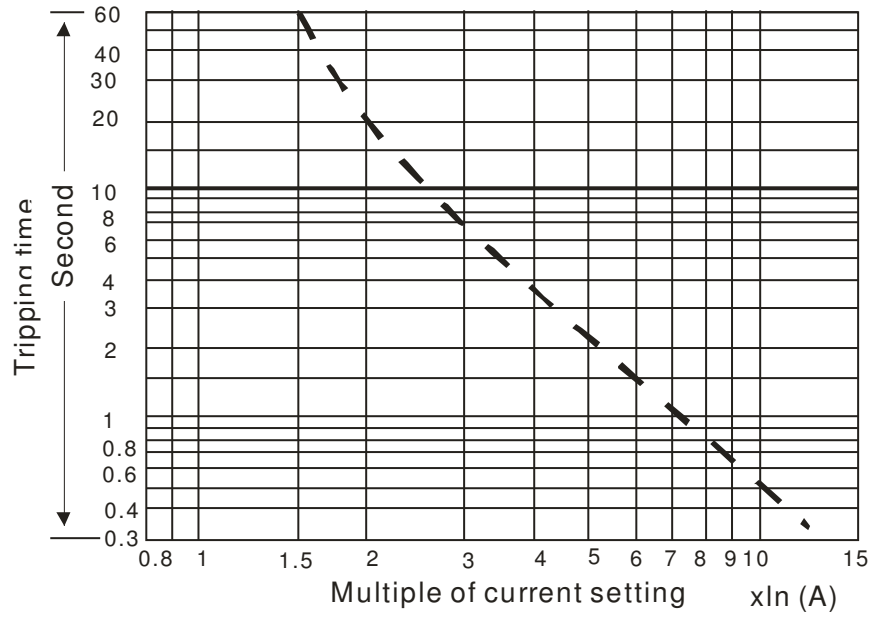

6-2 Non-fuse Circuit Breaker

Comply with UL standard: Per UL 508, paragraph 45.8.4, part a,
The rated current of the breaker shall be 2~4 times of the maximum rated input current of AC motor drive.

1-phase 230V	
Model	Recommended non-fuse breaker (A)
VFD004CB21A-20/-21/-21M	15
VFD007CB21A-20/-21/-21M	20
VFD015CB21A-20/-21/-21M	30
VFD022CB21A-20/-21/-21M	50

3-phase 230V	
Model	Recommended non-fuse breaker (A)
VFD004CB23A-20/-21/-21M	10
VFD007CB23A-20/-21/-21M	15
VFD015CB23A-20/-21/-21M	20
VFD022CB23A-20/-21/-21M	30
VFD037CB23A-20/-21/-21M	40

3-phase 460V	
Model	Recommended non-fuse breaker (A)
VFD007CB43A-20/-21/-21M	10
VFD015CB43A-20/-21/-21M	10
VFD022CB43A-20/-21/-21M VFD022CB43B-20	15
VFD037CB43A-20/-21/-21M VFD037CB43B-20	20
VFD040CB43A-20/-21/-21M VFD040CB43B-20	20
VFD055CB43A-20/-21/-21M VFD055CB43B-20	30
VFD075CB43A-20/-21/-21M VFD075CB43B-20	40

6-3 Fuse Specification Chart

- Use only the fuses comply with UL certificated.
- Use only the fuses comply with local regulations.

Model	Manufacturer	Class / Catalog No	Rating
VFD004CB21A-20/-21/-21M	Cooper Bussmann Inc.	Class _T / JJN-15	300 Vac, 15A
VFD007CB21A-20/-21/-21M		Class _T / JJN-20	300 Vac, 20A
VFD015CB21A-20/-21/-21M		Class _T / JJN-30	300 Vac, 30A
VFD022CB21A-20/-21/-21M		Class _T / JJN-50	300 Vac, 50A
VFD004CB23A-20/-21/-21M		Class _T / JJN-10	300 Vac, 10A
VFD007CB23A-20/-21/-21M		Class _T / JJN-15	300 Vac, 15A
VFD015CB23A-20/-21/-21M		Class _T / JJN-20	300 Vac, 20A
VFD022CB23A-20/-21/-21M		Class _T / JJN-30	300 Vac, 30A
VFD037CB23A-20/-21/-21M		Class _T / JJN-40	300 Vac, 40A
VFD007CB43A-20/-21/-21M		Class _T / JJS-10	600 Vac, 10A
VFD015CB43A-20/-21/-21M		Class _T / JJS-10	600 Vac, 10A
VFD022CB43A-20/-21/-21M VFD022CB43B-20		Class _T / JJS-15	600 Vac, 15A
VFD037CB43A-20/-21/-21M VFD037CB43B-20		Class _T / JJS-20	600 Vac, 20A
VFD040CB43A-20/-21/-21M VFD040CB43B-20		Class _T / JJS-20	600 Vac, 20A
VFD055CB43A-20/-21/-21M VFD055CB43B-20		Class _T / JJS-30	600 Vac, 30A
VFD075CB43A-20/-21/-21M VFD075CB43B-20		Class _T / JJS-40	600 Vac, 40A

6-4 AC/DC Reactor

AC Input Reactor

When the AC Motor Drive is connected directly to a large-capacity power transformer (500kVA or above) or when a phase lead capacitor is switched, excess peak currents may occur in the power input circuit due to the load changes and the converter section may be damaged. To avoid this, it is recommended using a serial connected AC input reactor at the AC Motor Drive mains input side to reduce the current and improve the input power efficiency.

Method of set up

AC input reactor sets up between electric power and R, S, T which are at three-phase input side of AC motor drive in series-connected way. See the figure below:

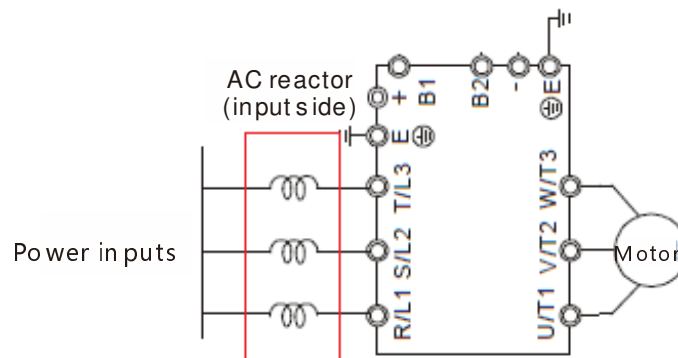

AC Input Reactor Setup

Specifications of AC input reactors (standard item)

The following table shows the specifications of AC input reactors (standard items) for Delta C200 series products, and their part numbers to choose:

200~230V, 50~60Hz, 1-phase

Type	HP	Rated Amps (Arms)	Max. continuous Amps (Arms)	3% impedance (mH)	5% impedance (mH)	Built-in DC reactor	3% input reactor Delta Part #
VFD004CB21A	0.5	3	5.04	7.844	13.073	X	DR005D0585
VFD007CB21A	1	5	8.64	4.576	7.626	X	DR008D0366
VFD015CB21A	2	8	12.78	3.094	5.155	X	DR011D0266
VFD022CB21A	3	11	18	2.197	3.660	X	DR017D0172

200~230V, 50~60Hz, 3-phase

Type	HP	Rated Amps (Arms)	Max. continuous Amps (Arms)	3% impedance (mH)	5% impedance (mH)	Built-in DC reactor	3% input reactor Delta Part #
VFD004CB23A	0.5	3	5.04	4.529	7.547	X	DR006A0405
VFD007CB23A	1	5	8.64	2.536	4.227	X	DR005A0254
VFD015CB23A	2	8	12.78	1.585	2.642	X	DR008A0159
VFD022CB23A	3	11	18	1.152	1.922	X	DR011A0115
VFD037CB23A	5	17	28.8	0.746	1.243	X	DR017AP746

380~460V, 50~60Hz, 3-phase

Type	HP	Rated Amps (Arms)	Max. continuous Amps (Arms)	3% impedance (mH)	5% impedance (mH)	Built-in DC reactor	3% input reactor Delta Part #
VFD007CB43A	1	3	5.22	8.102	13.502	X	DR003A0810
VFD015CB43A	2	4	6.84	6.077	10.127	X	DR004A0607
VFD022CB43A	3	6	10.26	4.05	6.752	X	DR006A0405
VFD037CB43A	5	9	14.58	2.7	4.501	X	DR009A0270
VFD040CB43A	5	10.5	17.1	2.315	3.858	X	DR010A0231
VFD055CB43A	7.5	12	19.8	2.025	3.375	X	DR012A0202
VFD075CB43A	10	18	30.6	1.35	2.251	X	DR018A0117
VFD022CB43B	3	6	10.26	4.05	6.752	X	DR006A0405
VFD037CB43B	5	9	14.58	2.7	4.501	X	DR009A0270
VFD040CB43B	5	10.5	17.1	2.315	3.858	X	DR010A0231
VFD055CB43B	7.5	12	19.8	2.025	3.375	X	DR012A0202
VFD075CB43B	10	18	30.6	1.35	2.251	X	DR018A0117

DC Reactor

DC reactor can increase the impedance, improve the power factor, decrease input current, increase system's capacity and decrease harmonic which generates from AC motor drive. Furthermore, DC reactor can steady the DC voltage of AC motor drive. Compare with the reactor which sets up at input side, it is small, lower price, and low pressure drop.

Method of set up

DC reactor sets up between +1 and +2 of the circuit, and the jumper should be removed. See the figure below:

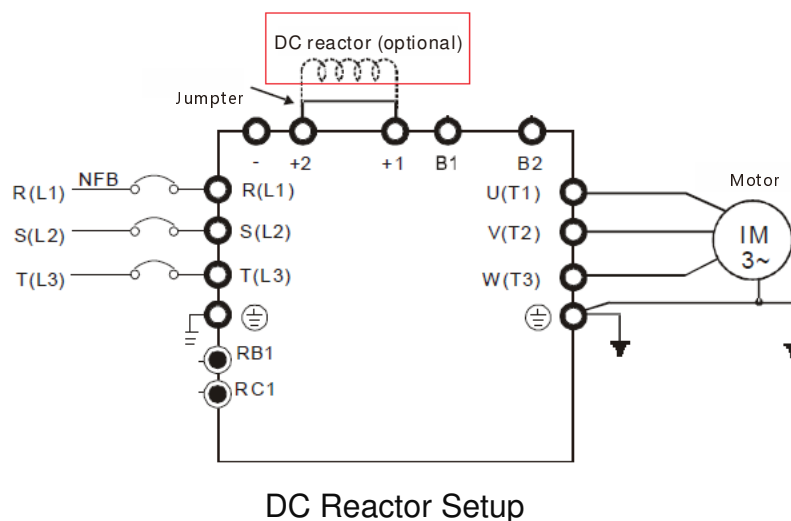

Specifications of DC reactors (standard item)

The following table shows the specifications of DC reactors (standard items) for Delta C200 series products.

200~230V, 50~60Hz, 3-phase

Type	HP	Rated Amps (Arms)	Max. continuous Amps (Arms)	DC reactor (mH)	DC reactor Delta Part#
VFD004CB23A	0.5	3	5.04	10.459	DR005D0585*
VFD007CB23A	1	5	8.64	5.857	DR005D0585
VFD015CB23A	2	8	12.78	3.66	DR008D0366
VFD022CB23A	3	11	18	2.662	DR011D0266
VFD037CB23A	5	17	28.8	1.722	DR017D0172

*The inductance is 3%

380~460V, 50~60Hz, 3-phase

Type	HP	Rated Amps (Arms)	Max. continuous Amps (Arms)	DC reactor (mH)	DC reactor Delta Part#
VFD007CB43A	1	3	5.22	18.709	DR003D1870
VFD015CB43A	2	4	6.84	14.031	DR004D1403
VFD022CB43A	3	6	10.26	9.355	DR006D0935
VFD037CB43A	5	9	14.58	6.236	DR009D0623
VFD040CB43A	5	10.5	17.1	5.345	DR010D0534
VFD055CB43A	7.5	12	19.8	4.677	DR012D0467
VFD075CB43A	10	18	30.6	3.119	DR018D0311
VFD022CB43B	3	6	10.26	9.355	DR006D0935
VFD037CB43B	5	9	14.58	6.236	DR009D0623
VFD040CB43B	5	10.5	17.1	5.345	DR010D0534
VFD055CB43B	7.5	12	19.8	4.677	DR012D0467
VFD075CB43B	10	18	30.6	3.119	DR018D0311

The following table is spec. of THDi that Delta AC motor drives use with AC/DC reactors.

AC motor drive	Without built-in DC reactor (Frame A~C)				With built-in DC reactor (Frame D and above)		
	Without adding input AC/DC reactor	3% Input AC Reactor	5% Input AC Reactor	4% DC Reactor	Built-in DC reactor, and without adding input AC/DC reactor	3% Input AC Reactor	5% Input AC Reactor
5th	73.3%	38.5%	30.8%	25.5%	31.16%	27.01%	25.5%
7th	52.74%	15.3%	9.4%	18.6%	23.18%	9.54%	8.75%
11th	7.28%	7.1%	6.13%	7.14%	8.6%	4.5%	4.2%
13th	0.4%	3.75%	3.15%	0.48%	7.9%	0.22%	0.17%
THDi	91%	43.6%	34.33%	38.2%	42.28%	30.5%	28.4%
Note	THDi may have some difference due to different installation conditions and environment						

According to IEC61000-3-12, DC reactor is designed as 4% of system impedance, and AC reactor is 3% of system impedance.

AC Output Reactor

If the length of cable between AC motor drive and motor is too long, it may make AC motor drive trigger protection mechanism for GF (Ground Fault), OV (Over Current) and the AC motor drive stops running. The cause is the over long motor cable will generate extremely large stray capacitance, make common mode current of 3-phase output get too large and then trigger GF protection mechanism; OC protection is triggered which is caused by stray capacitance of cable-cable and cable-ground are getting larger, and its surge current makes AC motor drive output over large current. To prevent from the common mode current that stray capacitance generates, set up AC output reactor between AC motor drive and motor to increase the high frequency impedance.

Power transistor is switched via PWM to control the output voltage and frequency for AC motor drive. During the switch process, impulse voltage (dv/dt) rises and falls rapidly will make inner voltage of motor distribute unequally, and then the isolation of motor will be getting worse, and have interference of bearing current and electromagnet. Especially when AC motor drive and motor are connected by long leading wire, the influence of damping of high frequency resonance and reflected voltage that caused by cable spreading parameters is getting large, and it will generate twice incoming voltage at motor side to be over voltage, destroy the isolation.

Method of set up

AC output reactor sets up between motor and U, V, W which are at output side of AC motor drive in series-connected way. See the figure below:

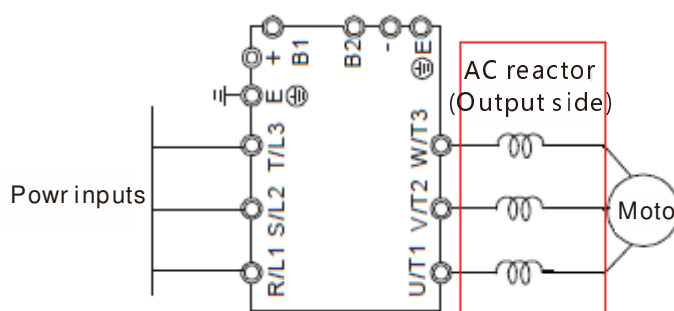

AC Output Reactor Setup

Specifications of AC output reactors (standard item)

The following table shows the specifications of AC output reactors (standard items) for Delta C200 series products, and their part numbers to choose:

200~230V, 50~60Hz, 1-phase

Type	HP	Rated Amps (Arms)	Max. continuous Amps (Arms)	3% impedance (mH)	5% impedance (mH)	Built-in DC reactor	3% input reactor Delta Part #
VFD004CB21A	0.5	3	5.04	7.844	13.073	X	N/A
VFD007CB21A	1	5	8.64	4.576	7.626	X	N/A
VFD015CB21A	2	8	12.78	3.094	5.155	X	N/A
VFD022CB21A	3	11	18	2.197	3.660	X	N/A

200~230V, 50~60Hz, 3-phase

Type	HP	Rated Amps (Arms)	Max. continuous Amps (Arms)	3% impedance (mH)	5% impedance (mH)	Built-in DC reactor	3% input reactor Delta Part #
VFD004CB23A	0.5	3	5.04	4.529	7.547	X	N/A
VFD007CB23A	1	5	8.64	2.536	4.227	X	N/A
VFD015CB23A	2	8	12.78	1.585	2.642	X	N/A
VFD022CB23A	3	11	18	1.152	1.922	X	N/A
VFD037CB23A	5	17	28.8	0.746	1.243	X	N/A

380~460V, 50~60Hz, 3-phase

Type	HP	Rated Amps (Arms)	Max. continuous Amps (Arms)	3% impedance (mH)	5% impedance (mH)	Built-in DC reactor	3% input reactor Delta Part #
VFD007CB43A	1	3	5.22	8.102	13.502	X	N/A
VFD015CB43A	2	4	6.84	6.077	10.127	X	N/A
VFD022CB43A	3	6	10.26	4.05	6.752	X	N/A
VFD037CB43A	5	9	14.58	2.7	4.501	X	N/A
VFD040CB43A	5	10.5	17.1	2.315	3.858	X	N/A
VFD055CB43A	7.5	12	19.8	2.025	3.375	X	N/A
VFD075CB43A	10	18	30.6	1.35	2.251	X	N/A
VFD022CB43B	3	6	10.26	4.05	6.752	X	N/A
VFD037CB43B	5	9	14.58	2.7	4.501	X	N/A
VFD040CB43B	5	10.5	17.1	2.315	3.858	X	N/A
VFD055CB43B	7.5	12	19.8	2.025	3.375	X	N/A
VFD075CB43B	10	18	30.6	1.35	2.251	X	N/A

The length of motor cable

- Never connect phase lead capacitors or surge absorbers to the output terminals of the AC motor drive.
 - If the length is too long, the stray capacitance between cables will increase and may cause leakage current. It will activate the protection of over current, increase leakage current or not insure the correction of current display. The worst case is that AC motor drive may damage.
 - If more than one motor is connected to the AC motor drive, the total wiring length is the sum of the wiring length from AC motor drive to each motor.
 - For the 460V series AC motor drive, when an overload relay is installed between the drive and the motor to protect motor over heating, the connecting cable must be shorter than 50m. However, an overload relay malfunction may still occur. To prevent the malfunction, install an output reactor (optional) to the drive or lower the carrier frequency setting (Pr.00-17).
- When motor is driven by an AC motor drive of PWM type, the motor terminals will experience surge voltages easily due to components conversion of AC motor drive and cable capacitance. When the motor cable is very long (especially for the 460V series), surge voltages may reduce insulation quality. To prevent this situation, please follow the rules below:

- Use a motor with enhanced insulation.
- Connect an output reactor (optional) to the output terminals of the AC motor drive
- The length of the cable between AC motor drive and motor should be as short as possible (10 to 20 m or less)

- The following table refers to IEC 60034-17 shows specification of the length of shielding cable for C200 series motor. It applies to the motors which rated voltage is under 500Vac, peak-peak voltage isolation rating is above (including) 1.35kV:

220V / 1-phase	HP	Rated Amps (Arms)	Without AC output reactor		3% AC output reactor	
			Shielding cable (meter)	Un-shielding cable (meter)	Shielding cable (meter)	Un-shielding cable (meter)
VFD004CB21A	0.5	3	50	75	75	115
VFD007CB21A	1	5	50	75	75	115
VFD015CB21A	2	8	50	75	75	115
VFD022CB21A	3	11	50	75	75	115

220V / 3-phase	HP	Rated Amps (Arms)	Without AC output reactor		3% AC output reactor	
			Shielding cable (meter)	Un-shielding cable (meter)	Shielding cable (meter)	Un-shielding cable (meter)
VFD004CB23A	0.5	3	50	75	75	115
VFD007CB23A	1	5	50	75	75	115
VFD015CB23A	2	8	50	75	75	115
VFD022CB23A	3	11	50	75	75	115
VFD037CB23A	5	17	50	75	75	115

440V/ 3-phase	HP	Rated Amps (Arms)	Without AC output reactor		3% AC output reactor	
			Shielding cable (meter)	Un-shielding cable (meter)	Shielding cable (meter)	Un-shielding cable (meter)
VFD007CB43A	1	3	50	75	75	115
VFD015CB43A	2	4	50	75	75	115
VFD022CB43A	3	6	50	75	75	115
VFD037CB43A	5	9	50	75	75	115
VFD040CB43A	5	10.5	50	75	75	115
VFD055CB43A	7.5	12	50	75	75	115
VFD075CB43A	10	18	100	150	150	225
VFD022CB43B	3	6	50	75	75	115
VFD037CB43B	5	9	50	75	75	115
VFD040CB43B	5	10.5	50	75	75	115
VFD055CB43B	7.5	12	50	75	75	115
VFD075CB43B	10	18	100	150	150	225

6-5 Zero Phase Reactors

RF220X00A

UNIT: mm (inch)

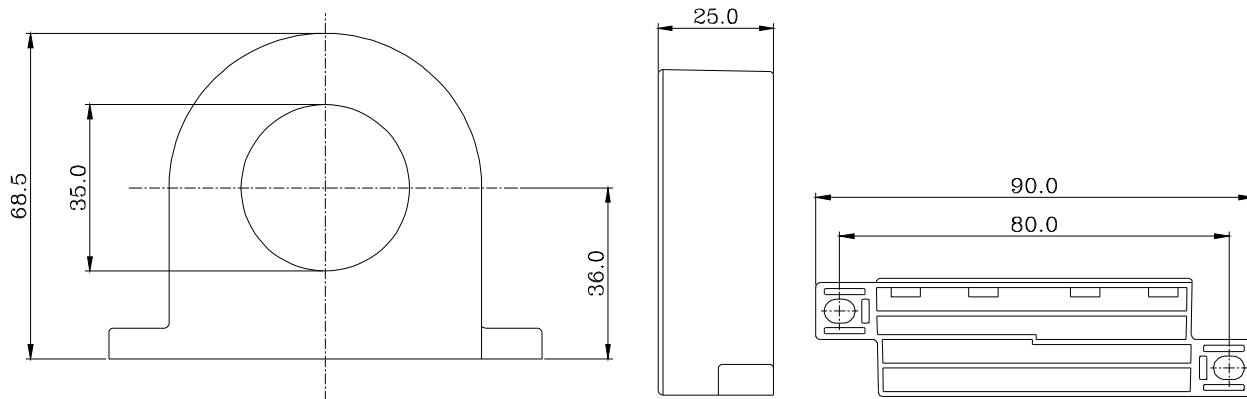

Cable type (Note)	Recommended Wire Size (mm ²)			Qty.	Wiring Method
	AWG	mm ²	Nominal (mm ²)		
Single-core	≤10	≤5.3	≤5.5	1	Diagram A
	≤2	≤33.6	≤38	4	Diagram B
Three-core	≤12	≤3.3	≤3.5	1	Diagram A
	≤1	≤42.4	≤50	4	Diagram B

NOTE

600V insulated cable wire

1. The table above gives approximate wire size for the zero phase reactors but the selection is ultimately governed by the type and the diameter of the cable, i.e. the cable diameter must small enough to go through the center of the zero phase reactor.
2. When wiring, do not goes through the earth core. It only needs to pass through the motor cable or the power cable.
3. When a long motor cable for output is used, a zero phase reactor may be necessary to reduce the radiated emission.

Diagram A

Wind each wire around the core for 4 times. The reactor must be placed at the AC motor drive output side as close as possible.

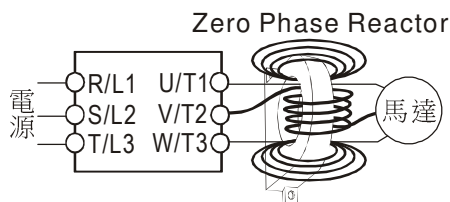
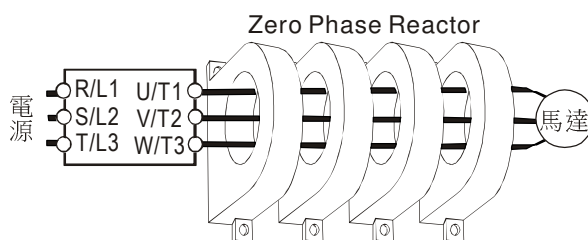

Diagram B

Put the wires/cables through the middle of the 4 cores that lines in parallel.



6-6 EMI Filter

The following table shows external EMI filter models. Users can choose corresponding zero phase reactor and applicable shielding cable according to required noise emission and electromagnetic disturbance rating, to make the best assembly and restrain electromagnetic disturbance.

Model	Input Current	Applicable EMI Filter	Zero Phase Reactor	CE Cable Length		Radiation Emission	
				Default Carrier Frequency			
				EN61800-3		EN61800-3	
				C2	C2	C2	C2
VFD004CB21A-20/-21/-21M	7.2	EMF011A21A	RF008X00A	100	100	100	100
VFD007CB21A-20/-21/-21M	12			100	100	100	100
VFD015CB21A-20/-21/-21M	15.7	EMF023A21A		100	100	100	100
VFD022CB21A-20/-21/-21M	22			100	100	100	100
VFD004CB23A-20/-21/-21M	3.9	EMF014A23A		100	100	100	100
VFD007CB23A-20/-21/-21M	6.4			100	100	100	100
VFD015CB23A-20/-21/-21M	12			100	100	100	100
VFD022CB23A-20/-21/-21M	16	EMF021A23A		100	100	100	100
VFD037CB23A-20/-21/-21M	20			100	100	100	100
VFD007CB43A-20/-21/-21M	4.3	EMF014A43A		100	100	100	100
VFD015CB43A-20/-21/-21M	5.9			100	100	100	100
VFD022CB43A-20/-21/-21M VFD022CB43B-20	8.7			100	100	100	100
VFD037CB43A-20/-21/-21M VFD037CB43B-20	14			100	100	100	100
VFD040CB43A-20/-21/-21M VFD040CB43B-20	15.5	EMF018A43A		100	100	100	100
VFD055CB43A-20/-21/-21M VFD055CB43B-20	17			100	100	100	100
VFD075CB43A-20/-21/-21M VFD075CB43B-20	20			100	100	100	100

EMI Filter Installation

All electrical equipment, including AC motor drives, will generate high-frequency/low-frequency noise and will interfere with peripheral equipment by radiation or conduction when in operation. By using an EMI filter with correct installation, much interference can be eliminated. It is recommended to use DELTA EMI filter to have the best interference elimination performance.

We assure that it can comply with following rules when AC motor drive and EMI filter are installed and wired according to user manual:

- **EN61000-6-4**
- **EN61800-3: 1996**
- **EN55011 (1991) Class A Group 1 (1st Environment, restricted distribution)**

General precaution

1. EMI filter and AC motor drive should be installed on the same metal plate.
2. Please install AC motor drive on footprint EMI filter or install EMI filter as close as possible to the AC motor drive.
3. Please wire as short as possible.
4. Metal plate should be grounded.
5. The cover of EMI filter and AC motor drive or grounding should be fixed on the metal plate and the contact area should be as large as possible.

Choose suitable motor cable and precautions

Improper installation and choice of motor cable will affect the performance of EMI filter. Be sure to observe the following precautions when selecting motor cable.

1. Use the cable with shielding (double shielding is the best).
2. The shielding on both ends of the motor cable should be grounded with the minimum length and maximum contact area.
3. Remove any paint on metal saddle for good ground contact with the plate and shielding.

Remove any paint on metal saddle for good ground contact with the plate and shielding.

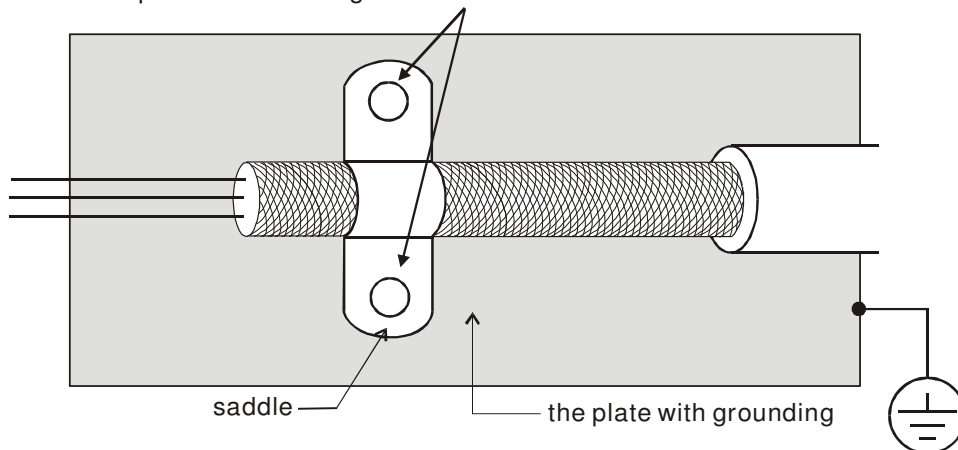

Figure 1

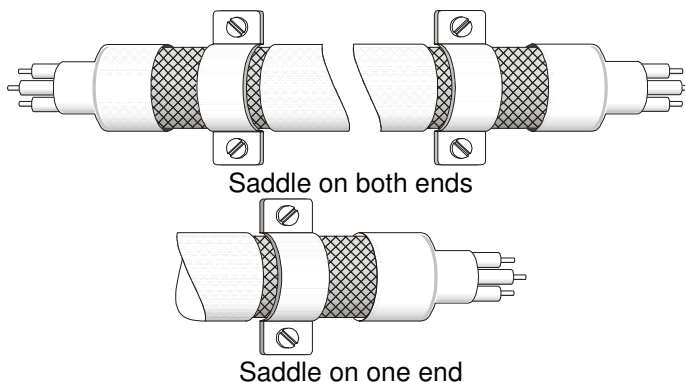

Figure 2

6-7 Digital Keypad

KPC-CC01



KPC-CE01













Communication Interface
RJ-45 (socket) · RS-485 interface;

Installation Method
Embedded type and can be put flat on the surface of the control box. The front cover is water proof.

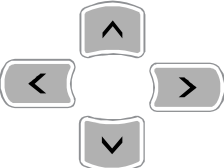



NOTE Multi-lingual display are NOT supported when using C200 with KPC-CC01, it only can display in English.

Descriptions of Keypad Functions

Key	Descriptions																		
	<p>Start Operation Key</p> <ol style="list-style-type: none"> 1. It is only valid when the source of operation command is from the keypad. 2. It can operate the AC motor drive by the function setting and the RUN LED will be ON. 3. It can be pressed again and again at stop process. 4. When enabling "HAND" mode, it is only valid when the source of operation command is from the keypad. 																		
	<p>Stop Command Key. This key has the highest processing priority in any situation.</p> <ol style="list-style-type: none"> 1. When it receives STOP command, no matter the AC motor drive is in operation or stop status, the AC motor drive needs to execute "STOP" command. 2. The RESET key can be used to reset the drive after the fault occurs. For those faults that can't be reset by the RESET key, see the fault records after pressing MENU key for details. 																		
	<p>Operation Direction Key</p> <ol style="list-style-type: none"> 1. This key is only control the operation direction NOT for activate the drive. FWD: forward, REV: reverse. 2. Refer to the LED descriptions for more details. 																		
	<p>ENTER Key Press ENTER and go to the next level. If it is the last level then press ENTER to execute the command.</p>																		
	<p>ESC Key ESC key function is to leave current menu and return to the last menu. It is also functioned as a return key in the sub-menu.</p>																		
	<p>Press menu to return to main menu. Menu content: KPC-CE01 does not support function 5 ~13.</p> <table border="0"> <tr> <td>1. Detail Parameter</td> <td>7. Quick/Simple Setup</td> <td>13. PC Link</td> </tr> <tr> <td>2. Copy Parameter</td> <td>8. Display Setup</td> <td></td> </tr> <tr> <td>3. Keypad Locked</td> <td>9. Time Setup</td> <td></td> </tr> <tr> <td>4. PLC Function</td> <td>10. Language Setup</td> <td></td> </tr> <tr> <td>5. Copy PLC</td> <td>11. Startup Menu</td> <td></td> </tr> <tr> <td>6. Fault Record</td> <td>12. Main Page</td> <td></td> </tr> </table>	1. Detail Parameter	7. Quick/Simple Setup	13. PC Link	2. Copy Parameter	8. Display Setup		3. Keypad Locked	9. Time Setup		4. PLC Function	10. Language Setup		5. Copy PLC	11. Startup Menu		6. Fault Record	12. Main Page	
1. Detail Parameter	7. Quick/Simple Setup	13. PC Link																	
2. Copy Parameter	8. Display Setup																		
3. Keypad Locked	9. Time Setup																		
4. PLC Function	10. Language Setup																		
5. Copy PLC	11. Startup Menu																		
6. Fault Record	12. Main Page																		
	<p>Direction: Left/Right/Up/Down</p> <ol style="list-style-type: none"> 1. In the numeric value setting mode, it is used to move the cursor and change the numeric value. 2. In the menu/text selection mode, it is used for item selection. 																		

Key	Descriptions
	<p>Function Key</p> <ol style="list-style-type: none"> It has the factory setting function and the function can be set by the user. The present factory setting: F1 is JOG function. Other functions must be defined by TPEditor first. TPEditor software V1.30.6 (or later) is available for download at: http://www.delta.com.tw/ch/product/em/download/download_main.asp?act=3&pid=3&cid=3&tpid=3
	<p>HAND ON Key</p> <ol style="list-style-type: none"> This key is executed by the parameter settings of the source of Hand frequency and hand operation. The factory settings of both source of Hand frequency and hand operation are the digital keypad. Press HAND ON key at stop status, the setting will switch to hand frequency source and hand operation source. Press HAND ON key at operation status, it stops the AC motor drive first (display AHSP warning), and switch to hand frequency source and hand operation source. Successful mode switching for KPC-CE01, "H/A" LED will be on; for KPC-CC01, it will display HAND mode/ AUTO mode on the screen.
	<ol style="list-style-type: none"> This key is executed by the parameter settings of the source of AUTO frequency and AUTO operation. The factory setting is the external terminal (source of operation is 4-20mA). Press Auto key at stop status, the setting will switch to hand frequency source and hand operation source. Press Auto key at operation status, it stops the AC motor drive first (display AHSP warning), and switch to hand frequency source and hand operation source. Successful mode switching for KPC-CE01, "H/A" LED will be off; for KPC-CC01, it will display HAND mode/ AUTO mode on the screen

Descriptions of LED Functions

LED	Descriptions
	<p>Steady ON: operation indicator of the AC motor drive, including DC brake, zero speed, standby, restart after fault and speed search.</p> <p>Blinking: drive is decelerating to stop or in the status of base block.</p> <p>Steady OFF: drive doesn't execute the operation command</p>
	<p>Steady ON: stop indicator of the AC motor drive.</p> <p>Blinking: drive is in the standby status.</p> <p>Steady OFF: drive doesn't execute "STOP" command.</p>
	<p>Operation Direction LED</p> <ol style="list-style-type: none"> Green light is on, the drive is running forward. Red light is on, the drive is running backward. Twinkling light: the drive is changing direction.
	<p>(Only KPC-CE01 support this function)</p> <p>Setting can be done during operation.</p> <p>HAND LED: When HAND LED is on (HAND mode); when HAND LED is off (AUTO mode).</p>
	<p>(Only KPC-CE01 Support this function)</p> <p>Setting can be done during operation.</p> <p>AUTO LED: when AUTO LED is on (AUTO mode); when AUTO LED is off (HAND mode).</p>

Dimension of KPC-CC01 & KPC-CE01

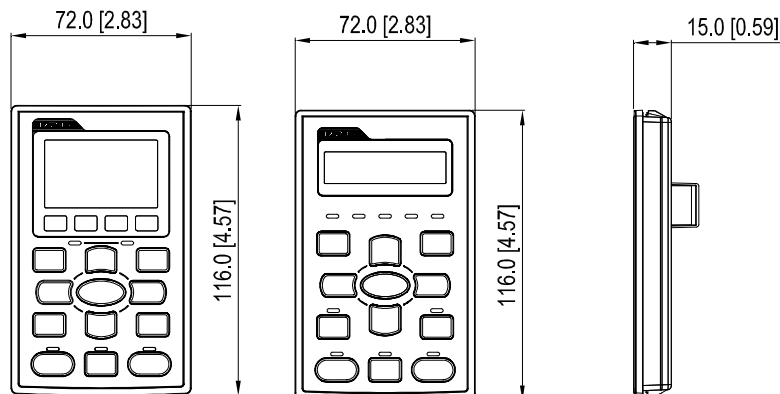

6-8 Panel Mounting (MKC-KPPK)

For MKC-KPPK model, user can choose wall mounting or embedded mounting, protection level is IP56.

Applicable to the digital keypads (KPC-CC01 & KPC-CE01).

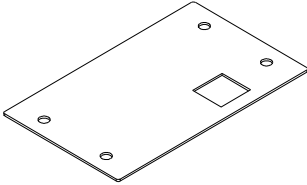
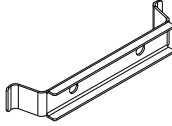
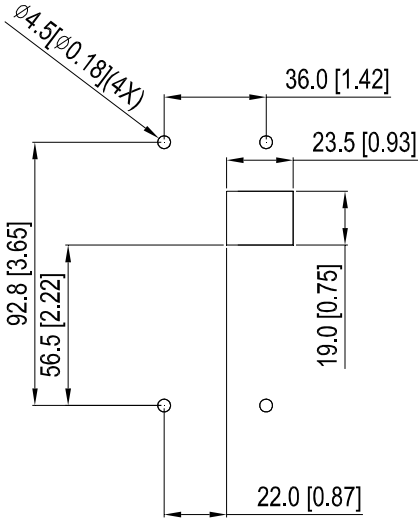
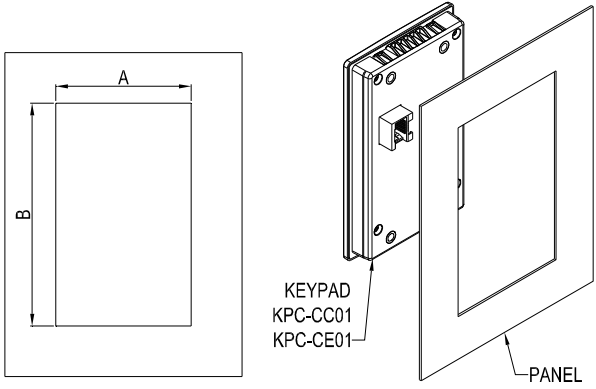
Wall Mounting		Embedded Mounting													
accessories*1 		accessories*2 													
Screw *4 ~M4*p 0.7 *L8mm Torque: 10-12kg-cm (8.7-10.4lb-in.)		Screw *4 ~M4*p 0.7 *L8mm Torque: 10-12kg-cm (8.7-10.4lb-in.)													
Panel cutout dimension Unit: mm [inch]		Panel cutout dimension Unit: mm [inch]													
															
		Normal cutout dimension													
		<table border="1"> <thead> <tr> <th>Panel thickness</th> <th>1.2mm</th> <th>1.6mm</th> <th>2.0mm</th> </tr> </thead> <tbody> <tr> <td>A</td> <td colspan="3">66.4 [2.614]</td> </tr> <tr> <td>B</td> <td>110.2 [4.339]</td> <td>111.3 [4.382]</td> <td>112.5 [4.429]</td> </tr> </tbody> </table>		Panel thickness	1.2mm	1.6mm	2.0mm	A	66.4 [2.614]			B	110.2 [4.339]	111.3 [4.382]	112.5 [4.429]
Panel thickness	1.2mm	1.6mm	2.0mm												
A	66.4 [2.614]														
B	110.2 [4.339]	111.3 [4.382]	112.5 [4.429]												
		*Deviation: ±0.15mm /±0.0059inch													
		Cutout dimension (Waterproof level: IP56)													
		<table border="1"> <thead> <tr> <th>Panel thickness</th> <th>1.2mm</th> <th>1.6mm</th> <th>2.0mm</th> </tr> </thead> <tbody> <tr> <td>A</td> <td colspan="3">66.4 [2.614]</td> </tr> <tr> <td>B</td> <td colspan="3">110.8 [4.362]</td> </tr> </tbody> </table>		Panel thickness	1.2mm	1.6mm	2.0mm	A	66.4 [2.614]			B	110.8 [4.362]		
Panel thickness	1.2mm	1.6mm	2.0mm												
A	66.4 [2.614]														
B	110.8 [4.362]														
		*Deviation: ±0.15mm /±0.0059inch													

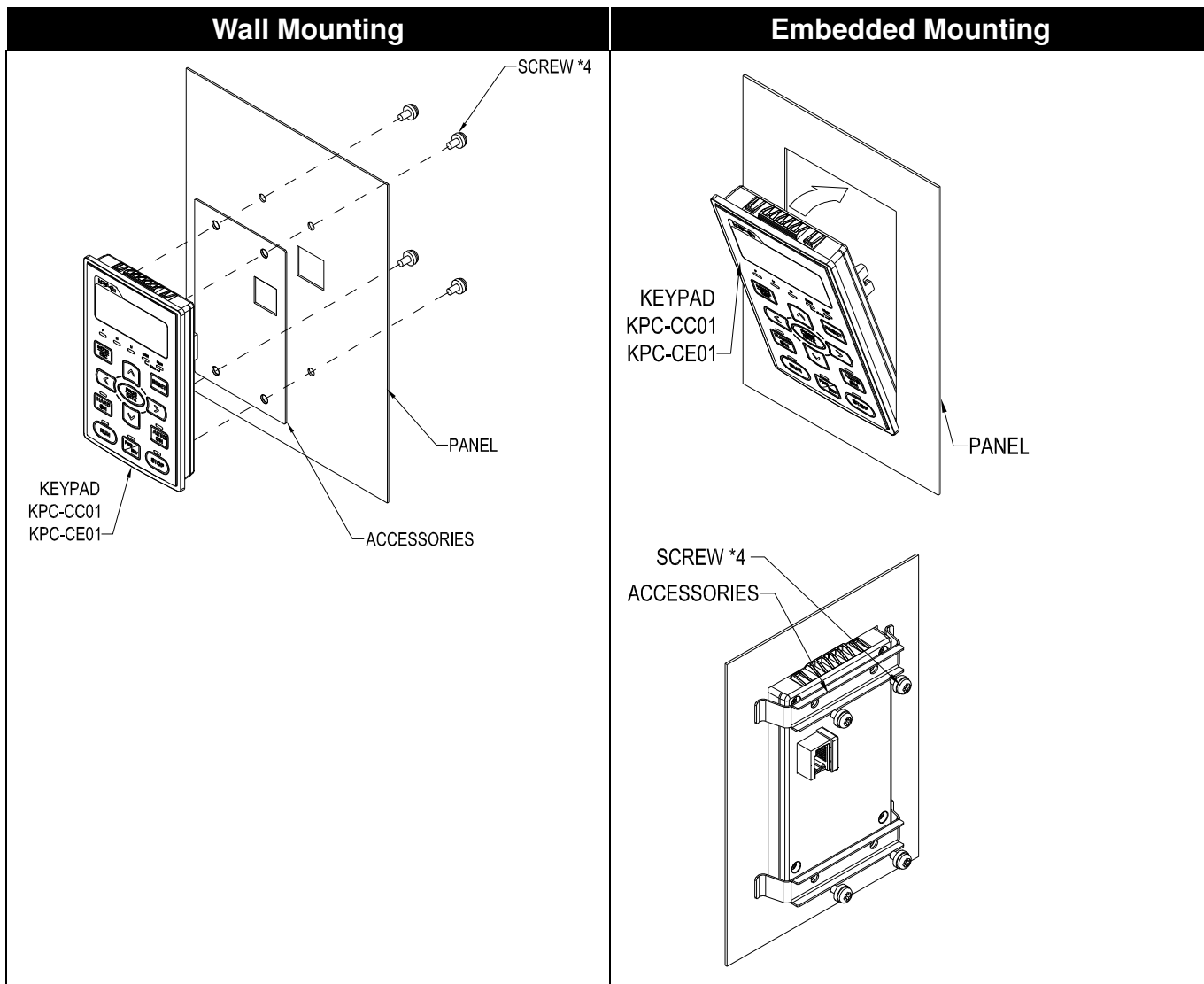

RJ45 Extension Lead for Digital Keypad
 (Designed only for KEYPAD • NOT for CANopen communication)

Part #	Description
CBC-K3FT	3 feet RJ45 extension lead (approximately 0.9m)
CBC-K5FT	5 feet RJ45 extension lead (approximately 1.5 m)
CBC-K7FT	7 feet RJ45 extension lead (approximately 2.1 m)
CBC-K10FT	10 feet RJ45 extension lead (approximately 3 m)
CBC-K16FT	16 feet RJ45 extension lead (approximately 4.9 m)

6-9 Conduit Box

■ Appearance

Frame A0

Applicable models:

VFD004CB21A-20/-21/-21M; VFD007CB21A-20/-21/-21M; VFD004CB23A-20/-21/-21M;
 VFD007CB23A-20/-21/-21M; VFD015CB23A-20/-21/-21M; VFD007CB43A-20/-21/-21M;
 VFD015CB43A-20/-21/-21M; VFD015CB21A-20/-21/-21M; VFD022CB21A-20/-21/-21M;
 VFD022CB23A-20/-21/-21M; VFD037CB23A-20/-21/-21M; VFD022CB43A-20/-21/-21M;
 VFD037CB43A-20/-21/-21M

Model name: MKCB-A0N1

Item	Description	Qty
1	SCREW M3*0.5*8L	4
2	BUSHING RUBBER 28	4
3	BUSHING RUBBER 20	1
4	CONDUIT BOX COVER	1
5	CONDUIT BOX BASE	1

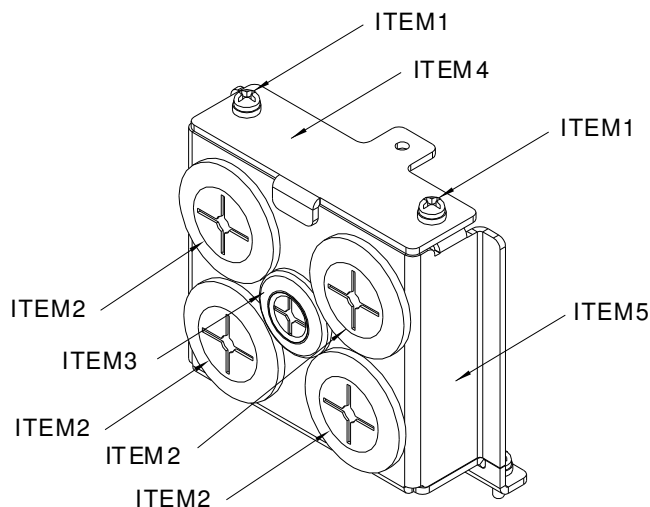

■ Installation of Conduit Box

Frame A0

1. Disassemble the wiring cover, and loosen the screws of wiring guard.

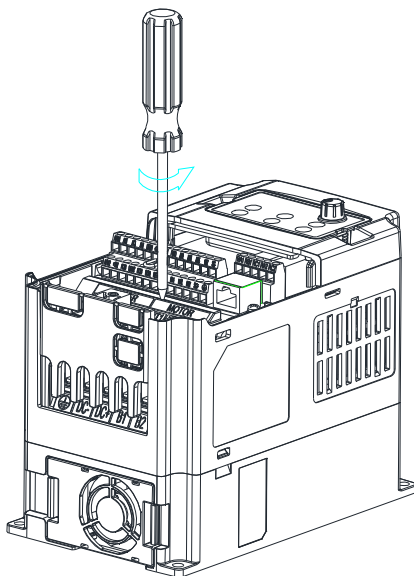

NOTE: C200-21/-21M are NO wiring guard.

2. Fasten the conduit box with the screws. Screw torque: 8-10Kg-cm (6.9-8.7lb-in.)

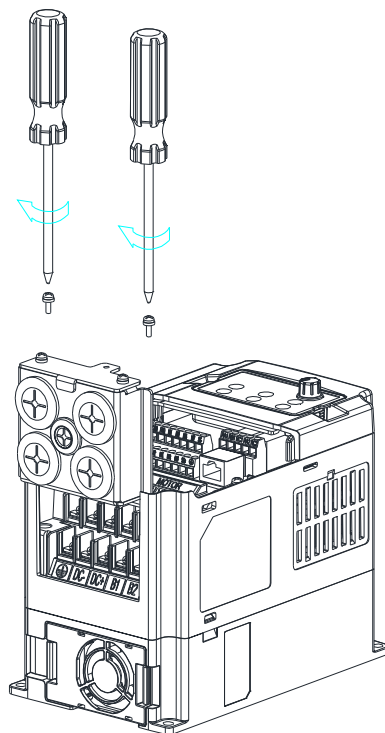

3. Place the wiring cover back and fasten it with screws. Screw M3 torque: 6-8Kg-cm (5.2-6.9lb-in.)

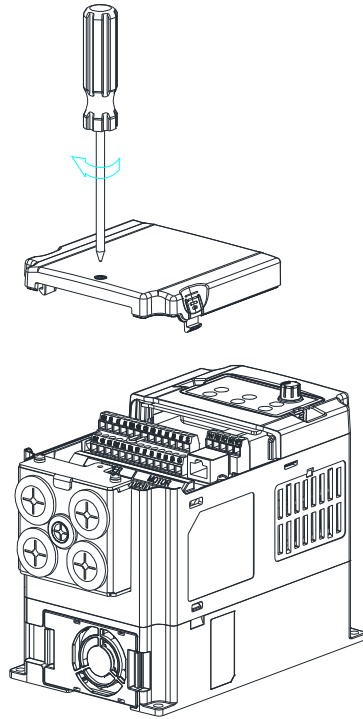

6-10 Fan Kit

■ Frames of the fan kit

Model 『MKCB-A0FKM』

This fan is a 12Vdc ON/OFF control fan

Applicable Model:

VFD015CB23A-20/-21/-21M

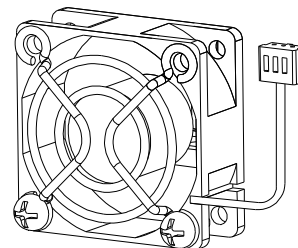

Model 『MKCB-AFKM1』

This fan is a 12Vdc ON/OFF control fan

Applicable Model:

VFD015CB21A-20/-21/-21M; VFD022CB21A-20/-21/-21M;
VFD022CB23A-20/-21/-21M; VFD037CB23A-20/-21/-21M;
VFD022CB43A-20/-21/-21M; VFD037CB43A-20/-21/-21M;
VFD040CB43A-20/-21/-21M; VFD055CB43A-20/-21/-21M

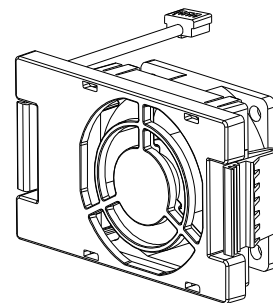

Model 『MKCB-AFKM2』

This fan is a 12Vdc PWM control fan

Applicable Model:

VFD075CB43A-20/-21/-21M

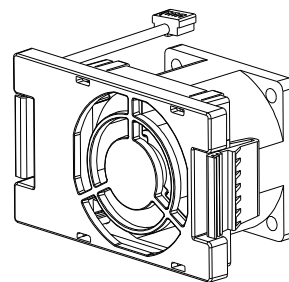

Model 『MKCB-AFKM3』

This fan is a 12Vdc ON/OFF control fan

Applicable Model:

VFD022CB43B-20; VFD037CB43B-20; VFD040CB43B-20;
VFD055CB43B-20; VFD075CB43B-20

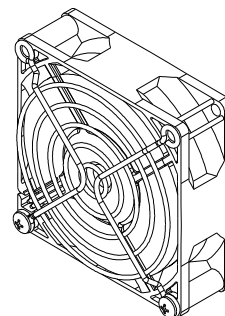

■ Fan Removal

Frame A0

Applicable model:

VFD015CB21A-20/-21/-21M; VFD022CB21A-20/-21/-21M; VFD022CB23A-20/-21/-21M;
VFD037CB23A-20/-21/-21M; VFD022CB43A-20/-21/-21M; VFD037CB43A-20/-21/-21M

1. Press the tabs on both side of the fan to successfully remove the fan. (The arrow)
2. Disconnect the power terminal before removing the fan. (As shown below.)

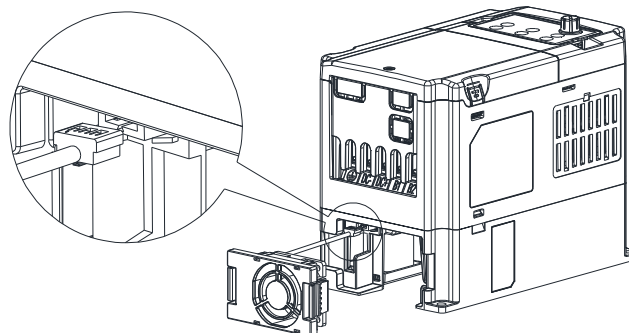
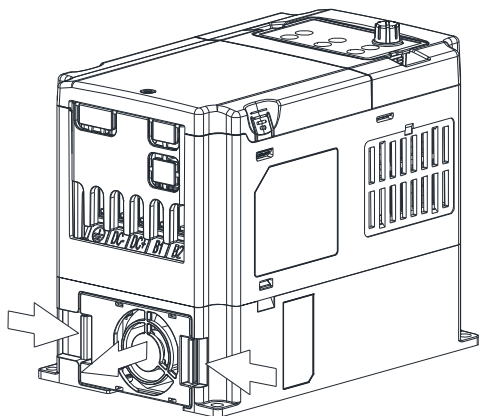

Frame A0

Applicable model:

VFD015CB23A-20/-21/-21M

1. Disconnect the power terminal before removing the fan. (As shown below)
2. Loosen the two screws to remove the fan. Screw torque: 8-10kg-cm (6.9-8.7lb-in.)

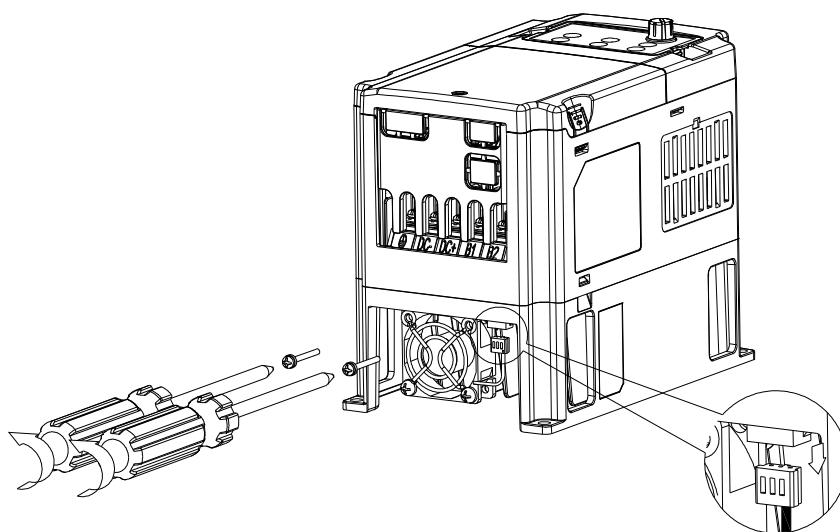
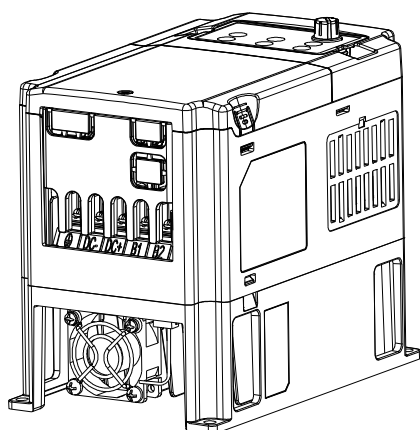

Frame A

Applicable model:

VFD040CB43A-20/-21/-21M; VFD055CB43A-20/-21/-21M; VFD075CB43A-20/-21/-21M

1. Press the tabs on both side of the fan to successfully remove the fan. (The arrow)

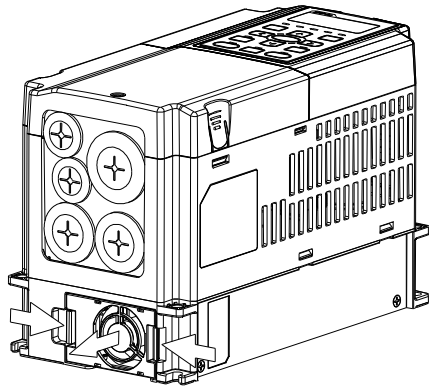

2. Disconnect the power terminal before removing the fan. (As shown below.)

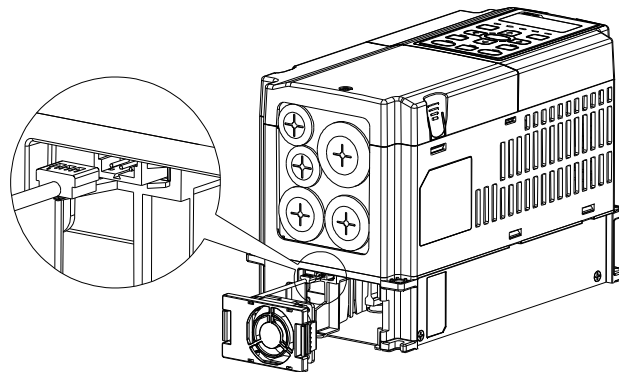

Frame A0 & A

Applicable model:

VFD022CB43B-20; VFD037CB43B-20; VFD040CB43B-20; VFD055CB43B-20;
VFD075CB43B-20

1. Loosen the two screws, and then the fan can be removed.

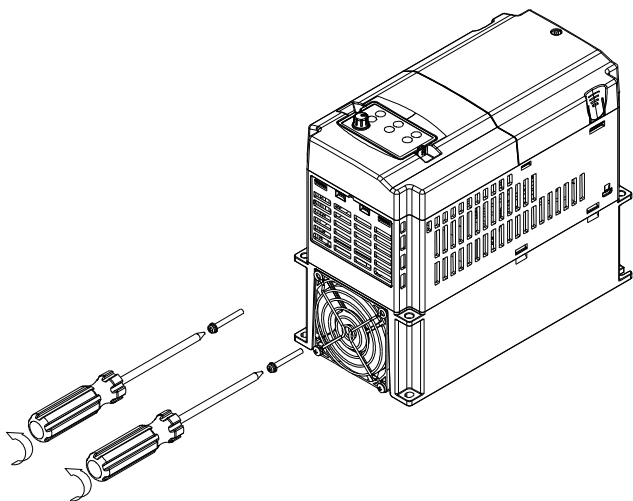

2. Disconnect the power terminal before removing the fan. (As the figure shown below)

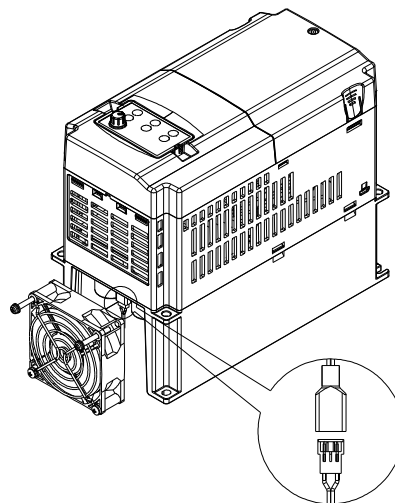

- ※ 1 VFD040CB43A-20/-21/-21M; VFD055CB43A-20/-21/-21M: optional fan model# 『MKCB-AFKM1』 .
This fan is a 12Vdc ON/OFF control fan.
- ※ 2 VFD075CB43A-20/-21/-21M: optional fan model # 『MKCB-AFKM2』 .
This fan is a 12Vdc PWM control fan.

6-11 USB/RS-485 Communication Interface IFD6530

Warning

- ✓ Please thoroughly read this instruction sheet before installation and putting it into use.
- ✓ The content of this instruction sheet and the driver file may be revised without prior notice. Please consult our distributors or download the most updated instruction/driver version at http://www.delta.com.tw/product/em/control/cm/control_cm_main.asp

1. Introduction

IFD6530 is a convenient RS-485-to-USB converter, which does not require external power-supply and complex setting process. It supports baud rate from 75 to 115.2kbps and auto switching direction of data transmission. In addition, it adopts RJ-45 in RS-485 connector for users to wire conveniently. And its tiny dimension, handy use of plug-and-play and hot-swap provide more conveniences for connecting all DELTA IABU products to your PC.

Applicable Models: All DELTA IABU products.

(Application & Dimension)

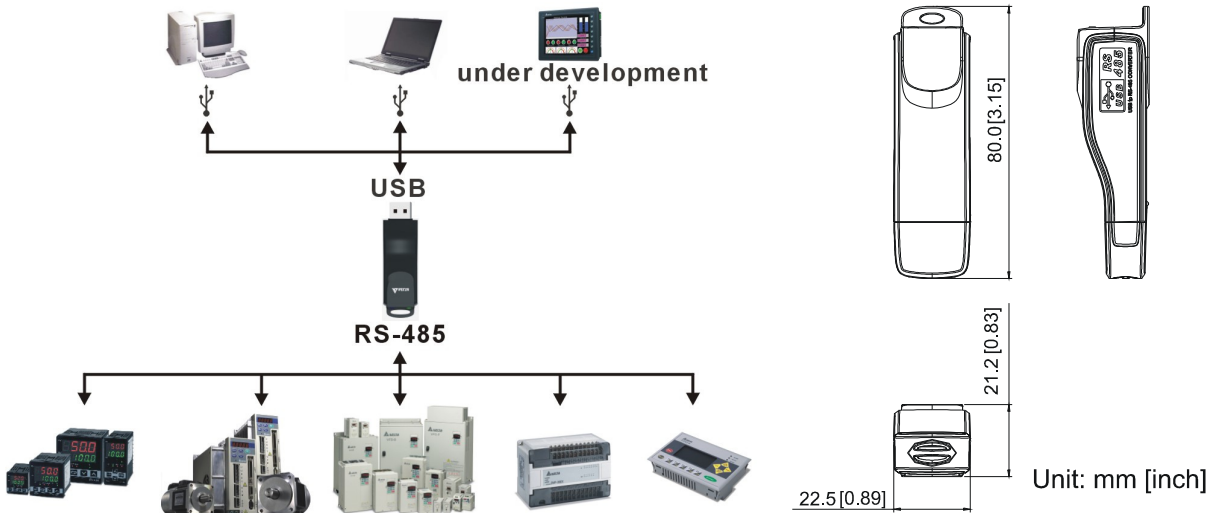

2. Specifications

Power supply	No external power is needed
Power consumption	1.5W
Isolated voltage	2,500VDC
Baud rate	75, 150, 300, 600, 1,200, 2,400, 4,800, 9,600, 19,200, 38,400, 57,600, 115,200 bps
RS-485 connector	RJ-45
USB connector	A type (plug)
Compatibility	Full compliance with USB V2.0 specification
Max. cable length	RS-485 Communication Port: 100 m
Support RS-485 half-duplex transmission	

■ RJ-45

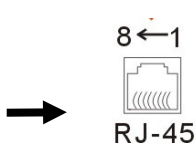

PIN	Description
1	Reserved
2	Reserved
3	GND
4	SG-

PIN	Description
5	SG+
6	GND
7	Reserved
8	+9V

MKCB-HUB01 Multi-Function Communication Expansion Card

In order to coordinate with the integrity of parallel communication between RS485 and CANopen, Delta has introduced a multi-function communication expansion card.

Via RS-232 communication port of a computer, connect RS232/RS485 communication interface to any terminal of a communication board MKCB-HUB01. Then connect parallelly to one or more VFDs to di multi-function communication control.

MODBUS RS-485&CANopen Application

MODBUS RS-485

When using MODBUS RS-485, set the terminal resistor's PIN short of the last VFD at 120Ω. And the terminal resistor's PIN short of the rest of VFD need to be set at OPEN.

CANopen

When using CANopen, connect the MKCB-HUB1 of the last VFD to a terminal resistor.

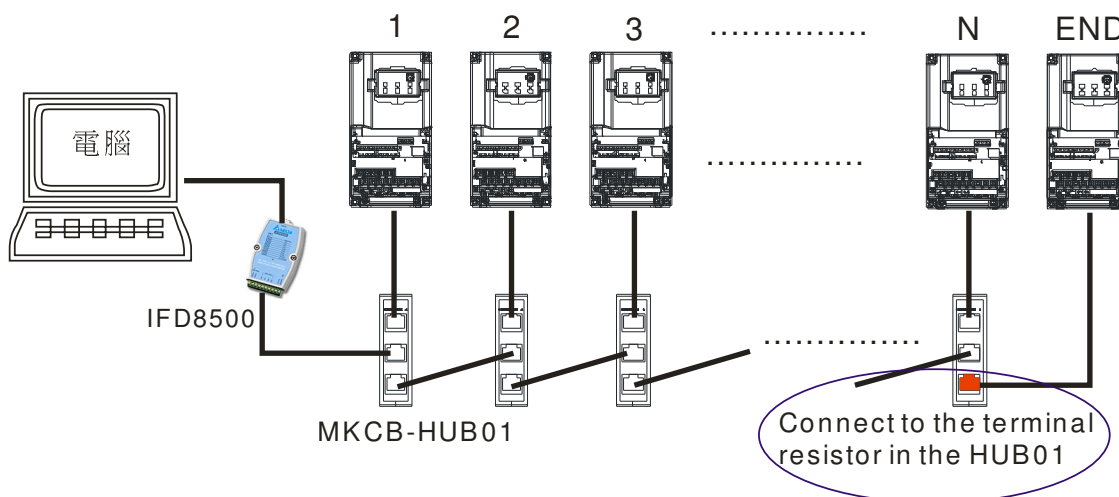

C200 RJ-45 PIN definition

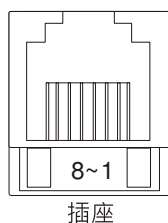

Pin	Signal	Note
1	CAN_H	CAN_H bus line (dominant high)
2	CAN_L	CAN_L bus line (dominant low)
3	CAN_GND	Ground/0V/V-
4	SG-	
5	SG+	
6	NC	
7	CAN_GND	Ground/0V/V-
8	EV	

Terminal resistor

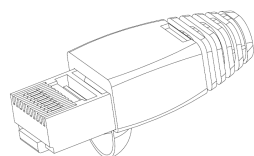

Pin	Note
1~2	120Ω 1/4W
3~8	NC

CANopen communication cable

Model no.: TAP-CB03, TAP-CB04

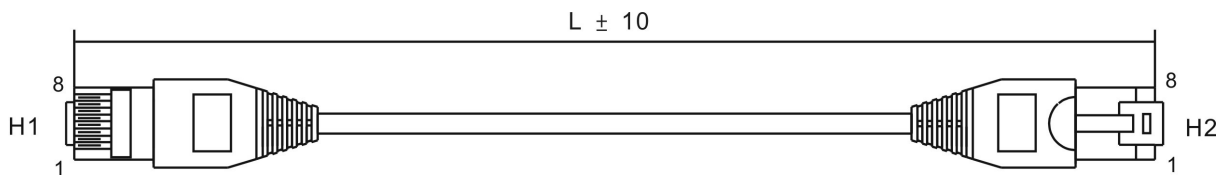

Title	Part No.	L	
		mm	inch
1	TAP-CB03	500 ± 10	19 ± 0.4
2	TAP-CB04	1000 ± 10	39 ± 0.4

Dimensions

Unit: mm [inch]

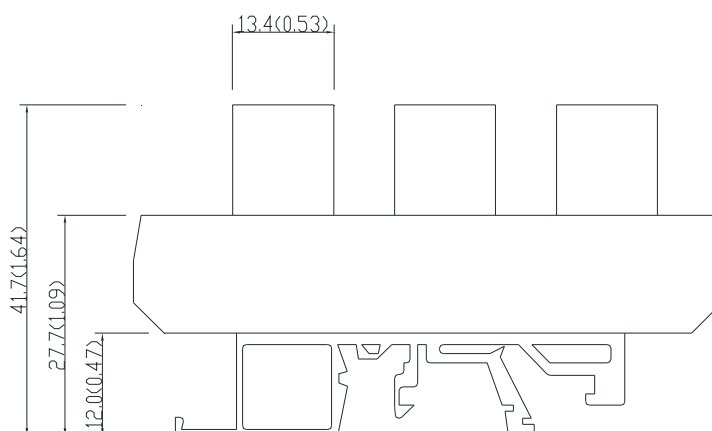
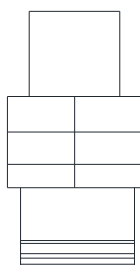
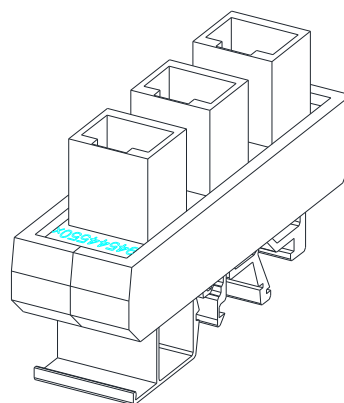
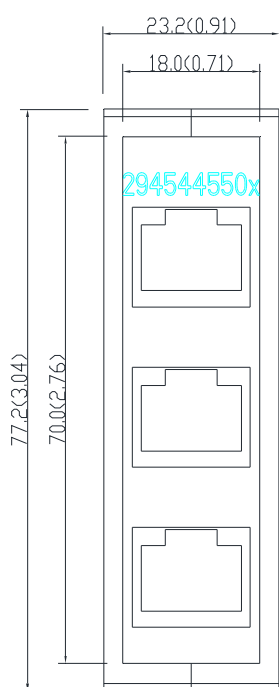

Chapter 7 Specification

230V Series -1 Phase

Frame Size		A0				
Model VFD - __CB21A-__ ^{*1}		004	007	015	022	
Applicable Motor Output (kW)		0.4	0.75	1.5	2.2	
Applicable Motor Output (HP)		0.5	1	2	3	
Output Rating	Normal Duty	Rated Output Capacity (kVA)	1.2	2.0	3.2	4.4
		Rated Output Current (A)	3	5	8	11
		Overload Tolerance	Rated output current is 120% for 60 seconds; Rated output current is 160% for 2 seconds			
		Max. Output Frequency (Hz)	600.00Hz			
		Carrier Frequency (kHz)	2~15kHz (Factory Setting: 8 kHz)			
	Heavy Duty	Rated Output Capacity (kVA)	1.1	1.9	2.8	4.0
		Rated Output Current (A)	2.8	4.8	7.1	10
		Overload Tolerance	rated output current is 150% for 60 seconds; rated output current is 180% for 3 seconds			
		Max. Output Frequency (Hz)	300.00Hz			
		Carrier Frequency (kHz)	2~15kHz (Factory Setting: 2 kHz)			
Input Rating	Input Current (A) Normal Duty	7.2	12	15.7	22	
	Input Current (A) Heavy Duty	6.7	11.5	14	20	
	Rated Voltage/Frequency	AC 200V~240V (-15% ~ +10%), 50/60Hz, 1-Phase				
	Operating Voltage Range	170~265Vac				
	Frequency Tolerance	47~63Hz				
Cooling method		Natural cooling		Fan cooling		
Braking Chopper		Built-in				

*1 : __ __ " means models such as -20 / -21 / -21M.

230V Series -3 Phase

Frame Size		A0					
Model VFD - __CB23A-__ ^{*1}		004	007	015	022	037	
Applicable Motor Output (kW)		0.4	0.75	1.5	2.2	3.7	
Applicable Motor Output (HP)		0.5	1	2	3	5	
Output Rating	Normal Duty	Rated Output Capacity (kVA)	1.2	2.0	3.2	4.4	6.8
		Rated Output Current (A)	3	5	8	11	17
		Overload Tolerance	Rated output current is 120% for 60 seconds; Rated output current is 160% for 2 seconds				
		Max. Output Frequency (Hz)	600.00Hz				
		Carrier Frequency (kHz)	2~15kHz (Factory Setting: 8 kHz)				
	Heavy Duty	Rated Output Capacity (kVA)	1.1	1.9	2.8	4.0	6.4
		Rated Output Current (A)	2.8	4.8	7.1	10	16
		Overload Tolerance	rated output current is 150% for 60 seconds; rated output current is 180% for 3 seconds				
		Max. Output Frequency (Hz)	300.00Hz				
		Carrier Frequency (kHz)	2~15kHz (Factory Setting: 2 kHz)				
Input Rating	Input Current (A) Normal Duty	3.9	6.4	12	16	20	
	Input Current (A) Heavy Duty	3.6	6.1	11	15	18.5	
	Rated Voltage/Frequency	AC 200V~240V (-15% ~ +10%), 50/60Hz, 3-Phase					
	Operating Voltage Range	170~265Vac					
	Frequency Tolerance	47~63Hz					
Cooling method		Natural cooling		Fan cooling			
Braking Chopper		Built-in					

*1 : __ __ " means models such as -20 / -21 / -21M.

460V Series





Frame Size		A0				A			
Model VFD-__CB43A-__ ^{*1}		007	015	022	037	040	055	075	
Applicable Motor Output (kW)		0.75	1.5	2.2	3.7	4.0	5.5	7.5	
Applicable Motor Output (HP)		1	2	3	5	5.5	7.5	10	
Output Rating	Normal Duty	Rated Output Capacity (kVA)	2.4	3.2	4.8	7.2	8.4	10	14
		Rated Output Current (A)	3.0	4.0	6.0	9.0	10.5	12	18
		Overload Tolerance	Rated output current is 120% for 60 seconds; Rated output current is 160% for 3 seconds						
		Max. Output Frequency (Hz)	600.00Hz						
		Carrier Frequency (kHz)	2~15kHz (Factory Setting: 8 kHz)						
	Heavy Duty	Rated Output Capacity (kVA)	2.3	3.0	4.5	6.5	7.6	9.6	14
		Rated Output Current (A)	2.9	3.8	5.7	8.1	9.5	11	17
		Overload Tolerance	Rated output current is 150% for 60 seconds; Rated output current is 180% for 3 seconds						
		Max. Output Frequency (Hz)	300.00Hz						
		Carrier Frequency (kHz)	2~15kHz (Factory Setting: 2 kHz)						
Input Rating	Input Current (A) Normal Duty		4.3	5.9	8.7	14	15.5	17	20
	Input Current (A) Heavy Duty		4.1	5.6	8.3	13	14.5	16	19
	Rated Voltage/Frequency		AC 380V~480V (-15% ~ +10%), 50/60Hz, 3-Phase						
	Operating Voltage Range		323~528Vac						
	Frequency Tolerance		47~63Hz						
Cooling method		Natural cooling			Fan cooling				
Braking Chopper		Built-in							

*1 : __ __ " means models such as -20 / -21 / -21M.

460V Series (Fan enlarged)

Frame Size		A0		A			
Model VFD-__CB43B-__		022	037	040	055	075	
Applicable Motor Output (kW)		2.2	3.7	4.0	5.5	7.5	
Applicable Motor Output (HP)		3	5	5.5	7.5	10	
Output Rating	Normal Duty	Rated Output Capacity (kVA)	4.8	7.2	8.4	10	14
		Rated Output Current (A)	6.0	9.0	10.5	12	18
		Overload Tolerance	Rated output current is 120% for 60 seconds; Rated output current is 160% for 3 seconds				
		Max. Output Frequency (Hz)	600.00Hz (High speed mode: 2,000 Hz, refer to the setting of Pr.00-14)				
		Carrier Frequency (kHz)	2~15kHz (Factory Setting: 8 kHz)				
	Heavy Duty	Rated Output Capacity (kVA)	4.5	6.5	7.6	9.6	14
		Rated Output Current (A)	5.7	8.1	9.5	11	17
		Overload Tolerance	Rated output current is 150% for 60 seconds; Rated output current is 180% for 3 seconds				
		Max. Output Frequency (Hz)	600.00Hz				
		Carrier Frequency (kHz)	2~15kHz (Factory Setting: 2 kHz)				
Output Rating	Input Current (A) Normal Duty		8.7	14	15.5	17	20
	Input Current (A) Heavy Duty		8.3	13	14.5	16	19
	Rated Voltage/Frequency		AC 380V~480V (-15% ~ +10%), 50/60Hz, 3-Phase				
	Operating Voltage Range		323~528Vac				
	Frequency Tolerance		47~63Hz				
Cooling method		Fan cooling					
Braking Chopper		Built-in					

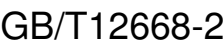
General Specifications

Control Characteristics	Control Method	1: V/F, 2: SVC, 3: VF+PG, 4: FOC+PG,
	Starting Torque	Reach up to 150% or above at 0.5Hz. Under FOC+PG mode, starting torque can reach 150% at 0Hz.
	Speed Response Ability	5Hz (vector control can reach up to 40Hz)
	Torque Limit	Max. 200% torque current
	Torque Accuracy	±5%
	Max. Output Frequency (Hz)	normal duty: 0.00~600.00Hz; Heavy duty: 0.00 ~ 300.00 Hz
	Frequency Output Accuracy	Digital command:±0.01%, -10°C~+40°C, Analog command: ±0.1%, 25±10°C
	Output Frequency Resolution	Digital command:0.01Hz, Analog command: 0.03 X max. output frequency/60 Hz (±11 bit)
	Frequency Setting Signal	+10V~-10V, 0~+10V, 4~20mA, 0-20mA
	Accel./decel. Time	0.00~600.00 seconds or 0.0~6000.0 seconds
Main control function	Torque control, Droop control, Speed/torque control switching, Feed forward control, Zero-servo control, Momentary power loss ride thru, Speed search, Over-torque detection, Torque limit, 16-step speed (max), Accel/decel time switch, S-curve accel/decel, 3-wire sequence, Auto-Tuning (rotational, stationary), Dwell, Cooling fan on/off switch, Slip compensation, Torque compensation, JOG frequency, Frequency upper/lower limit settings, DC injection braking at start/stop, High slip braking, PID control (with sleep function), Energy saving control, MODBUS communication (RS-485 RJ45, max. 115.2 kbps), Fault restart, Parameter copy	
Fan Control	User Pr07-19 to control cooling fans.	
Protection Characteristics	Motor Protection	Electronic thermal relay protection
	Over-current Protection	For drive model 230V and 460V Over-current protection for 240% rated current current clamp 『Normal duty: 170~175%』; 『Heavy duty: 180~185%』
	Over-voltage Protection	230: drive will stop when DC-BUS voltage exceeds 410V 460: drive will stop when DC-BUS voltage exceeds 820V
	Over-temperature Protection	Built-in temperature sensor
	Grounding Leakage Current Protection	Stall prevention during acceleration, deceleration and running independently Leakage current is higher than 50% of rated current of the AC motor drive
Certifications	   	

Environment for Operation, Storage and Transportation

DO NOT expose the AC motor drive in the bad environment, such as dust, direct sunlight, corrosive/inflammable gasses, humidity, liquid and vibration environment. The salt in the air must be less than 0.01mg/cm² every year.

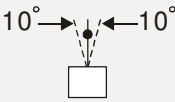
Environment	Installation location	IEC60364-1/IEC60664-1 Pollution degree 2, Indoor use only		
	Surrounding Temperature	Storage	-25°C ~ +70°C	
		Transportation	-25°C ~ +70°C	
				Only allowed at non-condensation, non-frozen, non-conductive pollution environment
	Rated Humidity	Operation	Max. 95%	
		Storage/Transportation	Max. 95%	
				Only allowed at non-condensation, non-frozen, non-conductive pollution environment
	Air Pressure	Operation/Storage	86 to 106 kPa	
		Transportation	70 to 106 kPa	
	Pollution Level	IEC721-3-3		
Operation		Class 3C2; Class 3S2		
Storage		Class 1C2; Class 1S2		
Transportation		Class 2C2; Class 2S2		
			Only allowed at non-condensation, non-frozen, non-conductive pollution environment	
Altitude	Operation	If AC motor drive is installed at altitude 0~1000m, follow normal operation restriction. If it is install at altitude 1000~3000m, decrease 2% of rated current or lower 0.5°C of temperature for every 100m increase in altitude. Maximum altitude for Corner Grounded is 2000m.		
Package Drop	Storage	ISTA procedure 1A(according to weight) IEC60068-2-31		
	Transportation			
Vibration	1.0mm, peak to peak value range from 2Hz to 13.2 Hz; 0.7G~1.0G range from 13.2Hz to 55Hz; 1.0G range from 55Hz to 512 Hz. Comply with IEC 60068-2-6			
Impact	IEC/EN 60068-2-27			
Operation Position	Max. allowed offset angle ±10° (under normal installation position)			

Specification for Operation Temperature and Protection Level

Model	Frame	Top cover	Conduit Box
VFDxxxCBxxA-20	Frame A0~A 230V: 0.4~3.7kW 460V: 0.75~7.5kW	IP20 / UL Open Type	-10~50°C
VFDxxxCBxxA-21	Frame A0~A 230V: 0.4~3.7kW 460V: 0.75~7.5kW	IP20 / NEMA1	-10~40°C
VFDxxxCBxxA-21M*1	Frame A0~A 230V: 0.4~3.7kW 460V: 0.75~7.5kW	IP20 / NEMA1	-10~40°C
VFDxxxCBxxB-20	Frame A0~A 460V: 2.2~7.5kW	IP20 / UL Open Type	-10~50°C

*1: The model names end by "-21M" are models which have strengthen cover cases. When the temperature is between -10~35°C, the rated current remains at 100%, but if the temperature increases to 36°C, the rated current will start to decrease by 2% as the temperature increases by 1°C.



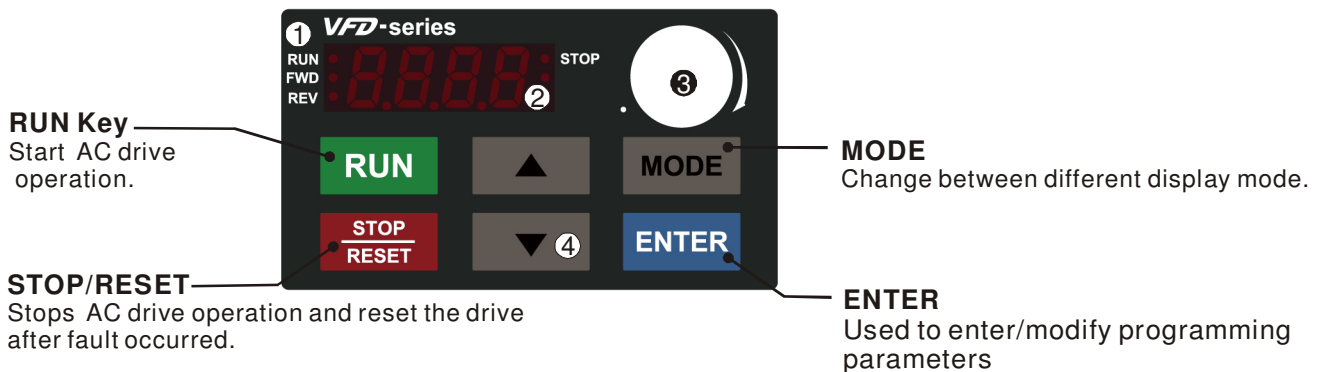

Chapter 8 Digital Keypad

Description of the Digital Keypad KPE-LE02



- ① **Status Display**
Display the driver's current status.
- ② **LED Display**
Indicates frequency, voltage, current, user defined units and etc.
- ③ **Potentiometer**
For master Frequency setting.
- ④ **UP and DOWN Key**
Set the parameter number and changes the numerical data, such as Master Frequency.

Display Message	Descriptions
RUN ● FWD ● REV ● F60.0 ● STOP	Displays the AC drive Master Frequency.
RUN ● FWD ● REV ● H50.0 ● STOP	Displays the actual output frequency at terminals U/T1, V/T2, and W/T3.
RUN ● FWD ● REV ● U180 ● STOP	User defined unit (where $U = F \times Pr.00.05$)
RUN ● FWD ● REV ● A 5.0 ● STOP	Displays the output current at terminals U/T1, V/T2, and W/T3.
RUN ● FWD ● REV ● F-r-d ● STOP	Displays the AC motor drive forward run status.
RUN ● FWD ● REV ● r-E-v ● STOP	Displays the AC motor drive reverse run status.
RUN ● FWD ● REV ● c 20 ● STOP	The counter value (C).
RUN ● FWD ● REV ● 06.00 ● STOP	Displays the selected parameter.
RUN ● FWD ● REV ● 10 ● STOP	Displays the actual stored value of the selected parameter.

	<p>External Fault.</p>
	<p>Display “End” for approximately 1 second if input has been accepted by pressing ENTER key. After a parameter value has been set, the new value is automatically stored in memory. To modify an entry, use the  and  keys.</p>
	<p>Display “Err”, if the input is invalid.</p>

 **NOTE**

When the setting exceeds 99.99 for those numbers with 2 decimals (i.e. unit is 0.01), it will only display 1 decimal due to 4-digital display.

How to Operate the Digital Keypad

Setting Mode

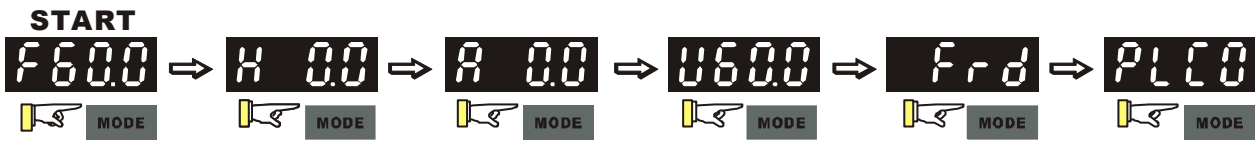

GO START

NOTE: In the selection mode, press **ENTER** to set the parameters.

Setting parameters



NOTE :In the parameter setting mode, you can press **ENTER** to return the selecting mode.

To shift data



Setting direction (When operation source is digital keypad)

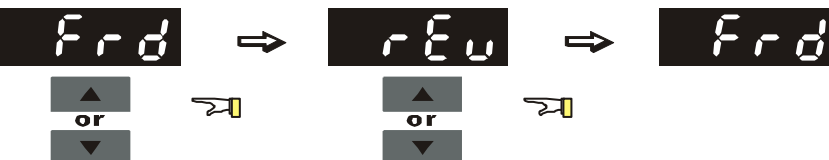

Setting PLC Mode

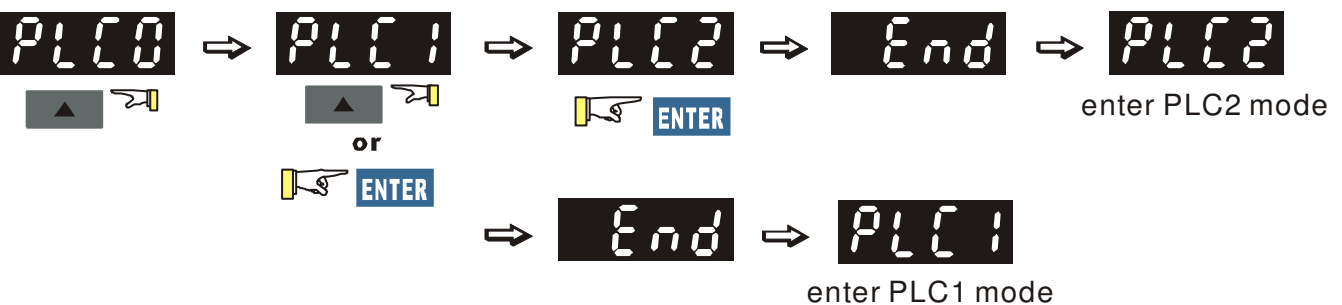

Reference Table for the 7-segment LED Display of the Digital Keypad

Number	0	1	2	3	4	5	6	7	8	9
Seven Segment Display										
English letter	A	a	B	C	c	D	d	E	e	F
Seven Segment Display		-	-			-			-	
English letter	f	G	g	H	h	I	i	J	j	K
Seven Segment Display	-		-							
English letter	k	L	l	M	m	N	n	O	o	P
Seven Segment Display	-		-		-	-				
English letter	p	Q	q	R	r	S	s	T	t	U
Seven Segment Display	-	-		-			-			
English letter	u	V	v	W	w	X	x	Y	y	Z
Seven Segment Display	-	-		-	-	-	-		-	
English letter	z									
Seven Segment Display	-									

Keypad Dimensions

Dimensions are in millimeter [inch]

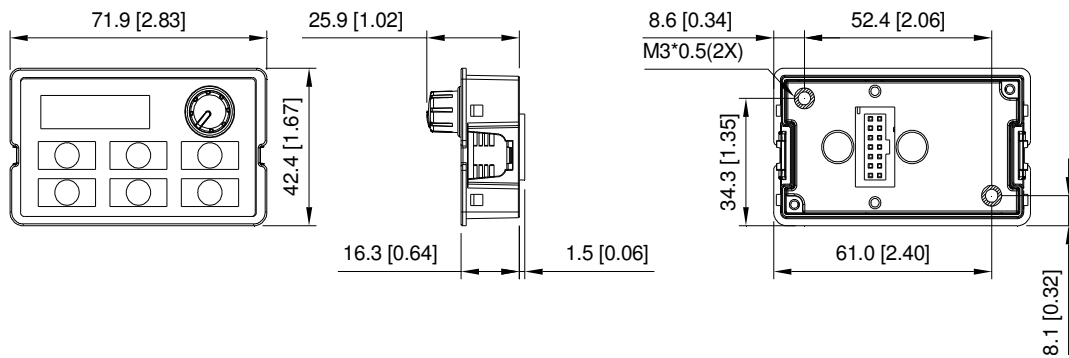

Chapter 9 Summary of Parameter Settings

This chapter provides summary of parameter settings for user to gather the parameter setting ranges, factory settings and set parameters. The parameters can be set, changed and reset by the digital keypad.

NOTE

- 1) : the parameter can be set during operation
- 2) For more details on parameters, please refer to Chapter10 Description of Parameter Settings.
- 3) All parameters will reset as factory default settings once Pr. 00-14 changes. Thus set the parameter first before executing other parameter settings.

00 Drive Parameters

 NOTE IM: Induction Motor; PM: Permanent Magnet Motor

Parameter	Explanation	Settings	Factory Setting
00-00	Identity Code of the AC Motor Drive	2:230V, 04kW 4: 230V, 1HP 5: 460 V, 1HP 6: 230V,2HP 7: 460 V, 2HP 8: 230V, 3HP 9: 460 V, 3HP 10: 230V, 5HP 11: 460 V, 5HP 12: 230V, 7.5HP 13: 460 V, 7.5HP 14: 230V, 10HP 15: 460V, 10HP 93: 460V, 5HP (4kW)	Read only
00-01	Display AC Motor Drive Rated Current	Display by models	Read only
00-02	Parameter Reset	0: No function 1: Read only 5: Reset KWH display to 0 6: Reset PLC (includes CANopen index - Master) 7: Reset CANopen Index (Slave) 9: All parameters are reset to factory settings(base frequency is 50Hz) 10: All parameters are reset to factory settings (base frequency is 60Hz)	0
 00-03	Start-up Display Selection	0: F (frequency command) 1: H (output frequency) 2: U (multi-function display, see Pr.00-04) 3: A (output current)	0

Parameter	Explanation	Settings	Factory Setting
⚡ 00-04	Content of Multi-function Display	0: Display output current (A) 1: Display counter value (c) 2: Display actual output frequency (H.) 3: Display DC-BUS voltage (v) 4: Display output voltage (E) 5: Display output power angle (n) 6: Display output power in kW (P) 7: Display actual motor speed rpm (r) 8: Display estimate output torque % (t) 9: Reserved 10: Display PID feedback in % (b) 11: Display AVI in % (1.) 12: Display ACI in % (2.) 13: Display AUI in % (3.) 14: Display the temperature of IGBT in oC (i.) 15: Display the heat sink in oC (c.) 16: The status of digital input (ON/OFF) (i) 17: The status of digital output (ON/OFF) (o) 18: Multi-step speed (S) 19: The corresponding CPU pin status of digital input (d) 20: The corresponding CPU pin status of digital output (0.) 21~24: Reserved 25: Overload count (0.00~100.00%) (h.) 26: Ground Fault GFF (Unit :%)(G.) 27: DC Bus voltage ripple (Unit: Vdc) (r.) 28: Display PLC data D1043 (C) 29: Reserved 30: Display output of user defined (U) 31: Display Pr.00-05 user Gain (K) 32~34: Reserved 35: Control Mode display: 0= Speed control mode (SPD) 1= torque control mode (TQR) (t.) 36: Present operating carrier frequency of drive (Hz) (J.)	3
00-05	Coefficient Gain in Actual Output Frequency	0~160.00	0
00-06	Software Version	Read only	##
⚡ 00-07	Parameter Protection Password Input	0~65535 0~3: the times of password attempts	0
⚡ 00-08	Parameter Protection Password Setting	0 ~ 65535 0: No password protection / password is entered correctly (Pr00-07) 1: Parameter is locked	0

Parameter	Explanation	Settings	Factory Setting
00-09	Reserved	-	-
00-10	Control Mode	0: Speed mode (Pr. 00.11) 1: Reserved 2: Torque mode (Pr. 00-13) 3: Reserved	0
00-11	Control of Speed Mode	0: VF (IM V/F control) 1: VFPG (IM V/F control+ Encoder) 2: SVC (IM Sensorless vector control) 3: FOCPG (IM FOC vector control+ encoder) 4: Reserved 5: FOC Sensorless (IM field oriented sensorless vector control) 6: PM Sensorless (PM field oriented sensorless vector control)	0
00-12	Reserved	-	-
00-13	Torque Mode Control	0: TQCPG (IM torque control + Encoder) 1: Reserved 2: TQC Sensorless (IM sensorless torque control)	0
00-14	High Speed Mode	0: Standard mode 1↵2↵: Enable 1↵0↵: Disable	0
00-15	Reserved	-	-
00-16	Load Selection	0: Normal load 1: Heavy load	0
00-17	Carrier Frequency	Normal load: 2~15HP Heavy load: 2~15HP	6
00-18	Single or Three-phase setting	0: 3-phase 1: 1-phase	Read only
00-19	PLC Command Mask	bit 0: Control command by PLC force control bit 1: Frequency command by PLC force control bit 3: Torque command by PLC force control	Read only
00-20	Source of Master Frequency Command (AUTO)	0: Digital keypad (KPE-LE02) 1: RS485 serial communication or KPC-CC01 (optional) 2: External analog input (Pr.03-00) 3: External UP/DOWN terminal 4: Reserved 5: Reserved 6: CANopen communication 7: Digital keypad potentiometer	0
00-21	Source of the Operation Command (AUTO)	0: Digital keypad 1: External terminals. Keypad STOP disabled. 2: RS-485 serial communication. Keypad STOP disabled. 3: CANopen communication card	0

Parameter	Explanation	Settings	Factory Setting
00-22	Stop Method	0: Ramp to stop 1: Coast to stop	0
00-23	Control of Motor Direction	0: Enable forward/reverse 1: Reverse disable 2: Forward disable	0
00-24	Memory of Frequency Command	Read only	Read only
00-25	User Defined Characteristics	bit 0~3: user define on decimal place 0000b: no decimal place 0001b: one decimal place 0010b: two decimal place 0011b: three decimal place bit 4~15: user define on unit 000xh: Hz 001xh: rpm 002xh: % 003xh: kg 004xh: m/s 005xh: kW 006xh: HP 007xh: ppm 008xh: 1/m 009xh: kg/s 00Axh: kg/m 00Bxh: kg/h 00Cxh: lb/s 00Dxh: lb/m 00Exh: lb/h 00Fxh: ft/s 010xh: ft/m 011xh: m 012xh: ft 013xh: degC 014xh: degF 015xh: mbar 016xh: bar 017xh: Pa 018xh: kPa 019xh: mWG 01Axh: inWG 01Bxh: ftWG 01Cxh: psi 01Dxh: atm 01Exh: L/s 01Fxh: L/m 020xh: L/h 021xh: m3/s 022xh: m3/h 023xh: GPM 024xh: CFM xxxhx: Hz	0
00-26	Max. User Defined Value	0: Disable 0~65535 (when Pr.00-25 set to no decimal place) 0.0~6553.5 (when Pr.00-25 set to 1 decimal place) 0.0~655.35 (when Pr.00-25 set to 2 decimal place) 0.0~65.535 (when Pr.00-25 set to 3 decimal place)	0

Parameter	Explanation	Settings	Factory Setting
00-27	User Defined Value	Read only	Read Only
00-28	Reserved	-	-
00-29	LOCAL/REMOTE Selection	0: Standard HOA function 1: Switching Local/Remote, the drive stops 2: Switching Local/Remote, the drive runs as the REMOTE setting for frequency and operation status 3: Switching Local/Remote, the drive runs as the LOCAL setting for frequency and operation status 4: Switching Local/Remote, the drive runs as LOCAL setting when switch to Local and runs as REMOTE setting when switch to Remote for frequency and operation status.	0
00-30	Source of the Master Frequency Command (HAND)	0: Digital keypad (KPE-LE02) 1: RS-485 serial communication or KPC-CC01 (optional) 2: External analog input (Pr.03-00) 3: External UP/DOWN terminal 4: Reserved 5: Reserved 6: CANopen communication 7: Digital keypad potentiometer	1
00-31	Source of the Operation Command (HAND)	0: Digital keypad (KPE-LE02) 1: External terminals. Keypad STOP disabled. 2: RS-485 serial communication or KPC-CC01 (optional). Keypad STOP disabled. 3: CANopen communication card	2
00-32	Digital Keypad STOP Function	0: STOP key disable 1: STOP key enable	0
00-33 ~ 00-47	Reserved	-	-
00-48	Display Filter Time (Current)	0.001~65.535 sec.	0.100
00-49	Display Filter Time (Keypad)	0.001~65.535 sec.	0.100
00-50	Software Version (date)	Read only	#####

01 Basic Parameters

Parameter	Explanation	Settings	Factory Setting
01-00	Max. Operation Frequency	0.00~600.00Hz	60.00/ 50.00
01-01	Output Frequency of Motor 1	0.00~600.00Hz	60.00/ 50.00
01-02	Output Voltage of Motor 1	230V: 0.0V~255.0V 460V: 0.0V~510.0V	200.0 400.0
01-03	Mid-point Frequency 1 of Motor 1	0.00~600.00Hz	3.00
⚡ 01-04	Mid-point Voltage 1 of Motor 1	230V: 0.0V~240.0V 460V: 0.0V~480.0V	11.0 22.0
01-05	Mid-point Frequency 2 of Motor 1	0.00~600.00Hz	0.50
⚡ 01-06	Mid-point Voltage 2 of Motor 1	230V: 0.0V~240.0V 460V: 0.0V~480.0V	2.0 4.0
01-07	Min. Output Frequency of Motor 1	0.00~600.00Hz	0.00
⚡ 01-08	Min. Output Voltage of Motor 1	230V: 0.0V~240.0V 460V: 0.0V~480.0V	0.0 0.0
01-09	Start-Up Frequency	0.00~600.00Hz	0.50
⚡ 01-10	Output Frequency Upper Limit	0.00~600.00Hz	600.00
⚡ 01-11	Output Frequency Lower Limit	0.00~600.00Hz	0.00
⚡ 01-12	Accel. Time 1	Pr.01-45=0: 0.00~600.00 sec. Pr.01-45=1: 0.00~6000.0 sec.	10.00 10.0
⚡ 01-13	Decel Time 1	Pr.01-45=0: 0.00~600.00 sec. Pr.01-45=1: 0.00~6000.0 sec.	10.00 10.0
⚡ 01-14	Accel Time 2	Pr.01-45=0: 0.00~600.00 sec. Pr.01-45=1: 0.00~6000.0 sec.	10.00 10.0
⚡ 01-15	Decel Time 2	Pr.01-45=0: 0.00~600.00 sec. Pr.01-45=1: 0.00~6000.0 sec.	10.00 10.0
⚡ 01-16	Accel Time 3	Pr.01-45=0: 0.00~600.00 sec. Pr.01-45=1: 0.00~6000.0 sec.	10.00 10.0
⚡ 01-17	Decel Time 3	Pr.01-45=0: 0.00~600.00 sec. Pr.01-45=1: 0.00~6000.0 sec.	10.00 10.0
⚡ 01-18	Accel Time 4	Pr.01-45=0: 0.00~600.00 sec. Pr.01-45=1: 0.00~6000.0 sec.	10.00 10.0
⚡ 01-19	Decel Time 4	Pr.01-45=0: 0.00~600.00 sec. Pr.01-45=1: 0.00~6000.0 sec.	10.00 10.0
⚡ 01-20	JOG Acceleration Time	Pr.01-45=0: 0.00~600.00 sec. Pr.01-45=1: 0.00~6000.0 sec.	10.00 10.0
⚡ 01-21	JOG Deceleration Time	Pr.01-45=0: 0.00~600.00 sec. Pr.01-45=1: 0.00~6000.0 sec.	10.00 10.0
⚡ 01-22	JOG Frequency	0.00~600.00Hz	6.00
⚡ 01-23	1st/4th Accel/decel Frequency	0.00~600.00Hz	0.00
⚡ 01-24	S-curve Acceleration Begin Time 1	Pr.01-45=0: 0.00~25.00 sec. Pr.01-45=1: 0.0~250.0 sec.	0.20 0.2

Parameter	Explanation	Settings	Factory Setting
↗ 01-25	S-curve Acceleration Arrival Time 2	Pr.01-45=0: 0.00~25.00 sec. Pr.01-45=1: 0.0~250.0 sec.	0.20 0.2
↗ 01-26	S-curve Deceleration Begin Time 1	Pr.01-45=0: 0.00~25.00 sec. Pr.01-45=1: 0.0~250.0 sec.	0.20 0.2
↗ 01-27	S-curve Deceleration Arrival Time 2	Pr.01-45=0: 0.00~25.00 sec. Pr.01-45=1: 0.0~250.0 sec.	0.20 0.2
01-28	Skip Frequency 1 (upper limit)	0.00~600.00Hz	0.00
01-29	Skip Frequency 1 (lower limit)	0.00~600.00Hz	0.00
01-30	Skip Frequency 2 (upper limit)	0.00~600.00Hz	0.00
01-31	Skip Frequency 2 (lower limit)	0.00~600.00Hz	0.00
01-32	Skip Frequency 3 (upper limit)	0.00~600.00Hz	0.00
01-33	Skip Frequency 3 (lower limit)	0.00~600.00Hz	0.00
01-34	Zero-speed Mode	0: Output waiting 1: Zero-speed operation 2: Fmin (the 4 th output frequency)	0
01-35	Output Frequency of Motor 2	0.00~600.00Hz	60.00/ 50.00
01-36	Output Voltage of Motor 2	230V: 0.0V~255.0V 460V: 0.0V~510.0V	200.0 400.0
01-37	Mid-point Frequency 1 of Motor 2	0.00~600.00Hz	3.00
↗ 01-38	Mid-point Voltage 1 of Motor 2	230V: 0.0V~240.0V 460V: 0.0V~480.0V	11.0 22.0
01-39	Mid-point Frequency 2 of Motor 2	0.00~600.00Hz	0.50
↗ 01-40	Mid-point Voltage 2 of Motor 2	230V: 0.0V~240.0V 460V: 0.0V~480.0V	2.0 4.0
01-41	Min. Output Frequency of Motor 2	0.00~600.00Hz	0.00
↗ 01-42	Min. Output Voltage of Motor 2	230V: 0.0V~240.0V 460V: 0.0V~480.0V	0.0 0.0
01-43	V/f Curve Selection	0: V/f curve determined by Pr.01-00~Pr.01-08 1: Curve to the power of 1.5 2: Curve to the power of 2	0
↗ 01-44	Optimal Acceleration/Deceleration Setting	0: Linear accel. /decel. 1: Auto accel.; linear decel. 2: Linear accel.; auto decel. 3: Auto accel./decel. 4: Linear, stall prevention by auto accel./decel. (limit by Pr.01-12 to 01-21)	0
01-45	Time Unit for Accel. /Decel. and S Curve	0: Unit: 0.01 sec. 1: Unit: 0.1sec.	0
↗ 01-46	CANopen Quick Stop Time	Pr. 01-45=0: 0.00~600.00 sec. Pr. 01-45=1: 0.0~6000.0 sec.	1.00

02 Digital Input/Output Parameters

Parameter	Explanation	Settings	Factory Setting
02-00	2-wire/3-wire Operation Control	0: 2-wire mode, power on for operation control 1: 2-wire mode 2, power on for operation control 2: 3-wire, power on for operation control	0
02-01	Multi-function Input Command 1 (MI1)	0: No function	1
02-02	Multi-function Input Command 2 (MI2)	1: Multi-step speed command 1/multi-step position command 1	2
02-03	Multi-function Input Command 3 (MI3)	2: Multi-step speed command 2/multi-step position command 2	3
02-04	Multi-function Input Command 4 (MI4)	3: Multi-step speed command 3/multi-step position command 3	4
02-05	Multi-function Input Command 5 (MI5)	4: Multi-step speed command 4/multi-step position command 4	0
02-06	Multi-function Input Command 6 (MI6)	5: Reset	0
02-07	Multi-function Input Command 7 (MI7)	6: JOG command (By KPG-CC01 or external control)	0
02-08	Multi-function Input Command 8 (MI8)	7: Acceleration/deceleration speed inhibit	0
		8: The 1 st , 2 nd acceleration/deceleration time selection	0
		9: The 3 rd , 4 th acceleration/deceleration time selection	0
		10: EF Input (Pr.07-20)	0
		11: B.B input from external (Base Block)	
		12: Output stop	
		13: Cancel the setting of optimal accel. /decel. time	
		14: Switch between motor 1 and motor 2	
		15: Operation speed command from AVI	
		16: Operation speed command from ACI	
		17: Operation speed command from AUI	
		18: Emergency stop (Pr.07-20)	
		19: Digital up command	
		20: Digital down command	
		21: PID function disabled	
		22: Clear counter	
		23: Input the counter value (MI6)	
		24: FWD JOG command	
		25: REV JOG command	
		26: TQC/FOCmodel selection	
		27: ASR1/ASR2 selection	
		28: Emergency stop (EF1)	
		29: Signal confirmation for Y-connection	
		30: Signal confirmation for Δ-connection	
		31: High torque bias (Pr.11-30)	
		32: Middle torque bias (Pr.11-31)	
		33: Low torque bias (Pr.11-32)	
		34~37: Reserved	
		38: Disable EEPROM write function	
		39: Torque command direction	
		40: Force coast to stop	

Parameter	Explanation	Settings	Factory Setting
		41: HAND switch 42: AUTO switch 43~47: Reserved 48: Mechanical gear ratio switch 49: Drive enable 50: Master dEb action input 51: Selection for PLC mode bit0 52: Selection for PLC mode bit1 53: Trigger CANopen quick stop 54~55: Reserved 56: Local/Remote Selection	
↗ 02-09	UP/DOWN key mode	0: up/down by the accel. /decel. time 1: up/down constant speed (Pr.02-10)	0
↗ 02-10	Constant speed. The Accel. /Decel. Speed of the UP/DOWN Key	0.01~1.00Hz/ms	0.01
↗ 02-11	Digital Input Response Time	0.000~30.000 sec.	0.005
↗ 02-12	Digital Input Mode Selection	0000h~FFFFh (0: N.O.; 1: N.C.)	0000
↗ 02-13	Multi-function Output 1 RY1	0: No function 1: Operation Indication	11
↗ 02-14	Multi-function Output 2 RY2	2: Operation speed attained 3: Desired frequency attained 1 (Pr.02-22)	1
↗ 02-16	Multi-function Output 3 (MO1) (When Pr02-21 =0, this parameter is enabled.)	4: Desired frequency attained 2 (Pr.02-24) 5: Zero speed (Frequency command) 6: Zero speed, include STOP(Frequency command)	0
↗ 02-17	Multi-function Output 4 (MO2) (When Pr02-55 =0, this parameter is enabled.)	7: Over torque 1(Pr.06-06~06-08) 8: Over torque 2(Pr.06-09~06-11) 9: Drive is ready 10: Low voltage warning (LV) (Pr.06-00) 11: Malfunction indication 12: Mechanical brake release(Pr.02-32) 13: Overheat warning (Pr.06-15) 14: Software brake signal indication(Pr.07-00) 15: PID feedback error 16: Slip error (oSL) 17: Terminal count value attained, does not return to 0 (Pr.02-20) 18: Preliminary count value attained, returns to 0 (Pr.02-19) 19: Base Block 20: Warning output 21: Over voltage warning 22: Over-current stall prevention warning 23: Over-voltage stall prevention warning 24: Operation mode indication	0

Parameter	Explanation	Settings	Factory Setting
		25: Forward command 26: Reverse command 27: Output when current \geq Pr.02-33 (\geq 02-33) 28: Output when current \leq Pr.02-33 (\leq 02-33) 29: Output when frequency \geq Pr.02-34 (\geq 02-34) 30: Output when frequency \leq Pr.02-34 (\leq 02-34) 31: Y-connection for the motor coil 32: Δ -connection for the motor coil 33: Zero speed (actual output frequency) 34: Zero speed include stop(actual output frequency) 35: Error output selection 1(Pr.06-23) 36: Error output selection 2(Pr.06-24) 37: Error output selection 3(Pr.06-25) 38: Error output selection 4(Pr.06-26) 39: Reserved 40: Speed attained (including Stop) 41: Reserved 42: Crane function 43: Actual motor speed slower than Pr.02-47 44: Low current output (use with Pr.06-71~06-73) 45: Reserved 46: Master dEb warning output 47: Closed brake output 48: Reserved 49: Reserved 50: Output for CANopen control 51: Output for RS485 52~66: Reserved 67: Analog input signal level achieved	
02-15	Reserved	-	-
↗ 02-18	Multi-function output direction	0000h~FFFFh (0: N.O.; 1: N.C.)	0000
↗ 02-19	Terminal counting value attained (returns to 0)	0~65500	0
↗ 02-20	Preliminary counting value attained (not return to 0)	0~65500	0
↗ 02-21	Digital Output Gain (DFM)	0~106	1
↗ 02-22	Desired Frequency Attained 1	0.00~600.00Hz	60.00/ 50.00
↗ 02-23	The Width of the Desired Frequency Attained 1	0.00~600.00Hz	2.00
↗ 02-24	Desired Frequency Attained 2	0.00~600.00Hz	60.00/ 50.00
↗ 02-25	The Width of the Desired Frequency Attained 2	0.00~600.00Hz	2.00
02-26 ~ 02-31	Reserved	-	-

Parameter	Explanation	Settings	Factory Setting
02-32	Brake Delay Time	0.000~65.000 sec.	0.000
↗ 02-33	Output Current Level Setting for Multi-function External Terminals	0~100%	0
↗ 02-34	Output frequency setting for multi-function output terminal	0.00~600.00Hz (Motor speed when using PG Card)	0.00
↗ 02-35	External Operation Control Selection after Reset and Activate	0: Disable 1: Drive runs if run command exists after reset	0
02-36 ~ 02-46	Reserved	-	-
↗ 02-47	Zero-speed Level of Motor	0~65535 rpm	0
↗ 02-48	Max. Frequency of Resolution Switch	0.00~600.00Hz	60.00
↗ 02-49	Switch the delay time of Max. output frequency	0~65 sec.	0
↗ 02-50	Status of Multi-function Input Terminal	Monitor the status of multi-function input terminals	Read only
02-51	Status of Multi-function Output Terminal	Monitor the status of multi-function output terminals	Read only
02-52	Display External Output terminal occupied by PLC	Monitor the status of PLC input terminals	Read only
02-53	Display Analog Input Terminal occupied by PLC	Monitor the status of PLC output terminals	Read only
02-54	Display the Frequency Command Executed by External Terminal	Read only	Read only
↗ 02-55	Digital Output Gain (DFM2)	0~106	1

03 Analog Input/Output Parameters

	Parameter	Explanation	Settings	Factory Setting
↗	03-00	Analog Input Selection (AVI)	0: No function 1: Frequency command (torque limit under torque control mode)	1
↗	03-01	Analog Input Selection (ACI)	2: Torque command (torque limit under speed mode)	0
↗	03-02	Analog Input Selection (AUI)	3: Torque compensation command 4: PID target value 5: PID feedback signal 6: PTC thermistor input value 7: Positive torque limit 8: Negative torque limit 9: Regenerative torque limit 10: Positive/negative torque limit	0
↗	03-03	Analog Input Bias (AVI)	-100.0~100.0%	0
↗	03-04	Analog Input Bias (ACI)	-100.0~100.0%	0
↗	03-05	Analog Positive Voltage Input Bias (AUI)	-100.0~100.0%	0
	03-06	Reserved	-	-
↗	03-07	Positive/negative Bias Mode (AVI)	0: No bias 1: Lower than or equal to bias	0
↗	03-08	Positive/negative Bias Mode (ACI)	2: Greater than or equal to bias 3: The absolute value of the bias voltage while serving as the center	
↗	03-09	Positive/negative Bias Mode (AUI)	4: Serve bias as the center	
	03-10	Analog Frequency Command for Reverse Run	0: Negative frequency is not valid. Forward and reverse run is controlled by digital keypad or external terminal. 1: Negative frequency is valid. Positive frequency = forward run; negative frequency = reverse run. Direction can not be switched by digital keypad or external terminal control.	0
↗	03-11	Analog Input Gain (AVI)	-500.0~500.0%	100.0
↗	03-12	Analog Input Gain (ACI)	-500.0~500.0%	100.0
↗	03-13	Analog Positive Input Gain (AUI)	-500.0~500.0%	100.0
↗	03-14	Analog Negative Input Gain (AUI)	-500.0~500.0%	100.0
↗	03-15	Analog Input Filter Time (AVI)	0.00~20.00 sec.	0.01
↗	03-16	Analog Input Filter Time (ACI)	0.00~20.00 sec.	0.01
↗	03-17	Analog Input Filter Time (AUI)	0.00~20.00 sec.	0.01
↗	03-18	Addition Function of the Analog Input	0: Disable (AVI, ACI, AUI) 1: Enable	0

Parameter	Explanation	Settings	Factory Setting
03-19	ACI Signal Loss	0: Disable 1: Continue operation at the last frequency 2: Decelerate to 0Hz 3: Stop immediately and display ACE	0
03-20	Multi-function Output 1 (AFM1)	0: Output frequency (Hz) 1: Frequency command (Hz)	0
03-23	Multi-function Output 2 (AFM2)	2: Motor speed (Hz) 3: Output current (rms) 4: Output voltage 5: DC Bus voltage 6: Power factor 7: Power 8: Output torque 9: AVI 10: ACI 11: AUI 12: Iq current 13: Iq feedback value 14: Id current 15: Id feedback value 16: Vq-axis voltage 17: Vd-axis voltage 18: Torque command 19: Reserved 20: CANopen analog output 21: RS485 analog output 22: Reserved 23: Constant voltage/current output	0
03-21	Gain of Analog Output 1 (AFM1)	0~500.0%	100.0
03-22	Analog Output 1 when in REV Direction (AFM1)	0: Absolute output voltage 1: Reverse output 0V; Positive output 0-10V 2: Reverse output 5-0V; Positive output 5-10V	0
03-24	Gain of Analog Output 2 (AFM2)	0~500.0%	100.0
03-25	Analog Output 2 when in REV Direction (AFM2)	0: Absolute output voltage 1: Output 0V in REV direction; output 0-10V in FWD direction 2: Output 5-0V in REV direction; output 5-10V in FWD direction	0
03-26	Reserved	-	-
03-27	Reserved	-	-
03-28	AVI Selection	0: 0-10V 1: 0-20mA 2: 4-20mA	0

Parameter	Explanation	Settings	Factory Setting
03-29	ACI Selection	0: 4-20mA 1: 0-10V 2: 0-20mA	0
03-30	Status of PLC Output Terminal	Monitor the status of PLC output terminals	Read only
03-31	AFM2 0-20mA Output Selection	0: 0-20mA Output 1: 4-20mA Output	0
03-32	AFM1 DC output setting level	0.00~100.00%	0.00
03-33	AFM2 DC Output Setting Level	0.00~100.00%	0.00
03-34 ~ 03-38	Reserved	-	-
03-39	Keypad Potentiometer Selection	0: No function 1: Frequency command	0
03-40	Keypad Potentiometer Input Bias	-100.0~100.0%	0.0
03-41	Keypad Potentiometer Positive/negative Bias Mode	0: No bias 1: Lower than or equal to bias 2: Greater than or equal to bias 3: The absolute value of the bias voltage while serving as the center 4: Serve bias as the center	0
03-42	Keypad Potentiometer Input Gain	-500.0~500.0%	100.0
03-43	Keypad Potentiometer Analog Input Filter Time	0~2.00 sec.	0.01
03-44	MO by AI Level	0: AVI 1: ACI 2: AUI	0
03-45	AI Upper Level	-100.00%~100.00%	50.00
03-46	AI Lower Level	-100.00%~100.00%	10.00
03-47 ~ 03-49	Reserved	-	-
03-50	Analog Input Curve Selection	0: Regular Curve 1: 3 point curve of AVI 2: 3 point curve of ACI 3: 3 point curve of AVI & ACI 4: 3 point curve of AUI 5: 3 point curve of AVI & AUI 6: 3 point curve of ACI & AUI 7: 3 point curve of AVI & ACI & AUI	0
03-51	AVI Low Point	Pr.03-28=0, 0.00~10.00V Pr.03-28≠0, 0.00~20.00mA	0.00
03-52	AVI Proportional Low Point	0.00~100.00%	0.00

	Parameter	Explanation	Settings	Factory Setting
↗	03-53	AVI Mid Point	Pr.03-28=0, 0.00~10.00V Pr.03-28≠0, 0.00~20.00mA	5.00
↗	03-54	AVI Proportional Mid Point	0.00~100.00%	50.00
↗	03-55	AVI High Point	Pr.03-28=0, 0.00~10.00V Pr.03-28≠0, 0.00~20.00mA	10.00
↗	03-56	AVI Proportional High Point	0.00~100.00%	100.00
↗	03-57	ACI Low Point	Pr.03-29=1, 0.00~10.00V Pr.03-29≠1, 0.00~20.00mA	4.00
↗	03-58	ACI Proportional Low Point	0.00~100.00%	0.00
↗	03-59	ACI Mid Point	Pr.03-29=1, 0.00~10.00V Pr.03-29≠1, 0.00~20.00mA	12.00
↗	03-60	ACI Proportional Mid Point	0.00~100.00%	50.00
↗	03-61	ACI High Point	Pr.03-29=1, 0.00~10.00V Pr.03-29≠1, 0.00~20.00mA	20.00
↗	03-62	ACI Proportional High Point	0.00~100.00%	100.00
↗	03-63	Positive AUI Voltage Low Point	0.00~10.00V	0.00
↗	03-64	Positive AUI Voltage Proportional Low Point	0.00~100.00%	0.00
↗	03-65	Positive AUI Voltage Mid Point	0.00~10.00V	5.00
↗	03-66	Positive AUI Voltage Proportional Mid Point	0.00~100.00%	50.00
↗	03-67	Positive AUI Voltage High Point	0.00~10.00V	10.00
↗	03-68	Positive AUI Voltage Proportional High Point	0.00~100.00%	100.00
↗	03-69	Negative AUI Voltage Low Point	0.00~ -10.00V	0.00
↗	03-70	Negative AUI Voltage Proportional Low Point	0.00~ -100.00%	0.00
↗	03-71	Negative AUI Voltage Mid Point	0.00~ -10.00V	-5.00
↗	03-72	Negative AUI Voltage Proportional Mid Point	0.00~ -100.00%	-50.00
↗	03-73	Negative AUI Voltage High Point	0.00~ -10.00V	-10.00
↗	03-74	Negative AUI Voltage Proportional High Point	0.00~ -100.00%	-100.00

04 Multi-step Speed Parameters

	Parameter	Explanation	Settings	Factory Setting
↗	04-00	1st Step Speed Frequency	0.00~600.00Hz	0
↗	04-01	2nd Step Speed Frequency	0.00~600.00Hz	0
↗	04-02	3rd Step Speed Frequency	0.00~600.00Hz	0
↗	04-03	4th Step Speed Frequency	0.00~600.00Hz	0
↗	04-04	5th Step Speed Frequency	0.00~600.00Hz	0
↗	04-05	6th Step Speed Frequency	0.00~600.00Hz	0
↗	04-06	7th Step Speed Frequency	0.00~600.00Hz	0
↗	04-07	8th Step Speed Frequency	0.00~600.00Hz	0
↗	04-08	9th Step Speed Frequency	0.00~600.00Hz	0
↗	04-09	10th Step Speed Frequency	0.00~600.00Hz	0
↗	04-10	11th Step Speed Frequency	0.00~600.00Hz	0
↗	04-11	12th Step Speed Frequency	0.00~600.00Hz	0
↗	04-12	13th Step Speed Frequency	0.00~600.00Hz	0
↗	04-13	14th Step Speed Frequency	0.00~600.00Hz	0
↗	04-14	15th Step Speed Frequency	0.00~600.00Hz	0
	04-15 ~ 04-69	Reserved	-	-
↗	04-50 ~ 04-69	PLC Buffer 0~19	0~65535	0

05 Motor Parameters

Parameter	Explanation	Settings	Factory Setting
05-00	Motor Auto Tuning	0: No function 1: Rolling test for induction motor(IM) (Rs, Rr, Lm, Lx, no-load current) 2: Static test for induction motor(IM) 3: Reserved 4: Rolling test for PM motor magnetic pole 5: Rolling test for PM motor 6: Rolling test for IM motor flux curve 7~11: Reserved 12: FOC Sensorless inertia estimation 13: High frequency and blocked rotor test for PM motor	0
05-01	Full-load Current of Induction Motor 1(A)	10~120% of drive's rated current	###
05-02	Rated Power of Induction Motor 1(kW)	0~655.35kW	###
05-03	Rated Speed of Induction Motor 1 (rpm)	0~65535 1710 (60Hz 4poles) ; 1410 (50Hz 4 poles)	1710
05-04	Pole Number of Induction Motor 1	2~20	4
05-05	No-load Current of Induction Motor 1 (A)	0~ Pr.05-01 factory setting	###
05-06	Stator Resistance (Rs) of Induction Motor 1	0~65.535mΩ	0
05-07	Rotor Resistance (Rr) of Induction Motor 1	0~65.535mΩ	0
05-08	Magnetizing Inductance (Lm) of Induction Motor 1	0~6553.5mH	0
05-09	Stator Inductance (Lx) of Induction Motor 1	0~6553.5mH	0
05-10 ~ 05-12	Reserved	-	-
05-13	Full-load Current of Induction Motor 2 (A)	10~120%	###
05-14	Rated Power of Induction Motor 2 (kW)	0~655.35kW	###
05-15	Rated Speed of Induction Motor 2 (rpm)	0~65535 1710(60Hz 4 poles) ; 1410(50Hz 4 poles)	1710
05-16	Pole Number of Induction Motor 2	2~20	4
05-17	No-load Current of Induction Motor 2 (A)	0~ Pr.05-01 factory setting	###
05-18	Stator Resistance (Rs) of Induction Motor 2	0~65.535mΩ	0
05-19	Rotor Resistance (Rr) of Induction Motor 2	0~65.535mΩ	0

Parameter	Explanation	Settings	Factory Setting
05-20	Magnetizing Inductance (Lm) of Induction Motor 2	0~6553.5mH	0
05-21	Stator Inductance (Lx) of Induction Motor 2	0~6553.5mH	0
05-22	Induction Motor 1/ 2 Selection	1: motor 1 2: motor 2	1
↗ 05-23	Frequency for Y-connection/ Δ -connection Switch of Induction Motor	0.00~600.00Hz	60.00
05-24	Y-connection/ Δ -connection Switch of Induction Motor	0: Disable 1: Enable	0
↗ 05-25	Delay Time for Y-connection/ Δ -connection Switch of Induction Motor	0.000~60.000 sec.	0.200
05-26	Accumulative Watt-second of Motor in Low Word (W-sec)	Read only	##
05-27	Accumulative Watt-second of Motor in High Word (W-sec)	Read only	##
05-28	Accumulative Watt-hour of Motor (W-Hour)	Read only	##
05-29	Accumulative Watt-hour of Motor in Low Word (KW-Hour)	Read only	##
05-30	Accumulative Watt-hour of Motor in High Word (KW-Hour)	Read only	##
05-31	Accumulative Motor Operation Time (Min)	00~1439	0
05-32	Accumulative Motor Operation Time (day)	00~65535	0
05-33	Induction Motor and Permanent Magnet Motor Selection	0: Induction Motor 1: Permanent Magnet Motor	0
05-34	Full-load current of Permanent Magnet Motor	0.00~655.35Amps	0.00
05-35	Rated Power of Permanent Magnet Motor	0.00~655.35kW	0.00
05-36	Rated speed of Permanent Magnet Motor	0~65535rpm	2000
05-37	Pole number of Permanent Magnet Motor	0~65535	10
05-38	Inertia of Permanent Magnet Motor	0.0~6553.5 kg.cm ²	0.0

Parameter	Explanation	Settings	Factory Setting
05-39	Stator Resistance of PM Motor	0.000~65.535Ω	0.000
05-40	Permanent Magnet Motor Ld	0.00~655.35mH	0.000
05-41	Permanent Magnet Motor Lq	0.00~655.35mH	0.000
05-42	PG Offset angle of PM Motor	0.0~360.0°	0.0
05-43	Ke parameter of PM Motor	0~65535 (Unit: V/1000rpm)	0

06 Protection Parameters

	Parameter	Explanation	Settings	Factory Setting
↗	06-00	Low Voltage Level	230V: 150.0~220.0Vdc 460V: 300.0~440.0Vdc	180.0 360.0
↗	06-01	Over-voltage Stall Prevention	0: Disabled 230V: 0.0~450.0Vdc 460V: 0.0~900.0Vdc	380.0 760.0
↗	06-02	Selection for Over-voltage Stall Prevention	0: Traditional over-voltage stall prevention 1: Smart over-voltage prevention	0
↗	06-03	Over-current Stall Prevention during Acceleration	Normal Load: 0~160% (100%: drive's rated current) Heavy Load: 0~180% (100%: drive's rated current)	120 150
↗	06-04	Over-current Stall Prevention during Operation	Normal Load: 0~160% (100%: drive's rated current) Heavy Load: 0~180% (100%: drive's rated current)	120 150
↗	06-05	Accel. /Decel. Time Selection of Stall Prevention at Constant Speed	0: by current accel/decel time 1: by the 1st accel/decel time 2: by the 2nd accel/decel time 3: by the 3rd accel/decel time 4: by the 4th accel/decel time 5: by auto accel/decel	0
↗	06-06	Over-torque Detection Selection (OT1)	0: No function 1: Over-torque detection during constant speed operation, continue to operate after detection 2: Over-torque detection during constant speed operation, stop operation after detection 3: Over-torque detection during operation, continue to operate after detection 4: Over-torque detection during operation, stop operation after detection	0
↗	06-07	Over-torque Detection Level (OT1)	10~250% (100%: drive's rated current)	120
↗	06-08	Over-torque Detection Time (OT1)	0.0~60.0 sec.	0.1
↗	06-09	Over-torque Detection Selection (OT2)	0: No function 1: Over-torque detection during constant speed operation, continue to operate after detection 2: Over-torque detection during constant speed operation, stop operation after detection 3: Over-torque detection during operation, continue to operation after detection 4: Over-torque detection during operation, stop operation after detection	0
↗	06-10	Over-torque Detection Level (OT2)	10~250% (100%: drive's rated current)	120
↗	06-11	Over-torque Detection Time (OT2)	0.1~60.0 sec.	0.1

Parameter	Explanation	Settings	Factory Setting
06-12	Current Limit	0~250% (100%: drive's rated current)	150
06-13	Electronic Thermal Relay Selection (Motor 1)	0: Inverter motor 1: Standard motor 2: Disable	2
06-14	Electronic Thermal Characteristic for Motor 1	30.0~600.0 sec.	60.0
06-15	Heat Sink Over-heat (OH) Warning	0.0~110.0°C	100.0
06-16	Stall Prevention Limit Level	0~100% (Pr.06-03, Pr.06-04)	50
06-17	Present Fault Record	0: No fault record	0
06-18	Second Most Recent Fault Record	1: Over-current during acceleration (ocA) 2: Over-current during deceleration (ocd)	0
06-19	Third Most Recent Fault Record	3: Over-current during constant speed(ocn) 4: Ground fault (GFF)	0
06-20	Fourth Most Recent Fault Record	5: IGBT short-circuit (occ) 6: Over-current at stop (ocS)	0
06-21	Fifth Most Recent Fault Record	7: Over-voltage during acceleration (ovA) 8: Over-voltage during deceleration (ovd)	0
06-22	Sixth Most Recent Fault Record	9: Over-voltage during constant speed (ovn) 10: Over-voltage at stop (ovS) 11: Low-voltage during acceleration (LvA) 12: Low-voltage during deceleration (Lvd) 13: Low-voltage during constant speed (Lvn) 14: Stop mid-low voltage (LvS) 15: Phase loss protection (OrP) 16: IGBT over-heat (oH1) 17: Capacitance over-heat (oH2) 18: tH1o (TH1 open: IGBT over-heat protection error) 19: tH2o (TH2 open: capacitance over-heat protection error) 20: Reserved 21: Drive over-load (oL) 22: Electronics thermal relay 1 (EoL1) 23: Electronics thermal relay 2 (EoL2) 24: Motor overheat (oH3) (PTC) 25: Reserved 26: Over-torque 1 (ot1) 27: Over-torque 2 (ot2) 28: Low current (uC) 29: Home limit error (LMIT) 30: Memory write-in error (cF1) 31: Memory read-out error (cF2) 32: Reserved 33: U-phase current detection error (cd1) 34: V-phase current detection error (cd2)	0

Parameter	Explanation	Settings	Factory Setting
		35: W-phase current detection error (cd3) 36: Clamp current detection error (Hd0) 37: Over-current detection error (Hd1) 38: Over-voltage detection error (Hd2) 39: Ground current detection error (Hd3) 40: Auto tuning error (AUE) 41: PID feedback loss (AFE) 42: PG feedback error (PGF1) 43: PG feedback loss (PGF2) 44: PG feedback stall (PGF3) 45: PG slip error (PGF4) 46: Reserved 47: Reserved 48: Analog current input loss (ACE) 49: External fault input (EF) 50: Emergency stop (EF1) 51: External Base Block (bb) 52: Password error (PcodE) 53: SW Code Error 54: Communication error (CE1) 55: Communication error (CE2) 56: Communication error (CE3) 57: Communication error (CE4) 58: Communication Time-out (CE10) 59: PU Time-out (CP10) 60: Reserved 61: Y-connection/ Δ -connection switch error (ydc) 62: Decel. Energy Backup Error (dEb) 63: Slip error (oSL) 64: Reserved 65: Reserved 66: Unknow Over Amp 67: Unknow Over Vol 68: Sensorless estimated speed have wrong direction 69: Sensorless estimated speed is over speed 70: Sensorless estimated speed deviated 71~72: Reserved 73: External safety gate S1 74~78: Reserved 79: U phase over current (Uocc) 80: V phase over current (Vocc) 81: W phase over current (Wocc) 82: U phase output phase loss (OPHL) 83: V phase output phase loss (OPHL) 84: W phase output phase loss (OPHL) 85~100: Reserved 101: CANopen software disconnect1 (CGdE) 102: CAN open software disconnect2 (CHbE)	

Parameter	Explanation	Settings	Factory Setting
		103: CANopen synchronous error (CSYE) 104: CANopen hardware disconnect (CbFE) 105: CANopen index setting error (CIdE) 106: CANopen slave station number setting error (CAdE) 107: CANopen index setting exceed limit (CFrE) 108~110: Reserved 111: Internal communication overtime error (InrCOM)	
✓ 06-23	Fault Output Option 1	0~65535 (refer to bit table for fault code)	0
✓ 06-24	Fault Output Option 2	0~65535 (refer to bit table for fault code)	0
✓ 06-25	Fault Output Option 3	0~65535 (refer to bit table for fault code)	0
✓ 06-26	Fault Output Option 4	0~65535 (refer to bit table for fault code)	0
✓ 06-27	Electronic Thermal Relay Selection 2 (Motor 2)	0: Inverter motor 1: Standard motor 2: Disable	2
✓ 06-28	Electronic Thermal Characteristic for Motor 2	30.0~600.0 sec	60.0
✓ 06-29	PTC Detection Selection	0: Warn and keep operation 1: Warn and ramp to stop 2: Warn and coast to stop 3: No warning	0
✓ 06-30	PTC Level	0.0~100.0%	50.0
06-31	Frequency Command for Malfunction	0.00~655.35 Hz	Read only
06-32	Output Frequency at Malfunction	0.00~655.35 Hz	Read only
06-33	Output Voltage at Malfunction	0.0~6553.5 V	Read only
06-34	DC Voltage at Malfunction	0.0~6553.5 V	Read only
06-35	Output Current at Malfunction	0.00~655.35 Amp	Read only
06-36	IGBT Temperature at Malfunction	-3276.7~3276.7°C	Read only
06-37	Capacitance Temperature at Malfunction	-3276.7~3276.7°C	Read only
06-38	Motor Speed in rpm at Malfunction	-32767~32767	Read only
06-39	Torque Command at Malfunction	-32767~32767	Read only
06-40	Status of Multi-function Input Terminal at Malfunction	0000h~FFFFh	Read only
06-41	Status of Multi-function Output Terminal at Malfunction	0000h~FFFFh	Read only

Parameter	Explanation	Settings	Factory Setting
06-42	Drive Status at Malfunction	0000h~FFFFh	Read only
06-43	Reserved	-	-
06-44	Reserved	-	-
⚡ 06-45	Treatment to Output Phase Loss Detection (OPHL)	0: Warn and keep operation 1: Warn and ramp to stop 2: Warn and coast to stop 3: No warning	3
⚡ 06-46	Deceleration Time of Output Phase Loss	0.000~65.535 sec.	0.500
⚡ 06-47	Current Bandwidth	0.00~655.35%	1.00
⚡ 06-48	DC Brake Time of Output Phase Loss	0.000~65.535 sec.	0.000
06-49	Reserved	-	-
⚡ 06-50	Time for Input Phase Loss Detection	0.00~600.00 sec.	0.20
06-51	Reserved	-	-
⚡ 06-52	Ripple of Input Phase Loss	230V model: 0.0~160.0 Vdc 460V model: 0.0~320.0 Vdc	30.0 /60.0
⚡ 06-53	Treatment for the detected Input Phase Loss (OrP)	0: warn and ramp to stop 1: warn and coast to stop	0
06-54	Reserved	-	-
⚡ 06-55	Derating Protection	0: constant rated current and limit carrier wave by load current and temperature 1: constant carrier frequency and limit load current by setting carrier wave 2: constant rated current(same as setting 0), but close current limit	0
06-56 ~ 06-59	Reserved	-	-
⚡ 06-60	Software Detection GFF Current Level	0.0~6553.5 %	60.0
⚡ 06-61	Software Detection GFF Filter Time	0.0~6553.5 sec.	0.10
⚡ 06-62	Disable Level of dEb	230V series: 0.0~220.0 Vdc 460V series: 0.0~440.0 Vdc	180.0 /360.0
06-63	Fault Record 1 (Day)	0~65535 days	Read only
06-64	Fault Record 1 (Min.)	0~1439 min.	Read only
06-65	Fault Record 2 (Day)	0~65535 days	Read only
06-66	Fault Record 2 (Min.)	0~1439 min.	Read only

Parameter	Explanation	Settings	Factory Setting
06-67	Fault Record 3 (Day)	0~65535 days	Read only
06-68	Fault Record 3 (Min.)	0~1439 min.	Read only
06-69	Fault Record 4 (Day)	0~65535 days	Read only
06-70	Fault Record 4 (Min.)	0~1439 min.	Read only
↗ 06-71	Low Current Setting Level	0.0~100.0%	0.0
↗ 06-72	Low Current Detection Time	0.00 ~ 60.00 sec.	0.00
↗ 06-73	Treatment for low current	0 : No function 1 : Warn and coast to stop 2 : Warn and ramp to stop by 2nd deceleration time 3 : Warn and operation continue	0

07 Special Parameters

Parameter	Explanation	Settings	Factory Setting
07-00	Software Brake Level	230V: 350.0~450.0Vdc 460V: 700.0~900.0Vdc	380.0 760.0
07-01	DC Brake Current Level	0~100%	0
07-02	DC Brake Time at Start-up	0.0~60.0 sec.	0.0
07-03	DC Brake Time at Stop	0.0~60.0 sec.	0.0
07-04	Startup Frequency for DC Brake	0.00~600.00Hz	0.00
07-05	Reserved	-	-
07-06	Restart after Momentary Power Loss	0: Stop operation 1: Speed search for last frequency command 2: Speed search for minimum output frequency	0
07-07	Maximum Power Loss Duration	0.1~20.0 sec.	2.0
07-08	Base Block Time	0.1~5.0 sec.	0.5
07-09	Current Limit for Speed Search	20~200%	50
07-10	Treatment to Reboots After Fault	0: Stop operation 1: Speed search starts with current speed 2: Speed search starts with minimum output frequency	0
07-11	Auto Restart After Fault	0~10	0
07-12	Speed Search during Start-up	0: Disable 1: Speed search for maximum output frequency 2: Speed search for start-up motor frequency 3: Speed search for minimum output frequency	0
07-13	Decel. Time to Momentary Power Loss	0: Disable 1: 1st decel. time 2: 2nd decel. time 3: 3rd decel. time 4: 4th decel. time 5: current decel. time 6: Auto decel. time	0
07-14	dEb Return Time	0.0~25.0 sec.	0.0
07-15	Dwell Time at Accel.	0.00 ~ 600.00 sec.	0.00
07-16	Dwell Frequency at Accel.	0.00 ~ 600.00Hz	0.00
07-17	Dwell Time at Decel.	0.00 ~ 600.00 sec.	0.00
07-18	Dwell Frequency at Decel.	0.00 ~ 600.00Hz	0.00
07-19	Fan Cooling Control	0: Fan always ON 1: 1 minute after the AC motor drive stops, fan will be OFF 2: When the AC motor drive runs, the fan is ON. When the AC motor drive stops, the fan is OFF	0

Parameter	Explanation	Settings	Factory Setting
		3: Fan turns ON when preliminary heat sink temperature (around 60°C) is attained. 4: Fan always OFF	
07-20	Emergency Stop (EF) & Force to Stop Selection	0: Coast stop 1: By deceleration Time 1 2: By deceleration Time 2 3: By deceleration Time 3 4: By deceleration Time 4 5: System Deceleration 6: Automatic Deceleration	0
07-21	Auto Energy-saving Operation	0: Disable 1: Enable	0
07-22	Energy-saving Gain	10~1000%	100
07-23	Auto Voltage Regulation(AVR) Function	0: Enable AVR 1: Disable AVR 2: Disable AVR during deceleration	0
07-24	Filter Time of Torque Command (V/F and SVC control mode)	0.001~10.000 sec.	0.050
07-25	Filter Time of Slip Compensation (V/F and SVC control mode)	0.001~10.000 sec.	0.100
07-26	Torque Compensation Gain (V/F and SVC control mode)	0~10	0
07-27	Slip Compensation Gain (V/F and SVC control mode)	0.00~10.00	0.00
07-28	Reserved	-	-
07-29	Slip Deviation Level	0.0~100.0% 0: No detection	0
07-30	Detection Time of Slip Deviation	0.0~10.0 sec.	1.0
07-31	Over Slip Treatment	0: Warn and keep operation 1: Warn and ramp to stop 2: Warn and coast to stop 3: No warning	0
07-32	Motor Hunting Gain	0~10000	1000
07-33	Auto Reset Time for Restart after Fault	0.0~6000.0 sec.	60.0
07-34 ~ 07-37	Reserved	-	-
07-38	Speed Tracking on Frequency Derivative	1~500	1

08 High-function PID Parameters

Parameter	Explanation	Settings	Factory Setting
08-00	Input Terminal for PID Feedback	0: No function 1: Negative PID feedback: input from external terminal AVI (Pr.03-00) 2: Negative PID feedback from PG card (Pr.10-15, skip direction) 3: Negative PID feedback from PG card (Pr.10-15) 4: Positive PID feedback from external terminal AVI (Pr.03-00) 5: Positive PID feedback from PG card (Pr.10-15, skip direction) 6: Positive PID feedback from PG card (Pr.10-15)	0
08-01	Proportional Gain (P)	0.0~500.0%	1.0
08-02	Integral Time (I)	0.00~100.00 sec.	1.00
08-03	Derivative Control (D)	0.00~1.00 sec.	0.00
08-04	Upper Limit of Integral Control	0.0~100.0%	100.0
08-05	PID Output Frequency Limit	0.0~110.0%	100.0
08-06	Reserved	-	-
08-07	PID Delay Time	0.0~2.5 sec.	0.0
08-08	Feedback Signal Detection Time	0.0~3600.0 sec.	0.0
08-09	Feedback Signal Fault Treatment	0: Warn and keep operation 1: Warn and ramp to stop 2: Warn and coast to stop 3: Warn and operate at last frequency	0
08-10	Sleep Frequency	Pr.08-18=0: 0.00 ~ 600.00Hz Pr.08-18=1: 0.00~200.00%	0.00
08-11	Wake-up Frequency	Pr.08-18=0: 0.00 ~ 600.00Hz Pr.08-18=1: 0.00~200.00%	0.00
08-12	Sleep Time	0.0 ~ 6000.0 sec.	0.0
08-13	PID Deviation Level	1.0 ~ 50.0%	10.0
08-14	PID Deviation Time	0.1~300.0 sec.	5.0
08-15	Filter Time for PID Feedback	0.1~300.0 sec.	5.0
08-16	PID Compensation Selection	0: Parameter setting 1: Analog input	0
08-17	PID Compensation	-100.0~+100.0%	0
08-18	Setting of Sleep Mode Function	0: Follow PID output command 1: Follow PID feedback signal	0
08-19	Wake-up Integral Limit	0.0~200.0%	50.0

Parameter	Explanation	Settings	Factory Setting
08-20	PID Mode Selection	0: Serial connection 1: Parallel connection	0
08-21	Enable PID to Change Operation Direction	0: Operation direction can not be changed 1: Operation direction can be changed	0

09 Communication Parameters

	Parameter	Explanation	Settings	Factory Setting
✓	09-00	COM1 Communication Address	1~254	1
✓	09-01	COM1 Transmission Speed	4.8~115.2Kbps	9.6
✓	09-02	COM1 Transmission Fault Treatment	0: Warn and continue operation 1: Warn and ramp to stop 2: Warn and coast to stop 3: No warning and continue operation	3
✓	09-03	COM1 Time-out Detection	0.0~100.0 sec.	0.0
✓	09-04	COM1 Communication Protocol	0: 7N1 (ASCII) 1: 7N2 (ASCII) 2: 7E1 (ASCII) 3: 7O1 (ASCII) 4: 7E2 (ASCII) 5: 7O2 (ASCII) 6: 8N1 (ASCII) 7: 8N2 (ASCII) 8: 8E1 (ASCII) 9: 8O1 (ASCII) 10: 8E2 (ASCII) 11: 8O2 (ASCII) 12: 8N1 (RTU) 13: 8N2 (RTU) 14: 8E1 (RTU) 15: 8O1 (RTU) 16: 8E2 (RTU) 17: 8O2 (RTU)	1
	09-05 ~ 09-08	Reserved	-	-
✓	09-09	Response Delay Time	0.0~200.0ms	2.0
✓	09-10	Main Frequency of the Communication	0.00~600.00Hz	60.00
✓	09-11	Block Transfer 1	0~65535	0
✓	09-12	Block Transfer 2	0~65535	0
✓	09-13	Block Transfer 3	0~65535	0
✓	09-14	Block Transfer 4	0~65535	0
✓	09-15	Block Transfer 5	0~65535	0
✓	09-16	Block Transfer 6	0~65535	0
✓	09-17	Block Transfer 7	0~65535	0
✓	09-18	Block Transfer 8	0~65535	0
✓	09-19	Block Transfer 9	0~65535	0
✓	09-20	Block Transfer 10	0~65535	0

	Parameter	Explanation	Settings	Factory Setting
✓	09-21	Block Transfer 11	0~65535	0
✓	09-22	Block Transfer 12	0~65535	0
✓	09-23	Block Transfer 13	0~65535	0
✓	09-24	Block Transfer 14	0~65535	0
✓	09-25	Block Transfer 15	0~65535	0
✓	09-26	Block Transfer 16	0~65535	0
	09-27 ~ 09-29	Reserved	-	-
	09-30	Communication Decoding Method	0: Decoding Method 1 (20xx) 1: Decoding Method 2 (60xx)	1
	09-31	Internal Communication Protocol	0: Modbus 485	0
	09-32 ~ 09-33	Reserved	-	-
	09-34	PLC PID	0~65535	0
	09-35	PLC Address	1~254	2
	09-36	CANopen Slave Address	0: Disable 1~127	0
	09-37	CANopen Speed	0: 1M 1: 500k 2: 250k 3: 125k 4: 100k (Delta only) 5: 50k	0
✓	09-38	CANopen Frequency Gain	0.00 ~ 2.00	1.00
	09-39	CANopen Warning Record	bit 0: CANopen Guarding Time out bit 1: CANopen Heartbeat Time out bit 2: CANopen SYNC Time out bit 3: CANopen SDO Time out bit 4: CANopen SDO buffer overflow bit 5: Can Bus Off bit 6: Error protocol of CANopen	0
	09-40	CANopen Decoding Method	0: Delta defined decoding method 1: CANopen DS402 Standard	1
	09-41	CANopen Communication Status	0: Node Reset State 1: Com Reset State 2: Boot up State 3: Pre Operation State 4: Operation State 5: Stop State	Read Only

Parameter	Explanation	Settings	Factory Setting
09-42	CANopen Control Status	0: Not ready for use state 1: Inhibit start state 2: Ready to switch on state 3: Switched on state 4: Enable operation state 7: Quick Stop Active state 13: Err Reaction Activation state 14: Error state	Read Only
09-43	Reset CANopen Index	bit0: reset address 20XX to 0. bit1: reset address 264X to 0 bit2: reset address 26AX to 0 bit3: reset address 60XX to 0	65535
09-44	Reserved	-	-
09-45	CANopen Master Function	0: Disable 1: Enable	0
09-46	CANopen Master Address	1~127	100

10 Speed Feedback Control Parameters



NOTE IM: Induction Motor; PM: Permanent Magnet Motor

Parameter	Explanation	Settings	Factory Setting
10-00	Reserved	-	-
10-01	Encoder Pulse	1~20000	600
10-02	Encoder Input Type Setting (MI7=A, MI8=B)	0: Disable 1: Phase A leads in a forward run command and phase B leads in a reverse run command 2: Phase B leads in a forward run command and phase A leads in a reverse run command 3: Phase A is a pulse input and phase B is a direction input. (low input=reverse direction, high input=forward direction) 4: Phase A is a pulse input and phase B is a direction input. (low input=forward direction, high input=reverse direction) 5: Single-phase input	0
10-03	Reserved	-	-
✓ 10-04	Electrical Gear at Load Side A1	1~65535	100
✓ 10-05	Electrical Gear at Motor Side B1	1~65535	100
✓ 10-06	Electrical Gear at Load Side A2	1~65535	100
✓ 10-07	Electrical Gear at Motor Side B2	1~65535	100
✓ 10-08	Treatment for Encoder Feedback Fault	0: Warn and keep operation 1: Warn and ramp to stop 2: Warn and coast to stop	2
✓ 10-09	Detection Time of Encoder Feedback Fault	0.0~10.0 sec. 0: No function	1.0
✓ 10-10	Encoder Stall Level	0~120% 0: No function	115
✓ 10-11	Detection Time of Encoder Stall	0.0 ~ 2.0 sec.	0.1
✓ 10-12	Treatment for Encoder Stall	0: Warn and keep operation 1: Warn and ramp to stop 2: Warn and coast to stop	2
✓ 10-13	Encoder Slip Range	0~50% (0: disable)	50
✓ 10-14	Detection Time of Encoder Slip	0.0~10.0 sec.	0.5
✓ 10-15	Treatment for Encoder Stall and Slip Error	0: Warn and keep operation 1: Warn and ramp to stop 2: Warn and coast to stop	2
10-16 ~ 10-23	Reserved	-	-

	Parameter	Explanation	Settings	Factory Setting
✓	10-24	FOC&TQC Function Control	0~65535	0
✓	10-25	FOC Bandwidth of Speed Observer	20.0~100.0Hz	40.0
✓	10-26	FOC Minimum Stator Frequency	0.0~10.0%fN	2.0
✓	10-27	FOC Low-pass Filter Time Constant	1~1000ms	50
✓	10-28	FOC Excitation Current Rise Time	33~100%Tr	100
✓	10-29	Top Limit of Frequency Deviation	0.00~100.00Hz	20.00
	10-30	Reserved	-	-
✓	10-31	Obeserver Gain	0~65535	600
✓	10-32	PM Sensorless Obeserver Bandwith for High Speed Zone	0.00~600.00Hz	4.00
✓	10-33	PM Sensorless Obeserver Bandwith for Low Speed Zone	0.00~600.00Hz	0.50
✓	10-34	PM Sensorless Observer Low-pass Filter Gain	0.00~655.35	1.00
✓	10-35	Reserved	-	-
✓	10-36	Reserved	-	-
✓	10-37	PM Sensorless Control Word	0000h~FFFFh	0000
✓	10-38	Required Time for PM Sensorless d-axis Current Command Return to 0	0.0~6553.5 sec	1.0
✓	10-39	PM Sensorless Frequency Level to switch from V/F Mode to Detection Mode	0.00~600.00Hz	20.00
✓	10-40	PM Sensorless Frequency Level to switch from Detection Mode to V/F Mode	0.00~600.00Hz	20.00
✓	10-41	I/F mode, low pass-filter time	0.0~6.0sec	0.2
✓	10-42	Initial Angle Detection Time	0~10ms	0
	10-43 ~ 10-46	Reserved	-	-
✓	10-47	The Filter Time of the Low Resolution ppr Encoder at Low Speed	1~2000	2

Parameter	Explanation	Settings	Factory Setting
10-48	The Switching Frequency of the Calculation Method for the Low Resolution ppr Encoder at Low Speed	25.00~600.00Hz	25.00

11 Advanced Parameters



NOTE IM: Induction Motor; PM: Permanent Magnet Motor

Parameter	Explanation	Settings	Factory Setting
11-00	System Control	bit 0: Auto tuning for ASR and APR bit 1: Inertia estimate (only for FOC PG mode) bit 2: Zero servo bit 3: Dead Time compensation closed bit 7: Selection to save or not save the frequency	0
↗ 11-01	Per Unit of System Inertia	1~65535 (256=1PU)	400
↗ 11-02	ASR1/ASR2 Switch Frequency	5.00~600.00Hz (0: Disable)	7.00
↗ 11-03	ASR1 Low-speed Bandwidth	1~40Hz (IM)/ 1~100Hz (PM)	10
↗ 11-04	ASR2 High-speed Bandwidth	1~40Hz (IM)/ 1~100Hz (PM)	10
↗ 11-05	Zero-speed Bandwidth	1~40Hz (IM)/ 1~100Hz (PM)	10
↗ 11-06	ASR Control (P) 1	0~40Hz (IM)/ 1~100Hz (PM)	10
↗ 11-07	ASR Control (I) 1	0.000~10.000 sec.	0.100
↗ 11-08	ASR Control (P) 2	0~40Hz (IM)/ 0~100Hz (PM)	10
↗ 11-09	ASR Control (I) 2	0.000~10.000 sec.	0.100
↗ 11-10	P Gain of Zero Speed	0~40Hz (IM)/ 0~100Hz (PM)	10
↗ 11-11	I Gain of Zero Speed	0.000~10.000 sec.	0.100
↗ 11-12	Gain for ASR Speed Feed Forward	0~100%	0
↗ 11-13	PDF Gain	0~200%	30
↗ 11-14	Low-pass Filter Time of ASR Output	0.000~0.350 sec.	0.008
↗ 11-15	Notch Filter Depth	0~20db	0
↗ 11-16	Notch Filter Frequency	0.00~200.00Hz	0.00
↗ 11-17	Forward Motor Torque Limit	0~500%	500
↗ 11-18	Forward Regenerative Torque Limit	0~500%	500
↗ 11-19	Reverse Motor Torque Limit	0~500%	500
↗ 11-20	Reverse Regenerative Torque Limit	0~500%	500
↗ 11-21	Gain Value of Flux Weakening Curve for Motor 1	0~200%	90
↗ 11-22	Gain Value of Flux Weakening Curve for Motor 2	0~200%	90

	Parameter	Explanation	Settings	Factory Setting
↗	11-23	Speed Response of Flux Weakening Area	0~150%	65
	11-24 ~ 11-26	Reserved	-	-
↗	11-27	Max. Torque Command	0~500%	100
↗	11-28	Source of Torque Offset	0: No function 1: Analog signal input (Pr.03-00) 2: RS485 communication (Pr.11-29) 3: Control by external terminal (Pr.11-30~11-32)	0
↗	11-29	Torque Offset Setting	0~100%	0.0
↗	11-30	High Torque Offset	0~100%	30.0
↗	11-31	Middle Torque Offset	0~100%	20.0
↗	11-32	Low Torque Offset	0~100%	10.0
↗	11-33	Source of Torque Command	0: Digital keypad 1: RS-485 communication (Pr.11-34) 2: Analog input (Pr.03-00) 3: CANopen	0
↗	11-34	Torque Command	-100.0~+100.0% (Pr.11-27=100%)	0.0
↗	11-35	Filter Time of Torque Command	0.000~1.000 sec.	0.000
	11-36	Speed Limit Selection	0: Set by Pr.11-37 (Forward speed limit) and Pr.11-38 (Reverse speed limit) 1: Set by Pr.11-37,11-38 and Pr.00-20 (Source of Master Frequency Command) 2: Set by Pr.00-20 (Source of Master Frequency Command).	0
↗	11-37	Forward Speed Limit (torque mode)	0~120%	10
↗	11-38	Reverse Speed Limit (torque mode)	0~120%	10
	11-39	Zero Torque Command Mode	0: Torque mode 1: Speed mode	0
	11-40 ~ 11~41	Reserved	-	-
↗	11-42	System Control 2	0~65535	0

Chapter 10 Description of Parameter Settings

10-1 Description of Parameter Settings

NOTE: When the value of Pr.00-14 is modified, all the values of parameters will be back to the factory setting. So set up Pr.00-14 BEFORE setting up other parameters.

00 Drive Parameters

✎ This parameter can be set during operation.

00-00

Identity Code of the AC Motor Drive

Factory Setting: ##

Settings Read Only

00-01

Display AC Motor Drive Rated Current

Factory Setting: ##

Settings Read Only

📖 Pr. 00-00 displays the identity code of the AC motor drive. Using the following table to check if Pr.00-01 setting is the rated current of the AC motor drive. Pr.00-01 corresponds to the identity code Pr.00-01.

📖 The factory setting is the rated current for normal duty. Please set Pr.00-16 to 1 to display the rated current for the heavy duty.

230V Series					
Frame	A0				
kW	0.4	0.75	1.5	2.2	3.7
HP	0.5	1	2	3	5
Pr.00-00	2	4	6	8	10
Rated Current for Heavy Duty (A)	2.8	4.8	7.1	10	16
Rated Current for Normal Duty (A)	3	5	8	11	17

460V Series							
Frame	A0					A	
kW	0.75	1.5	2.2	3.7	4.0	5.5	7.5
HP	1	2	3	5	5.5	7.5	10
Pr.00-00	5	7	9	11	93	13	15
Rated Current for Heavy Duty (A)	2.9	3.8	5.7	8.1	9.5	11	17
Rated Current for Normal Duty (A)	3.0	4.0	6.0	9.0	10.5	12	18

00-02

Parameter Reset

Factory Setting: 0

Settings 0: No Function

1: Write protection for parameters

5: Reset KWH display to 0

6: Reset PLC (includes CANopen Master Index)

7: Reset CANopen Index (Slave)

9: All parameters are reset to factory settings (base frequency is 50Hz)

10: All parameters are reset to factory settings (base frequency is 60Hz)

- 📖 When it is set to 1, all parameters are read only except Pr.00-02~00-08 and it can be used with password setting for password protection. It needs to set Pr.00-02 to 0 before changing other parameter settings.
- 📖 When it is set to 9 or 10: all parameters are reset to factory settings. If password is set in Pr.00-08, input the password set in Pr.00-07 to reset to factory settings.
- 📖 When it is set to 5, KWH display value can be reset to 0 even when the drive is operating. Pr. 05-26, 05-27, 05-28, 05-29, 05-30 reset to 0.
- 📖 When it is set to 6: clear internal PLC program
- 📖 When it is set to 7: reset the related settings of CANopen slave.

↗ **00-03** Start-up Display Selection

Factory setting: 0

- Settings
- 0: Display the frequency command (F)
 - 1: Display the actual output frequency (H)
 - 2: Display User define (U)
 - 3: Output current (A)

- 📖 This parameter determines the start-up display page after power is applied to the drive. User defined choice display according to the setting in Pr.00-04.

↗ **00-04** Content of Multi-function Display

Factory setting: 3

- Settings
- 0: Display output current (A)
 - 1: Display counter value (c)
 - 2: Display actual output frequency (H.)
 - 3: Display DC-BUS voltage (v)
 - 4: Display output voltage (E)
 - 5: Display output power angle (n)
 - 6: Display output power in kW (P)
 - 7: Display actual motor speed rpm (r = 00: positive speed; -00 negative speed)
 - 8: Display estimate output torque % (t = 00: positive torque; -00 negative torque) (t) (refer to Note 4)
 - 9: Reserved
 - 10: Display PID feedback in % (b)
 - 11: Display AVI in % (1.), 0~10V/4-20mA/0-20mA corresponds to 0~100% (Refer to Note 1)
 - 12: Display ACI in % (2.), 4~20mA/0~10V/0-20mA corresponds to 0~100% (Refer to Note 1)
 - 13: Display AUI in % (3.), -10V~10V corresponds to -100~100%(Refer to Note 2)
 - 14: Display the temperature of IGBT in oC (i.)
 - 15: Display the temperature of heat sink in oC (c.)

- 16: The status of digital input (ON/OFF) refer to Pr.02-12 (i) (Refer to Note 2)
- 17: Display digital output status ON/OFF (Pr.02-18) (o) (Refer to NOTE 3)
- 18: Display the multi-step speed that is executing (S)
- 19: The corresponding CPU pin status of digital input (d) (refer to NOTE 2)
- 20: The corresponding CPU pin status of digital output (0.) (refer to NOTE 3)
- 21~24: Reserved
- 25: Overload counting (0.00~100.00%) (h.) (Refer to Note 5)
- 26: GFF Ground Fault (Unit :%)(G.)
- 27: DC Bus voltage ripple (Unit: Vdc)(r.)
- 28: Display PLC register D1043 data (C) display in hexadecimal
- 29: Reserved
- 30 : Display output of user defined (U)
- 31 : H page x 00-05 Display user Gain(K)
- 32~34: Reserved
- 35: Control Mode display: 0= Speed control mode (SPD), 1= torque control mode (TQR) (t.)
- 36: Present operating carrier frequency of drive (Hz) (J.)

 **NOTE**

1. It can display negative values when setting analog input bias (Pr.03-03~03-10).
Example: assume that AVI input voltage is 0V, Pr.03-03 is 10.0% and Pr.03-07 is 4 (Serve bias as the center).
2. Example: If REV, MI1 and MI6 are ON, the following table shows the status of the terminals.
0: OFF, 1: ON

Terminal	MI8	MI7	MI6	MI5	MI4	MI3	MI2	MI1	REV	FWD
Status	0	0	1	0	0	0	0	1	1	0

If REV, MI1 and MI6 are ON, the value is 0000 0000 1000 0110 in binary and 0086h in HEX. When Pr.00-04 is set to “16” or “19”, it will display “0086h” with LED U is ON on the keypad KPC-CE01. The setting 16 is the status of digital input by Pr.02-12 setting and the setting 19 is the corresponding CPU pin status of digital input, the FWD/REV action and the three-wire MI are not controlled by Pr.02-12. User can set to 16 to monitor digital input status and then set to 19 to check if the wire is normal.

3. Assume that RY1: Pr.02-13 is set to 9 (Drive ready). After applying the power to the AC motor drive, if there is no other abnormal status, the contact will be ON. The display status will be shown as follows.

N.O. switch status:

Terminal	Reserved			Reserved			Reserved			DFM2	DFM1	Reserved	RY2	RY1
Status	0	0	0	0	0	0	0	0	0	0	0	0	0	1

At the meanwhile, if Pr.00-04 is set to 17 or 20, it will display in hexadecimal “0001h” with LED U is ON on the keypad. The setting 17 is the status of digital output by Pr.02-18 setting and the setting 20 is the corresponding CPU pin status of digital output. User can set 17 to monitor the digital output status and then set to 20 to check if the wire is normal.

4. Setting 8: 100% means the motor rated torque. Motor rated torque = (motor rated power x60/2π)/motor rated speed
5. If Pr.00-04 = 25, when display value reaches 100.00%, the drive will show “oL” as an overload warning.

00-05 Coefficient Gain in Actual Output Frequency

Factory Setting: 0

Settings 0~160.00

This parameter is to set coefficient gain in actual output frequency. Set Pr.00-04= 31 to display the calculation result on the screen (calculation = output frequency * Pr.00-05).

00-06 Software Version

Factory Setting: #.#

Settings Read only

00-07 Parameter Protection Password Input

Factory Setting: 0

Settings 1~9998, 10000~65535

Display 0~3 (the times of password attempts)

- This parameter allows user to enter their password (which is set in Pr.00-08) to unlock the parameter protection and to make changes to the parameter.
- Pr.00-07 and Pr.00-08 are used to prevent the personal misoperation.
- When the user have forgotten the password, clear the setting by input 9999 and press ENTER key, then input 9999 again and press Enter within 10 seconds. After decoding, all the settings will return to factory setting.

00-08 Parameter Protection Password Setting

Factory Setting: 0

Settings 1~9998, 10000~65535

0: No password protection / password is entered correctly (Pr00-07)

1: Password has been set

- To set a password to protect your parameter settings. If the display shows 0, no password is set nor password has been correctly entered in Pr.00-07. All parameters can then be changed, including Pr.00-08. The first time you can set a password directly. After successful setting of password the display will show 1. Be sure to write down the password for later use. To cancel the parameter lock, set the parameter to 0 after inputting correct password into Pr. 00-07.
- How to retrieve parameter protection after decoding by Pr.00-07:
 - Method 1: Re-enter the password to Pr.00-08 (input the password once).
 - Method 2: After reboots, password function will be recovered.
 - Method 3: Input any value into Pr.00-07 (Do not enter the password).

Password Decode Flow Chart

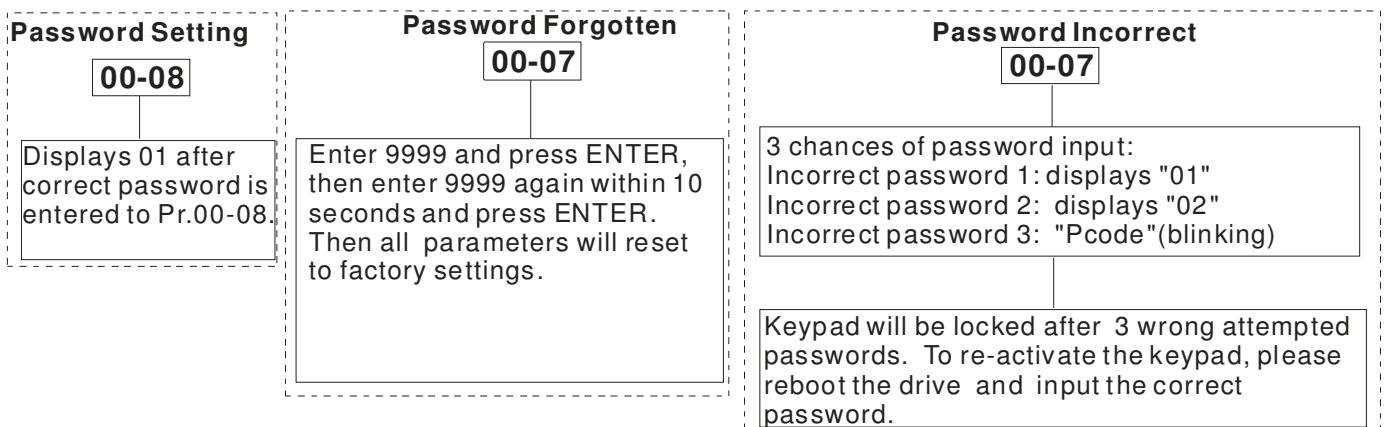

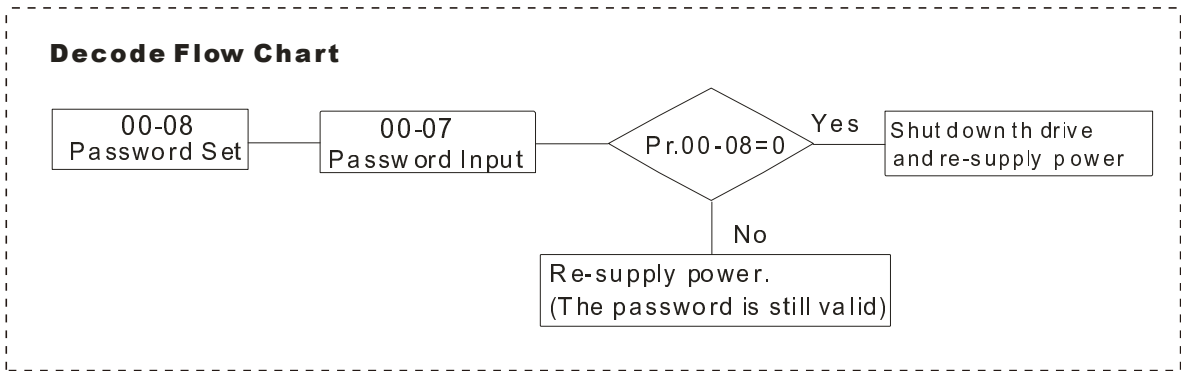

00-09 Reserved

00-10 Control Mode

Factory Setting: 0

- Settings
- 0: Speed mode (Pr.00-11)
 - 1: Reserved
 - 2: Torque mode (Pr.00-13)
 - 3: Reserved

This parameter determines the control mode of C200 series AC motor drive.

00-11 Control of Speed Mode

Factory Setting: 0

- Settings
- 0: V/F (IM V/f control)
 - 1: VFPG (IM V/F control+ Encoder)
 - 2: SVC(IM sensorless vector control)
 - 3: FOCPG (IM FOC vector control+ encoder)
 - 4: Reserved
 - 5: FOC Sensorless (IM field oriented sensorless vector control)
 - 6 : PM Sensorless (PM field oriented sensorless vector control)

This parameter determines the control method of the AC motor drive:

- 0: (IM V/f control): user can design proportion of V/f as required and can control multiple motors simultaneously.
- 1: (IM V/f control + Encoder): user can use optional PG card with encoder for the closed-loop speed control.
- 2: (IM Sensorless vector control): get the optimal control by the auto-tuning of motor parameters.
- 3: (IM FOC vector control+ encoder): besides torque increases, the speed control will be more accurate (1:1000).
- 5: FOC Sensorless (IM field oriented sensorless vector control)
- 6: PM Sensorless (PM field oriented sensorless vector control)

When setting Pr.00-11 to 0, the V/F control diagram is shown as follows.

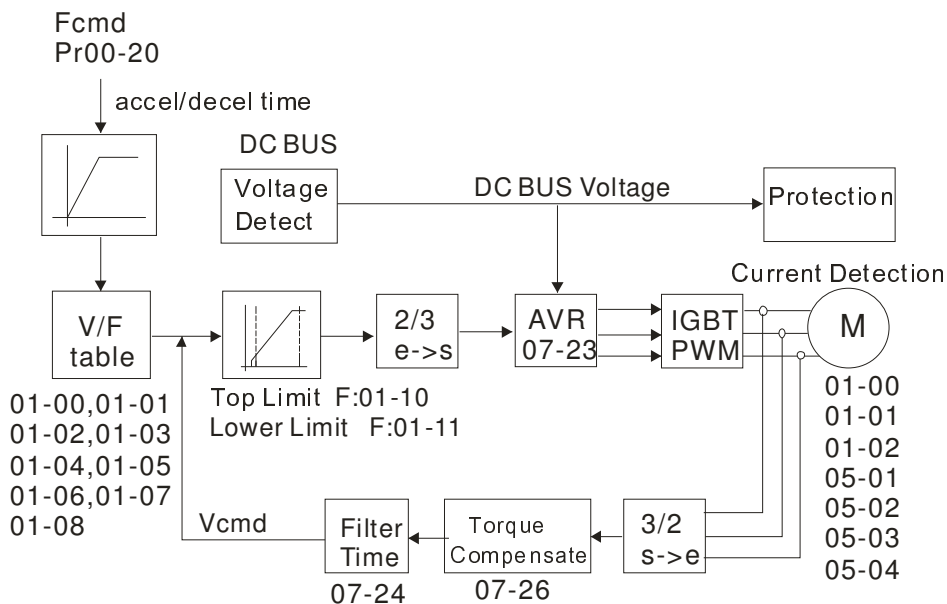

When setting Pr.00-11 to 1, the V/F control + encoder diagram is shown as follows.

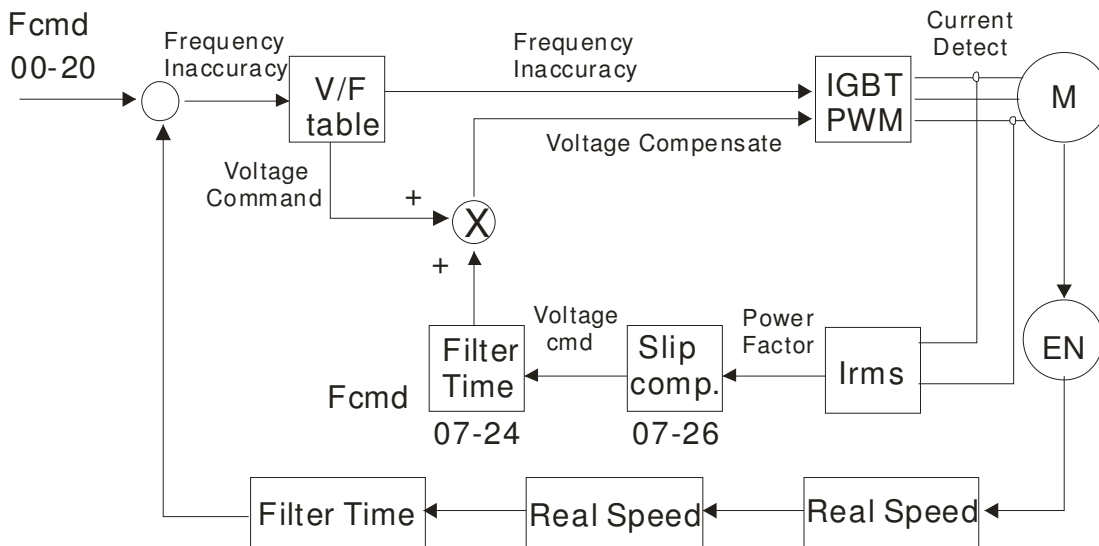

When setting Pr.00-11 to 2, the sensorless vector control diagram is shown as follows.

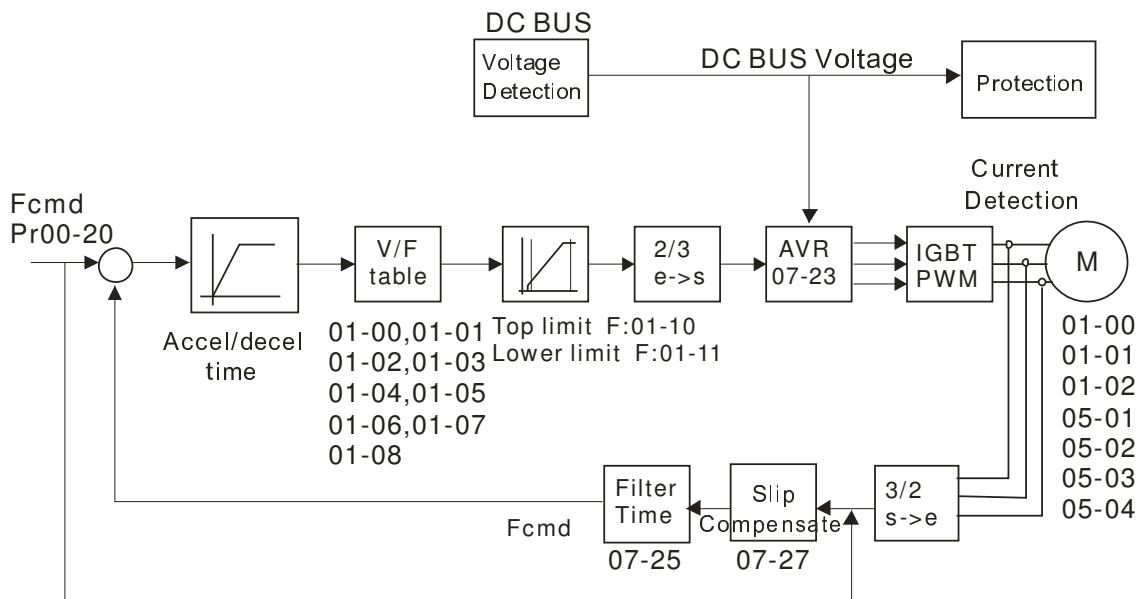

When setting Pr.00-11 to 3, the FOCPG control diagram is shown as follows.

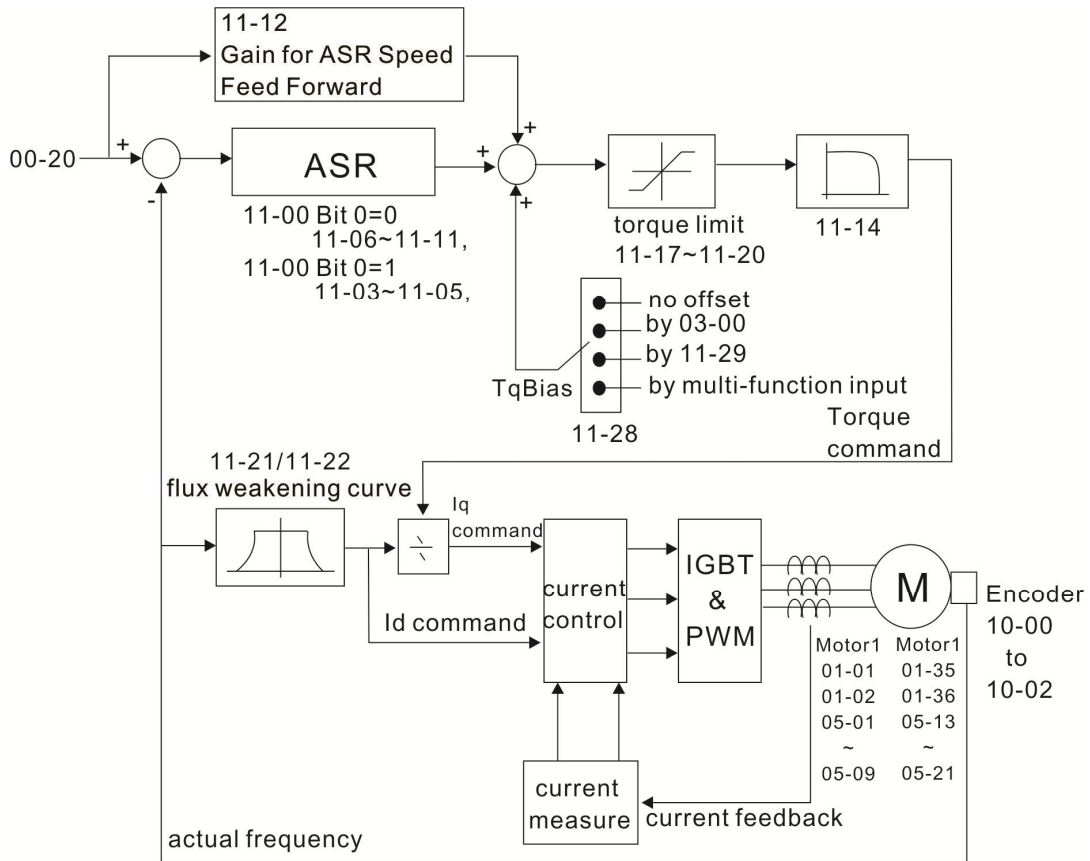

When setting Pr.00-11 to 5, the FOC sensorless (IM) control diagram is shown as follows.

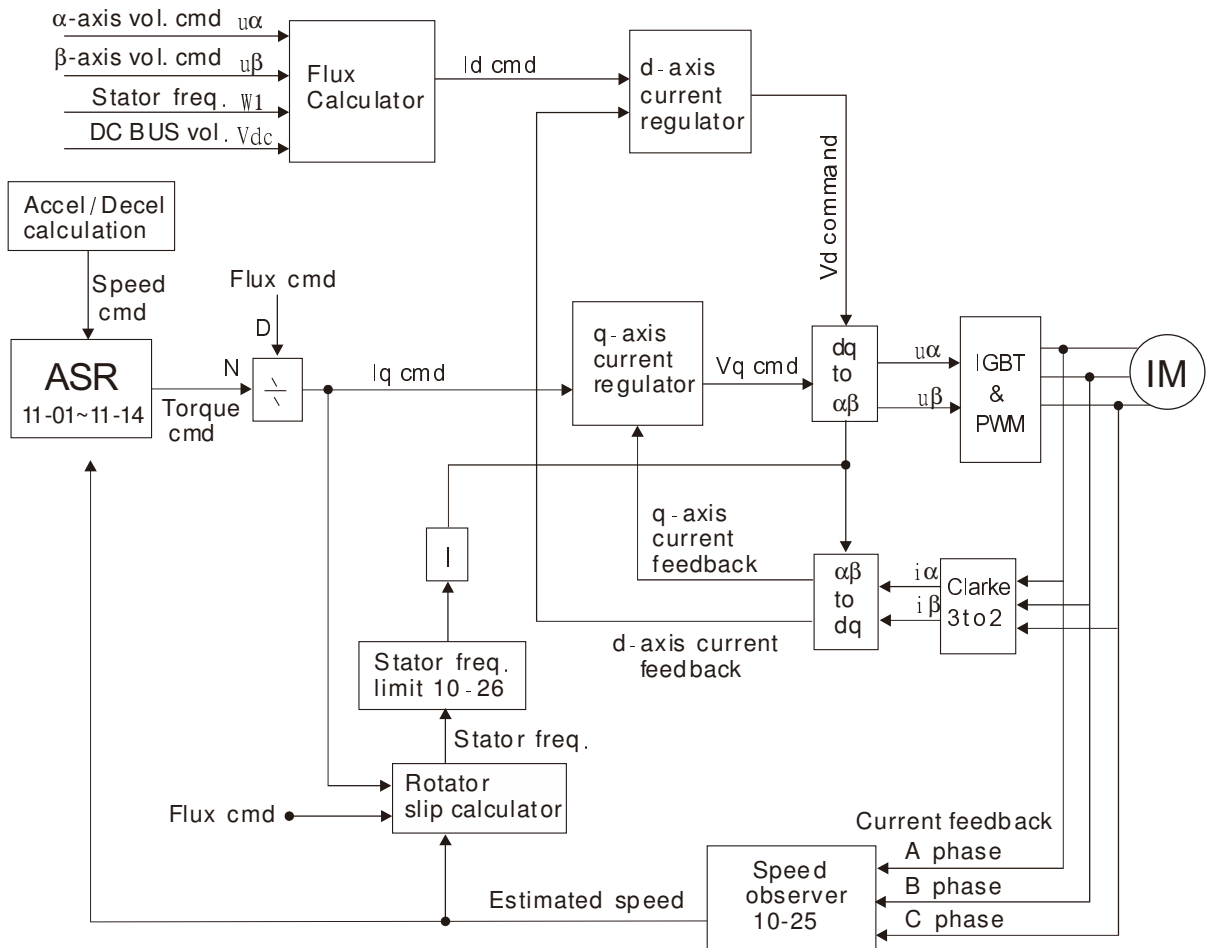

When setting Pr.00-11 to 6, PM FOC sensorless control diagram is shown as follows:

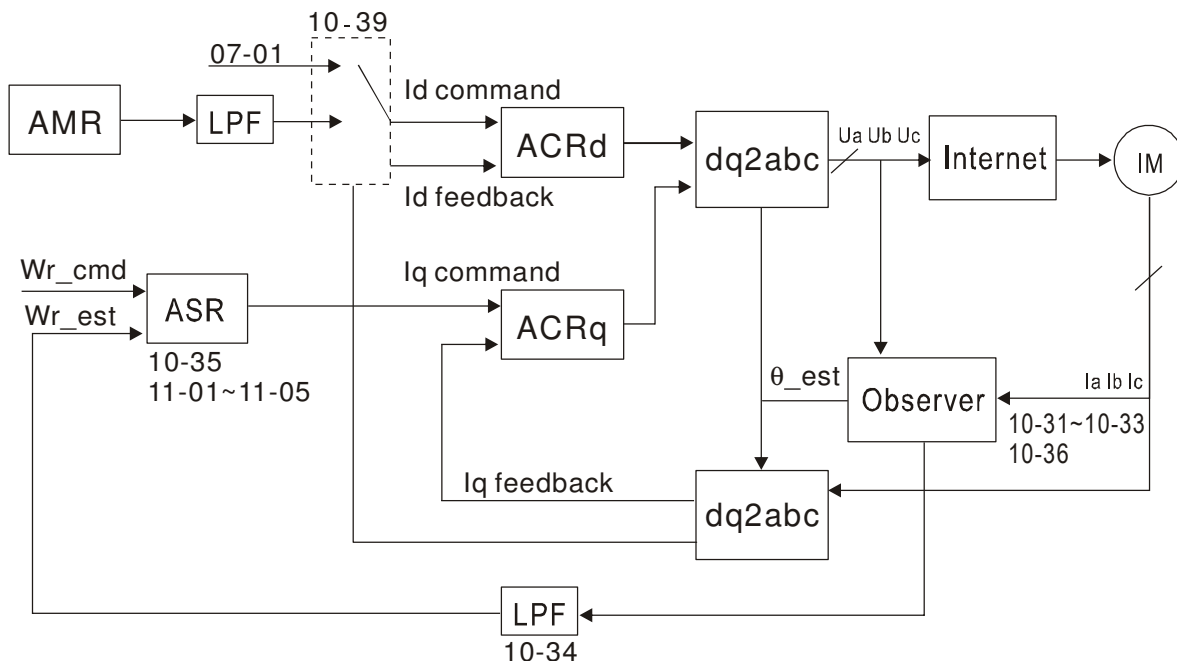

00-12	Reserved
00-13	Control of Torque Mode

Factory Setting: 0

- Settings
- 0: TQCPG (IM Torque control + Encoder)
 - 1: Reserved
 - 2: TQC Sensorless (IM sensorless torque control)

TQCPG control diagram is shown in the following:

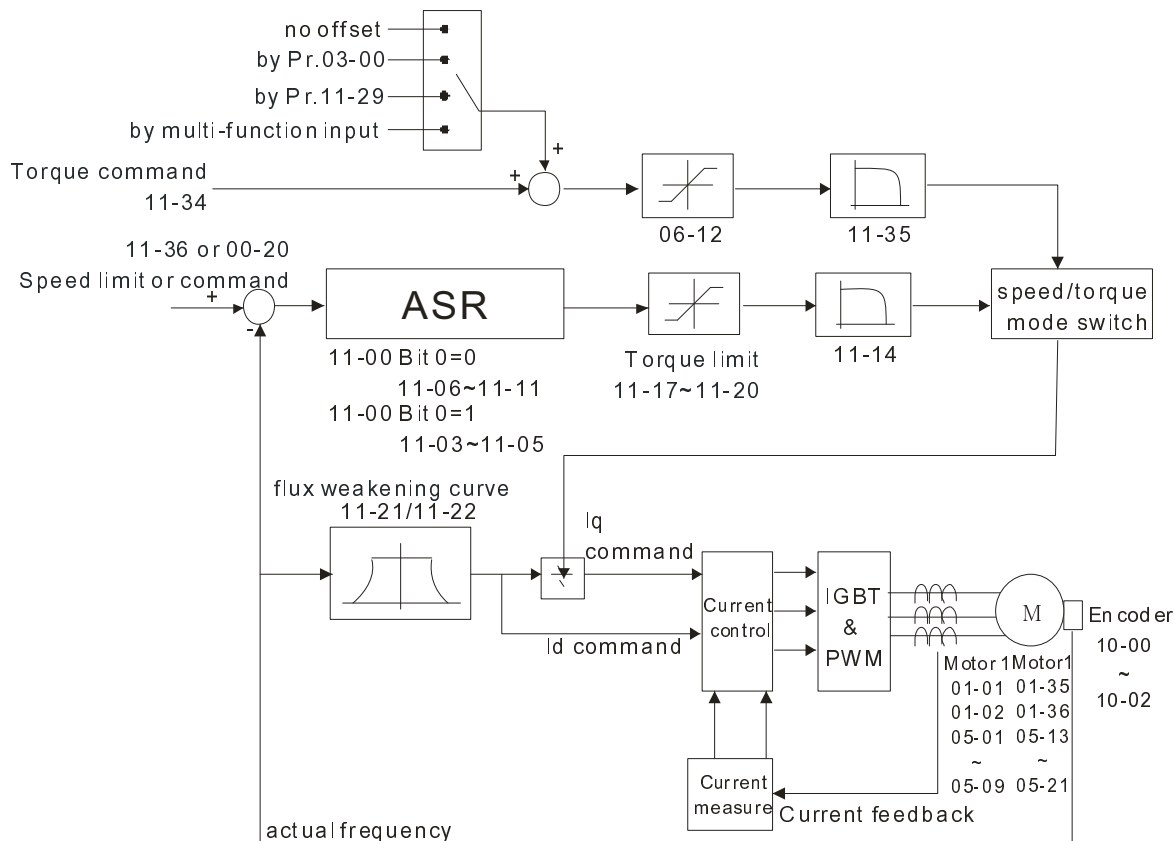

TQC Sensorless control diagram is shown in the following:

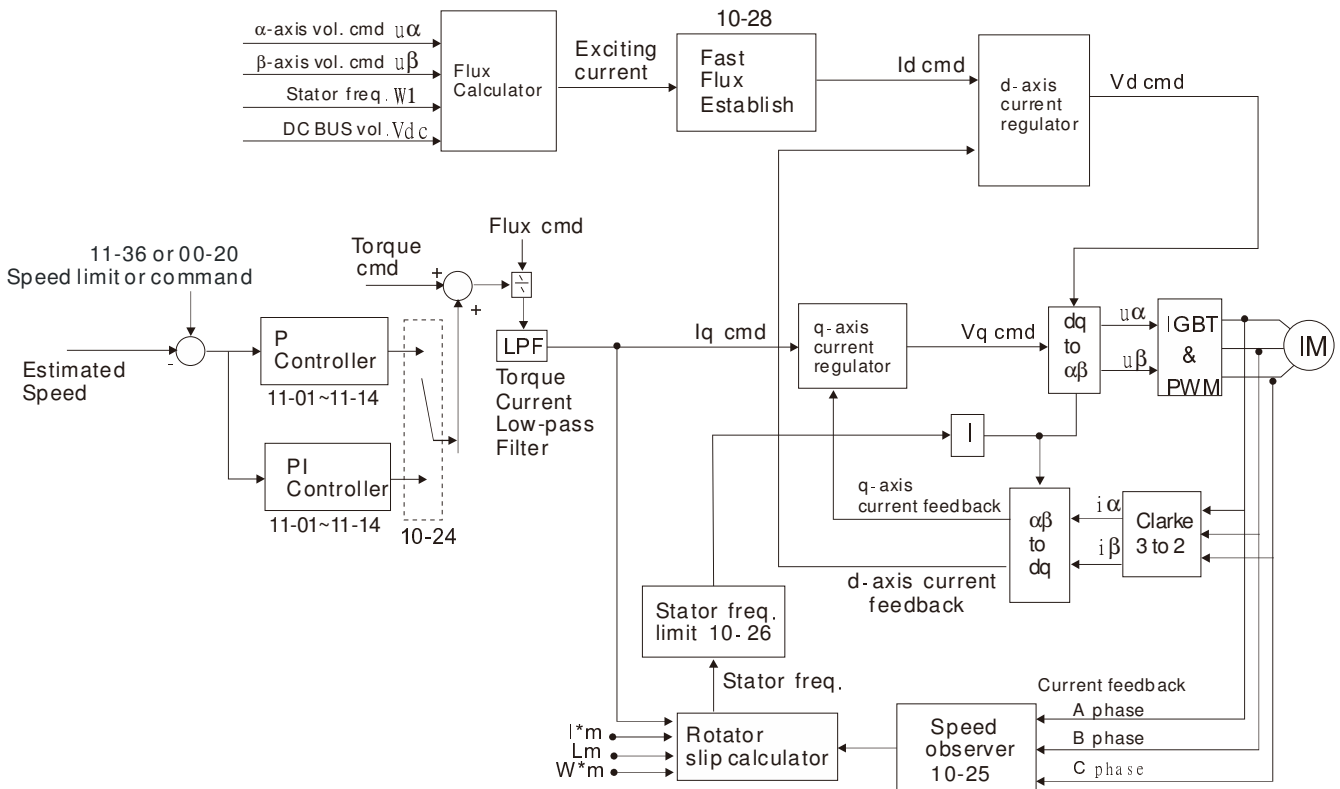

00-14 High Speed Mode Setting (When the value of Pr.00-14 is modified; all the values of parameters will be back to the factory setting. So set up Pr.00-14 BEFORE setting up other parameters.)

Factory setting: 0

Settings 0: Standard mode

1 ↵ 2 ↵: Enable high speed frequency output(Max. Output Frequency 2,000Hz)

1 ↵ 0 ↵: Disable high speed frequency output(Max. Output Frequency: ND & HD:600Hz)

Before setting this parameter, please verify if a high speed motor will be in use. When switching between standard mode and high speed mode, all the value of parameters will be back to the factory setting. . In other words, set up Pr.00-14 before setting up other parameters of C200.

To enable high speed frequency output function, set Pr00-14 to 1, and then set it to 2. These two steps have to be completed to enable this function.

To disable high speed frequency output function, set Pr00-14 to 1, and then set it to 0. These two steps have to be completed to disable this function.

00-15 Reserved

00-16 Load Selection

Factory Setting: 0

Settings 0: Normal load

1: Heavy load

Normal duty: over load, rated output current 160% in 3 second. Please refer to Pr.00-17 for the setting of carrier wave. Refer to chapter specifications or Pr.00-01 for the rated current.

Heavy duty: over load, rated output current 180% in 3 second. Please refer to Pr.00-17 for the setting of carrier wave. Refer to chapter specifications or Pr.00-01 for the rated current.

00-17 Carrier FrequencyFactory setting: **6**

Settings 2~15kHz

 This parameter determinates the PWM carrier frequency of the AC motor drive.

	230V Series		460V Series
Models	1-Phase 0.4-2.2kW	3-Phase 0.4-3.7 kW	3-Phase 0.75-7.5kW
Setting Range	02~15kHz		02~15kHz
Normal Duty Factory Setting	6kHz		6kHz
Heavy Duty Factory Setting	6kHz		6kHz

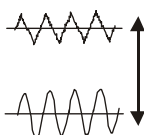
Carrier Frequency	Acoustic Noise	Electromagnetic Noise or Leakage Current	Heat Dissipation	Current Wave
1kHz	Significant ↑ ↓ Minimal	Minimal ↑ ↓ Significant	Minimal ↑ ↓ Significant	
6kHz				
15kHz				

 From the table, we see that the PWM carrier frequency has a significant influence on the electromagnetic noise, AC motor drive heat dissipation, and motor acoustic noise. Therefore, if the surrounding noise is greater than the motor noise, lower the carrier frequency is good to reduce the temperature rise. Although it is quiet operation in the higher carrier frequency, the entire wiring and interference resistance should be considerate.

 When the carrier frequency is higher than the factory setting, it needs to protect by decreasing the carrier frequency. See Pr.06-55 for the related setting and details.

00-18 Single or Three-phase setting

Factory Setting: Read Only

Settings 0: 3-phase

1: 1-phase

 When Pr.00-00=2, 00-18=0 : 230V, 0.4kW, 3-Phase

Pr.00-00=2, 00-18=1 : 230V, 0.4kW, 1-Phase

Pr.00-00=4, 00-18=0 : 230V, 0.75kW, 3-Phase

Pr.00-00=4, 00-18=1 : 230V, 0.75kW, 1-Phase

Pr.00-00=5, 00-18=0 : 460V, 0.75kW

Pr.00-00=6, 00-18=0 : 230V, 1.5kW, 3-Phase

Pr.00-00=6, 00-18=1 : 230V, 1.5kW, 1-Phase

Pr.00-00=7, 00-18=0 : 460V, 1.5kW

Pr.00-00=8, 00-18=0 : 230V, 2.2kW, 3-Phase

Pr.00-00=8, 00-18=1 : 230V, 2.2kW, 1-Phase

Pr.00-00=9, 00-18=0 : 460V, 2.2kW

Pr.00-00=10, 00-18=0 : 230V, 3.7kW, 3-Phase

Pr.00-00=11, 00-18=0 : 460V, 3.7kW

Pr.00-00=13, 00-18=0 : 230V, 5.5kW

Pr.00-00=15, 00-18=0 : 460V, 7.5kW

Pr.00-00=93, 00-18=0 : 460V, 4.0kW

00-19 PLC Command Mask

Factory Setting: Read Only

- Settings
- bit 0: Control command compulsively controlled by PLC
 - bit 1: Frequency command compulsively controlled by PLC
 - Bit 3: Torque command compulsively controlled by PLC

 This parameter determines if control command, frequency command or torque command is occupied by PLC

00-20 Source of the Master Frequency Command (AUTO)

Factory Setting: 0

- Settings
- 0: Digital keypad (KPE-LE02)
 - 1: RS-485 serial communication or KPC-CC01 (optional)
 - 2: External analog input (Pr.03-00)
 - 3: External UP/DOWN terminal (multiple input terminal)
 - 4~5: Reserved
 - 6: CANopen communication card
 - 7: Digital keypad potentiometer

 It is used to set the source of the master frequency in AUTO mode.

 Pr.00-20 and 00-21 are for the settings of frequency source and operation source in AUTO mode. Pr.00-30 and 00-31 are for the settings of frequency source and operation source in HAND mode. The AUTO/HAND mode can be switched by the keypad KPC-CC01 or multi-function input terminal (MI).

 The factory setting of frequency source or operation source is for AUTO mode. It will return to AUTO mode whenever power on again after power off. If there is multi-function input terminal used to switch AUTO/HAND mode. The highest priority is the mutli-function input terminal. When the external terminal is OFF, the drive won't receive any operation signal and can't execute JOG.

00-21 Source of the Operation Command (AUTO)

Factory Setting: 0

- Settings
- 0: Digital keypad (KPE-LE02)
 - 1: External terminals. Keypad STOP disabled.
 - 2: RS-485 serial communication. Keypad STOP disabled.
 - 3: CANopen communication

 It is used to set the source of the operation frequency in AUTO mode.

 When the operation command is controlled by the keypad KPC-CC01, keys RUN, STOP and JOG (F1) are valid.

00-22 Stop Method

Factory Setting: 0

Settings 0: Ramp to stop
1: Coast to stop

The parameter determines how the motor is stopped when the AC motor drive receives a valid stop command.

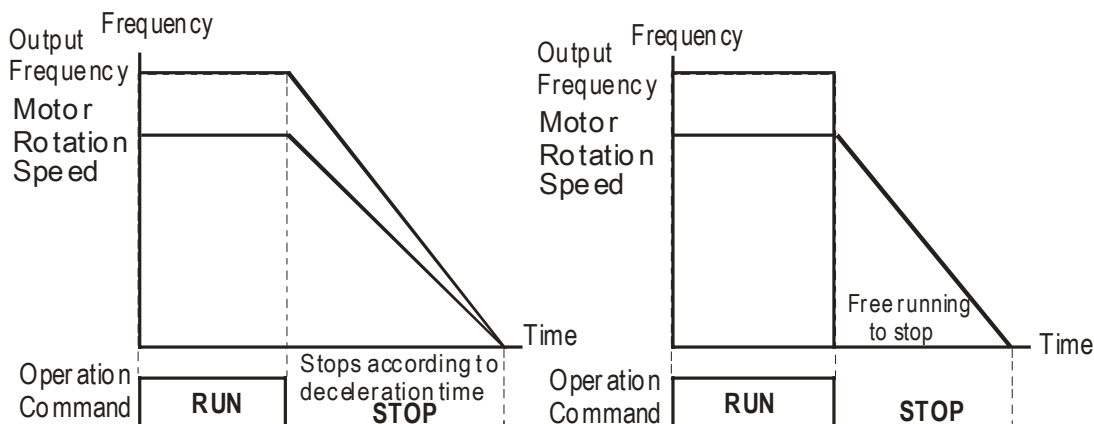

Ramp to Stop and Coast to Stop

Ramp to stop: the AC motor drive decelerates from the setting of deceleration time to 0 or minimum output frequency (Pr. 01-09) and then stop (by Pr.01-07).

Coast to stop: the AC motor drive stops the output instantly upon a STOP command and the motor free runs until it comes to a complete standstill.

(1) It is recommended to use “ramp to stop” for safety of personnel or to prevent material from being wasted in applications where the motor has to stop after the drive is stopped. The deceleration time has to be set accordingly.

(2) If the motor free running is allowed or the load inertia is large, it is recommended to select “coast to stop”. For example, blowers, punching machines and pumps

The stop method of the torque control is also set by Pr.00-22.

00-23 Control of Motor Direction

Factory Setting: 0

Settings 0: Enable forward/ reverse
1: Disable reverse
2: Disable forward

This parameter enables the AC motor drives to run in the forward/reverse Direction. It may be used to prevent a motor from running in a direction that would consequently injure the user or damage the equipment.

00-24 Memory of Frequency Command

Factory Setting: Read Only

Settings Read only

If keypad is the source of frequency command, when Lv or Fault occurs the present frequency command will be saved in this parameter.

00-25 User Defined Characteristics

Factory Setting: 0

Settings bit 0~3: user define on decimal place
 0000b: no decimal place
 0001b: one decimal place
 0010b: two decimal place
 0011b: three decimal place
 bit 4~15: user define on unit
 000xh: Hz
 001xh: rpm
 002xh: %
 003xh: kg
 004xh: m/s
 005xh: kW
 006xh: HP
 007xh: ppm
 008xh: 1/m
 009xh: kg/s
 00Axh: kg/m
 00Bxh: kg/h
 00Cxh: lb/s
 00Dxh: lb/m
 00Exh: lb/h
 00Fxm: ft/s
 010xh: ft/m
 011xh: m
 012xh: ft
 013xh: degC
 014xh: degF
 015xh: mbar
 016xh: bar
 017xh: Pa
 018xh: kPa
 019xh: mWG
 01Axh: inWG
 01Bxh: ftWG
 01Cxh: psi
 01Dxh: atm
 01Exh: L/s
 01Fxm: L/m
 020xh: L/h
 021xh: m³/s
 022xh: m³/h
 023xh: GPM
 024xh: CFM
 xxxxh: Hz

 bit 0~3: F & H page unit and Pr.00-26 decimal display is supported up to 3 decimal places.

 bit 4~15: F & H page unit and Pr.00-26 unit display is supported up to 4 types of unit display.

00-26 Max. User Defined Value

Factory Setting: 0

Settings 0: Disable
 0~65535 (when Pr.00-25 set to no decimal place)
 0.0~6553.5 (when Pr.00-25 set to 1 decimal place)
 0.0~655.35 (when Pr.00-25 set to 2 decimal place)
 0.0~65.535 (when Pr.00-25 set to 3 decimal place)

 User define is enabled when Pr.00-26 is not 0. The setting of Pr.00-26 corresponds to Pr.01.00 (Max. output frequency of the drive).

Example: User define: 100.0%, Pr.01-00 = 60.00Hz

Pr.00-25 setting is 0021h; Pr.00-26 setting is 100.0%

 **NOTE**

The drive will display as Pr.00-25 setting when Pr.00-25 is properly set and Pr.00-26 is not 0.

00-27 User Defined Value

Factory Setting: Read only

Settings Read only

 Pr.00-27 will show user defined value when Pr.00-26 is not set to 0.

 User defined function is valid when Pr.00-20 is set to digital keypad control or RS-285 communication input control.

00-28 Reserved

00-29 LOCAL/REMOTE Selection

Factory Setting: 0

Settings 0: Standard HOA function

1: Switching Local/Remote, the drive stops

2: Switching Local/Remote, the drive runs as the REMOTE setting for frequency and operation status

3: Switching Local/Remote, the drive runs as the LOCAL setting for frequency and operation status

4: Switching Local/Remote, the drive runs as LOCAL setting when switch to Local and runs as REMOTE setting when switch to Remote for frequency and operation status.

 The factory setting of Pr.00-29 is 0 (standard Hand-Off-Auto function). The AUTO frequency and source of operation can be set by Pr.00-20 and Pr.00-21, and the HAND frequency and source of operation can be set by Pr.00-30 and Pr.00-31. AUTO/HAND mode can be selected or switched by using digital keypad (KPC-CC01) or setting multi-function input terminal MI= 41, 42.

 When external terminal MI is set to 41 and 42 (AUTO/HAND mode), the settings Pr.00-29=1, 2, 3, 4 will be disabled. The external terminal has the highest priority among all command, Pr.00-29 will always function as Pr.00-29=0, standard HOA mode.

 When Pr.00-29 is not set to 0, Local/Remote function is enabled, the top right corner of digital keypad (KPC-CC01) will display "LOC" or "REM" (the display is available when KPC-CC01 is installed with firmware version higher than version 1.021). The LOCAL frequency and source of operation can be set by Pr.00-20 and Pr.00-21, and the REMOTE frequency and source of operation can be set by Pr.00-30 and Pr.00-31. Local/Remote function can be selected or switched by using digital keypad (KPC-CC01) or setting external terminal MI=56. The AUTO key of the digital keypad now controls for the REMOTE function and HAND key now controls for the LOCAL function.

 When MI is set to 56 for LOC/REM selection, if Pr.00-29 is set to 0, then the external terminal is disabled.

📖 When MI is set to 56 for LOC/REM selection, if Pr.00-29 is not set to 0, the external terminal has the highest priority of command and the ATUO/HAND keys will be disabled.

00-30 Source of the Master Frequency Command (HAND)

Factory Setting: 0

- Settings
- 0: Digital keypad (KPE-LE02)
 - 1: RS-485 serial communication or KPC-CC01 (optional)
 - 2: External analog input (Pr.03-00)
 - 3: External UP/DOWN terminal (multiple input terminal)
 - 4~5: Reserved
 - 5: Pulse input with direction command (Pr.10-16)
 - 6: CANopen communication
 - 7: Digital keypad potentiometer

📖 It is used to set the source of the master frequency in HAND mode.

00-31 Source of the Operation Command (HAND)

Factory Setting: 2

- Settings
- 0: Digital keypad (KPE-LE02)
 - 1: External terminals. Keypad STOP disabled.
 - 2: RS-485 serial communication or KPC-CC01 (optional). Keypad STOP disabled.
 - 3: CANopen communication

📖 It is used to set the source of the operation frequency in HAND mode.

📖 Pr.00-20 and 00-21 are for the settings of frequency source and operation source in AUTO mode. Pr.00-30 and 00-31 are for the settings of frequency source and operation source in HAND mode. The AUTO/HAND mode can be switched by the keypad KPC-CC01 or multi-function input terminal (MI).

📖 The factory setting of frequency source or operation source is for AUTO mode. It will return to AUTO mode whenever power on again after power off. If there is multi-function input terminal used to switch AUTO/HAND mode. The highest priority is the multi-function input terminal. When the external terminal is OFF, the drive won't receive any operation signal and can't execute JOG.

↙ **00-32** Digital Keypad STOP Function

Factory Setting: 0

- Settings
- 0: STOP key disable
 - 1: STOP key enable

00-33
~ Reserved

00-47

↗ **00-48** Display Filter Time (Current)

Factory Settings: 0.100

Settings: 0.001~65.535 sec.

 Set this parameter to minimize the current fluctuation displayed by digital keypad.

↗ **00-49** Display Filter Time (Keypad)

Factory Settings: 0.100

Settings: 0.001~65.535 sec.

 Set this parameter to minimize the display value fluctuation displayed by digital keypad.

00-50 Software Version (date)

Factory Settings: ####

Settings: Read only

 This parameter displays the drive's software version by date.

01 Basic Parameters

↗ This parameter can be set during operation.

01-00 Maximum Output Frequency

Factory Setting: 60.00/50.00

Settings 50.00~600.00Hz

📖 This parameter determines the AC motor drive's Maximum Output Frequency. All the AC motor drive frequency command sources (analog inputs 0 to +10V, 4 to 20mA, 0 to 20mA and $\pm 10V$) are scaled to correspond to the output frequency range.

01-01 Output Frequency of Motor 1 (base frequency and motor rated frequency)

01-35 Output Frequency of Motor 2 (base frequency and motor rated frequency)

Factory Setting: 60.00/50.00

Settings 0.00~600.00Hz

📖 This value should be set according to the rated frequency of the motor as indicated on the motor nameplate. If the motor is 60Hz, the setting should be 60Hz. If the motor is 50Hz, it should be set to 50Hz.

📖 Pr.01-35 is used for the application occasion that uses double base motor.

01-02 Output Voltage of Motor 1 (base frequency and motor rated frequency)

01-36 Output Voltage of Motor 2 (base frequency and motor rated frequency)

Factory Setting: 200.0/400.0

Settings 230V series: 0.0~255.0V

460V series: 0.0~510.0V

📖 This value should be set according to the rated voltage of the motor as indicated on the motor nameplate. If the motor is 220V, the setting should be 220.0. If the motor is 200V, it should be set to 200.0.

📖 There are many motor types in the market and the power system for each country is also difference. The economic and convenience method to solve this problem is to install the AC motor drive. There is no problem to use with the different voltage and frequency and also can amplify the original characteristic and life of the motor.

01-03 Mid-point Frequency 1 of Motor 1

Factory Setting: 3.00

Settings 0.00~600.00Hz

↗ **01-04** Mid-point Voltage 1 of Motor 1

Factory Setting: 11.0/22.0

Settings 230V series: 0.0~240.0V

460V series: 0.0~480.0V

01-37 Mid-point Frequency 1 of Motor 2

Factory Setting: 3.00

Settings 0.00~600.00Hz

↗	01-38 Mid-point Voltage 1 of Motor 2	Factory Setting: 11.0/22.0
	Settings 230V series: 0.0~240.0V 460V series: 0.0~480.0V	
	01-05 Mid-point Frequency 2 of Motor 1	Factory Setting: 0.50
	Settings 0.00~600.00Hz	
↗	01-06 Mid-point Voltage 2 of Motor 1	Factory Setting: 2.0/4.0
	Settings 230V series: 0.0~240.0V 460V series: 0.0~480.0V	
	01-39 Mid-point Frequency 2 of Motor 2	Factory Setting: 0.50
	Settings 0.00~600.00Hz	
↗	01-40 Mid-point Voltage 2 of Motor 2	Factory Setting: 2.0/4.0
	Settings 230V series: 0.0~240.0V 460V series: 0.0~480.0V	
	01-07 Min. Output Frequency of Motor 1	Factory Setting: 0.00
	Settings 0.00~600.00Hz	
↗	01-08 Min. Output Voltage of Motor 1	Factory Setting: 0.0/0.0
	Settings 230V series: 0.0~240.0V 460V series: 0.0~480.0V	
	01-41 Min. Output Frequency of Motor 2	Factory Setting: 0.00
	Settings 0.00~600.00Hz	
↗	01-42 Min. Output Voltage of Motor 2	Factory Setting: 0.0/0.0
	Settings 230V series: 0.0~240.0V 460V series: 0.0~480.0V	

- 📖 V/f curve setting is usually set by the motor's allowable loading characteristics. Pay special attention to the motor's heat dissipation, dynamic balance, and bearing lubricity, if the loading characteristics exceed the loading limit of the motor.
- 📖 There is no limit for the voltage setting, but a high voltage at low frequency may cause motor damage, overheat, and stall prevention or over-current protection. Therefore, please use the low voltage at the low frequency to prevent motor damage.
- 📖 Pr.01-35 to Pr.01-42 is the V/f curve for the motor 2. When multi-function input terminals Pr.02-01~02-08 and Pr.02-26 ~Pr.02-31 are set to 14 and enabled, the AC motor drive will act as the 2nd V/f curve.

The V/f curve for the motor 1 is shown as follows. The V/f curve for the motor 2 can be deduced from it.

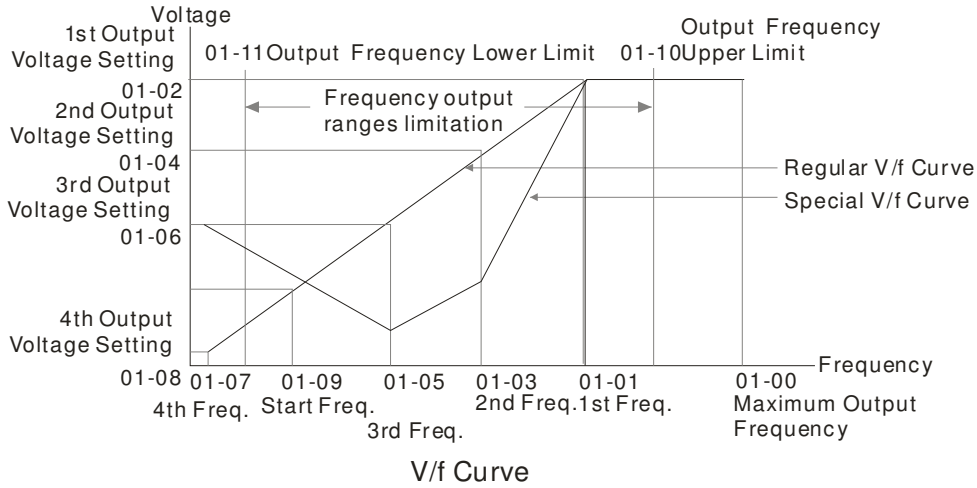

Common settings of V/f curve:

(1) General purpose

Motor spec. 60Hz

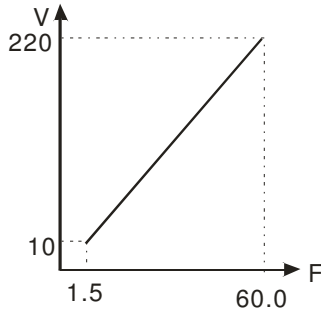

Pr.	Setting
01-00	60.0
01-01	60.0
01-02	220.0
01-03	1.50
01-05	1.50
01-04	10.0
01-06	10.0
01-07	1.50
01-08	10.0

Motor spec. 50Hz

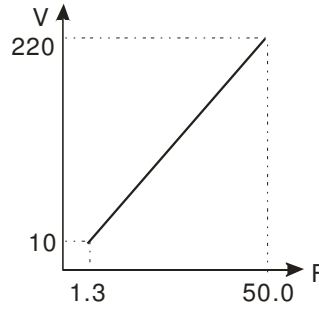

Pr.	Setting
01-00	50.0
01-01	50.0
01-02	220.0
01-03	1.30
01-05	1.30
01-04	12.0
01-06	12.0
01-07	1.30
01-08	12.0

(2) Fan and hydraulic machinery

Motor spec. 60Hz

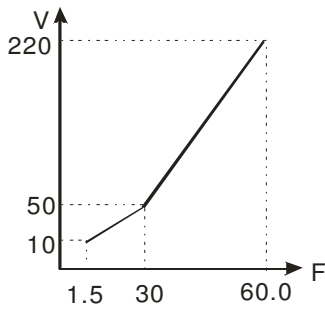

Pr.	Setting
01-00	60.0
01-01	60.0
01-02	220.0
01-03	30.0
01-05	30.0
01-04	50.0
01-06	50.0
01-07	1.50
01-08	10.0

Motor spec. 50Hz

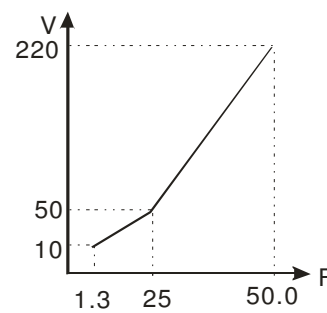

Pr.	Setting
01-00	50.0
01-01	50.0
01-02	220.0
01-03	25.0
01-05	25.0
01-04	50.0
01-06	50.0
01-07	1.30
01-08	10.0

(3) High starting torque

Motor spec. 60Hz

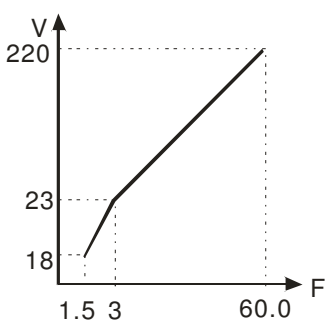

Pr.	Setting
01-00	60.0
01-01	60.0
01-02	220.0
01-03	3.00
01-05	3.00
01-04	23.0
01-06	23.0
01-07	1.50
01-08	18.0

Motor spec. 50Hz

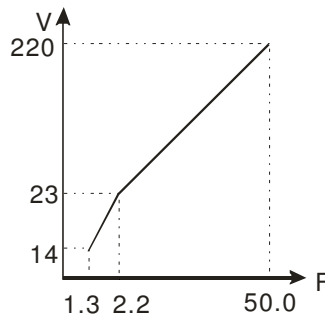

Pr.	Setting
01-00	50.0
01-01	50.0
01-02	220.0
01-03	2.20
01-05	2.20
01-04	23.0
01-06	23.0
01-07	1.30
01-08	14.0

01-09 Start-Up Frequency

Factory Setting: 0.50

Settings 0.0~600.00Hz

When start frequency is higher than the min. output frequency, drives' output will be from start frequency to the setting frequency. Please refer to the following diagram for details.

Fcmd=frequency command,

Fstart=start frequency (Pr.01-09),

fstart=actual start frequency of drive,

Fmin=4th output frequency setting (Pr.01-07/Pr.01-41),

Flow=output frequency lower limit (Pr.01-11)

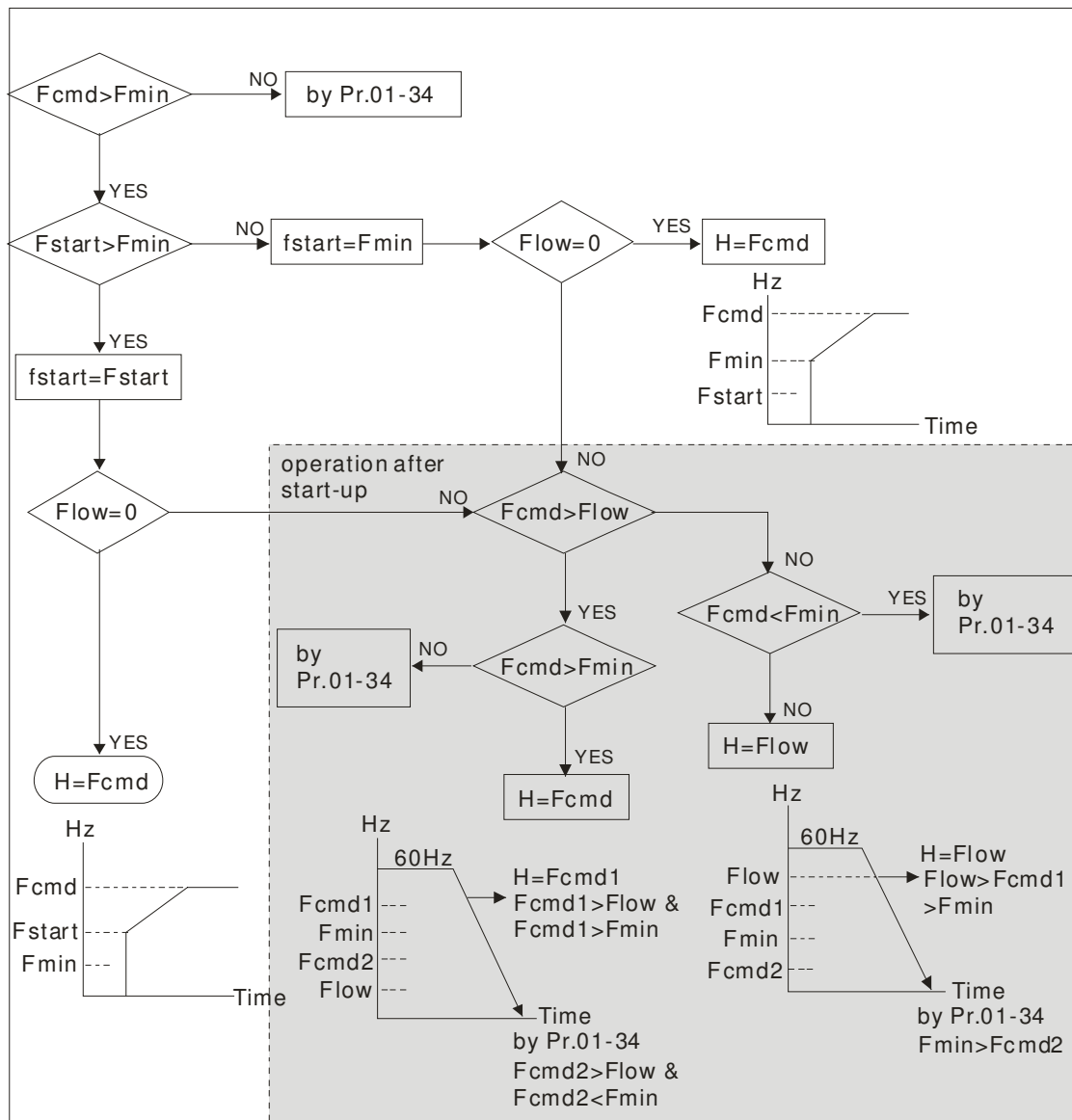
**01-10** Output Frequency Upper Limit

Factory Setting: 600.00

Settings 0.0~600.00Hz

01-11 Output Frequency Lower Limit

Factory Setting: 0.00

Settings 0.0~600.00Hz

- 📖 The upper/lower output frequency setting is used to limit the actual output frequency. If the frequency setting is higher than the upper limit, it will run with the upper limit frequency. If output frequency lower than output frequency lower limit and frequency setting is higher than min. frequency, it will run with lower limit frequency. The upper limit frequency should be set to be higher than the lower limit frequency.
- 📖 Pr.01-10 setting must be \geq Pr.01-11 setting. Pr.01-00 setting is regarded as 100.0%.
- 📖 Output frequency upper limit = $(Pr.01-00 \times Pr.01-10) / 100$
- 📖 This setting will limit the max. Output frequency of drive. If frequency setting is higher than Pr.01-10, the output frequency will be limited by Pr.01-10 setting.
- 📖 When the drive starts the function of slip compensation (Pr.07-27) or PID feedback control, drive output frequency may exceed frequency command but still be limited by this setting.
- 📖 Related parameters: Pr.01-00 Max. Operation Frequency and Pr.01-11 Output Frequency Lower Limit

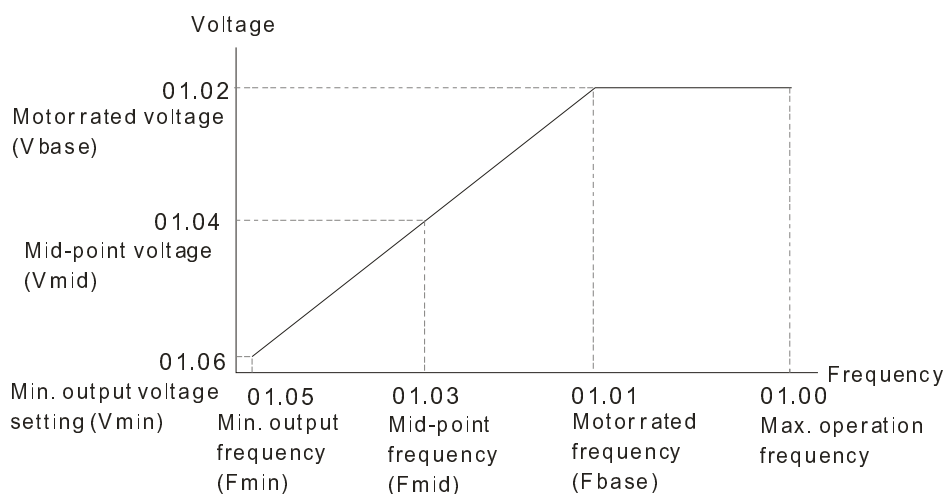

- 📖 This setting will limit the min. output frequency of drive. When drive frequency command or feedback control frequency is lower than this setting, drive output frequency will limit by the lower limit of frequency.
- 📖 When the drive starts, it will operate from min. output frequency (Pr.01-05) and accelerate to the setting frequency. It won't limit by this parameter setting.
- 📖 The setting of output frequency upper/lower limit is used to prevent personal disoperation, overheat due to too low operation frequency or damage due to too high speed.
- 📖 If the output frequency upper limit setting is 50Hz and frequency setting is 60Hz, max. output frequency will be 50Hz.
- 📖 If the output frequency lower limit setting is 10Hz and min. operation frequency setting (Pr.01-05) is 1.5Hz, it will operate by 10Hz when the frequency command is greater than Pr.01-05 and less than 10Hz. If the frequency command is less than Pr.01-05, the drive will be in ready status and no output.
- 📖 If the frequency output upper limit is 60Hz and frequency setting is also 60Hz, it won't exceed 60Hz even after slip compensation. If the output frequency needs to exceed 60Hz, it can increase output frequency upper limit or max. operation frequency.

⚡ **01-12** Accel. Time 1

⚡ **01-13** Decel. Time 1

↗	01-14	Accel. Time 2
↗	01-15	Decel. Time 2
↗	01-16	Accel. Time 3
↗	01-17	Decel. Time 3
↗	01-18	Accel. Time 4
↗	01-19	Decel. Time 4
↗	01-20	JOG Acceleration Time
↗	01-21	JOG Deceleration Time

Factory Setting: 10.00/10.0

Settings Pr.01-45=0: 0.00~600.00 seconds

Pr.01-45=1: 0.00~6000.00 seconds

- 📖 The Acceleration Time is used to determine the time required for the AC motor drive to ramp from 0Hz to Maximum Output Frequency (Pr.01-00).
- 📖 The Deceleration Time is used to determine the time require for the AC motor drive to decelerate from the Maximum Output Frequency (Pr.01-00) down to 0Hz.
- 📖 The Acceleration/Deceleration Time is invalid when using Pr.01-44 Optimal Acceleration/Deceleration Setting.
- 📖 The Acceleration/Deceleration Time 1, 2, 3, 4 are selected according to the Multi-function Input Terminals settings. The factory settings are Accel./Decel. time 1.
- 📖 When enabling torque limits and stalls prevention function, actual accel./decel. time will be longer than the above action time.
- 📖 Please note that it may trigger the protection function (Pr.06-03 Over-current Stall Prevention during Acceleration or Pr.06-01 Over-voltage Stall Prevention) when the setting of accel./decel. time is too short.
- 📖 Please note that it may cause motor damage or drive protection enabled due to over current during acceleration when the setting of acceleration time is too short.
- 📖 Please note that it may cause motor damage or drive protection enabled due to over current during deceleration or over-voltage when the setting of deceleration time is too short.
- 📖 It can use suitable brake resistor (see Chapter 07 Accessories) to decelerate in a short time and prevent over-voltage.
- 📖 When enabling Pr.01-24~Pr.01-27, the actual accel./decel. time will be longer than the setting.

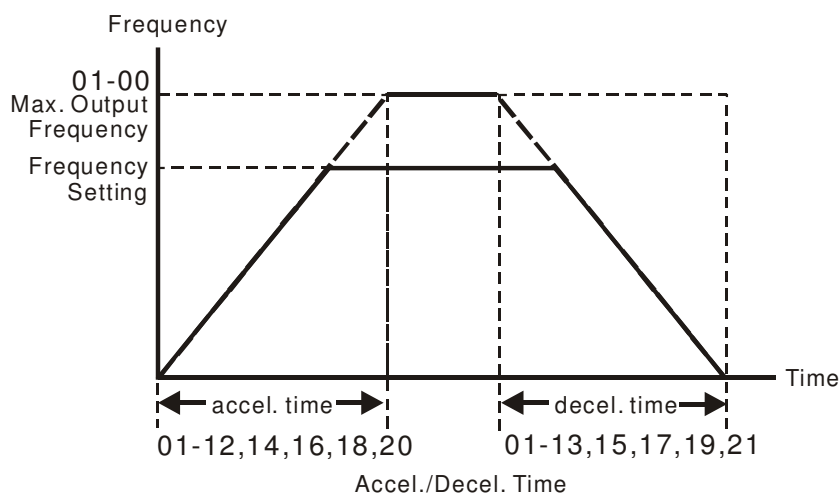

➤ **01-22** JOG Frequency

Factory Setting: 6.00

Settings 0.00~600.00Hz

- 📖 Both external terminal JOG and key “F1” on the keypad KPC-CC01 can be used. When the jog command is ON, the AC motor drive will accelerate from 0Hz to jog frequency (Pr.01-22). When the jog command is OFF, the AC motor drive will decelerate from Jog Frequency to zero. The Jog Accel./Decel. time (Pr.01-20, Pr.01-21) is the time that accelerates from 0.0Hz to Pr.01-22 JOG Frequency.
- 📖 The JOG command can't be executed when the AC motor drive is running. In the same way, when the JOG command is executing, other operation commands are invalid except forward/reverse commands and STOP key on the digital keypad.
- 📖 It does not support JOG function in the optional keypad KPC-CE01.

➤ **01-23** 1st/4th Accel./decel. Frequency

Factory Setting: 0.00

Settings 0.00~600.00Hz

- 📖 The transition from acceleration/deceleration time 1 to acceleration/deceleration time 4, may also be enabled by the external terminals. The external terminal has priority over Pr. 01-23.

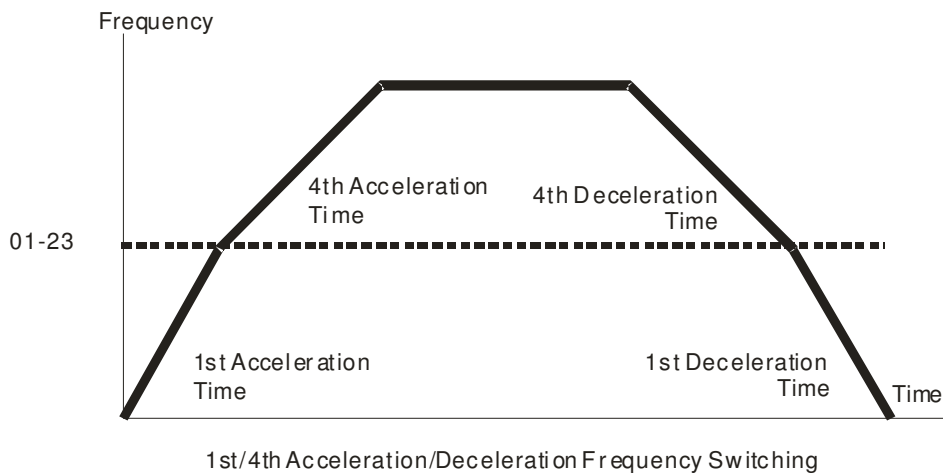

➤ **01-24** S-curve Acceleration Begin Time 1

➤ **01-25** S-curve Acceleration Arrival Time 2

➤ **01-26** S-curve Deceleration Begin Time 1

➤ **01-27** S-curve Deceleration Arrival Time 2

Factory Setting: 0.20/0.2

Settings Pr.01-45=0: 0.00~25.00 seconds
Pr.01-45=1: 0.00~250.0 seconds

- 📖 It is used to give the smoothest transition between speed changes. The accel./decel. curve can adjust the S-curve of the accel./decel. When it is enabled, the drive will have different accel./decel. curve by the accel./decel. time.
- 📖 The S-curve function is disabled when accel./decel. time is set to 0.
- 📖 When Pr.01-12, 01-14, 01-16, 01-18 ≥ Pr.01-24 and Pr.01-25,
The Actual Accel. Time = Pr.01-12, 01-14, 01-16, 01-18 + (Pr.01-24 + Pr.01-25)/2

When Pr.01-13, 01-15, 01-17, 01-19 \geq Pr.01-26 and Pr.01-27,

The Actual Decel. Time = Pr.01-13, 01-15, 01-17, 01-19 + (Pr.01-26 + Pr.01-27)/2

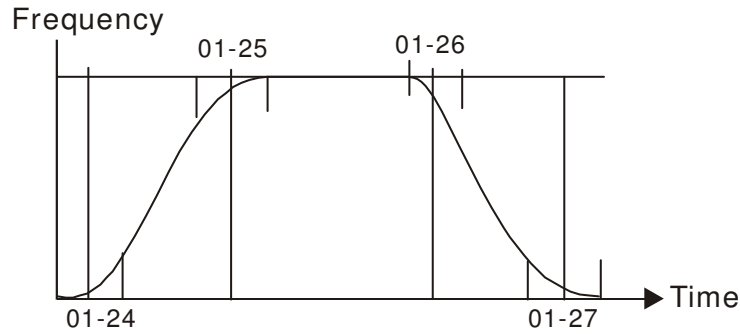

01-28 Skip Frequency 1 (upper limit)

01-29 Skip Frequency 1 (lower limit)

01-30 Skip Frequency 2 (upper limit)

01-31 Skip Frequency 2 (lower limit)

01-32 Skip Frequency 3 (upper limit)

01-33 Skip Frequency 3 (lower limit)

Factory Setting: 0.00

Settings 0.00~600.00Hz

- These parameters are used to set the skip frequency of the AC drive. But the frequency output is continuous. There is no limit for the setting of these six parameters and can be used as required.
- The skip frequencies are useful when a motor has vibration at a specific frequency bandwidth. By skipping this frequency, the vibration will be avoided. It offers 3 zones for use.
- These parameters are used to set the skip frequency of the AC drive. But the frequency output is continuous. The limit of these six parameters is 01-28 \geq 01-29 \geq 01-30 \geq 01-31 \geq 01-32 \geq 01-33. This function will be invalid when setting to 0.0.
- The setting of frequency command (F) can be set within the range of skip frequencies. In this moment, the output frequency (H) will be limited by these settings.
- When accelerating/decelerating, the output frequency will still pass the range of skip frequencies.

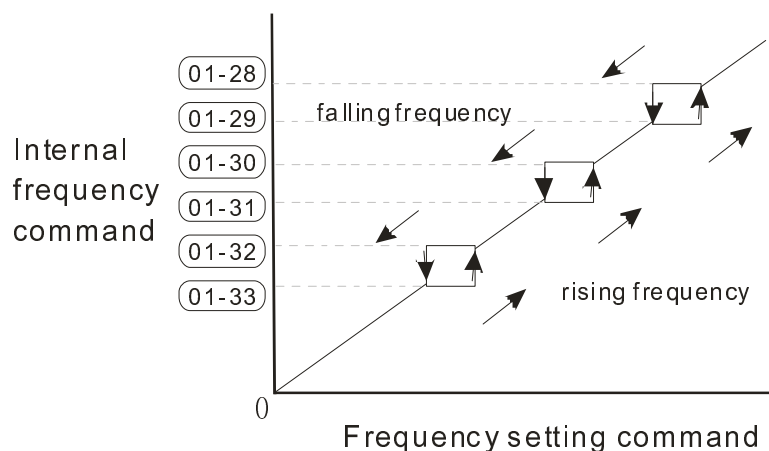

01-34 Zero-speed Mode

Factory Setting: 0

- Settings 0: Output waiting
 1: Zero-speed operation
 2: Fmin (4th output frequency setting)

- 📖 When the frequency is less than Fmin (Pr.01-07 or Pr.01-41), it will operate by this parameter.
- 📖 When it is set to 0, the AC motor drive will be in waiting mode without voltage output from terminals U/V/W.
- 📖 When setting 1, it will execute DC brake by Vmin. (Pr.01-08 and Pr.01-42) in V/f, VFPG and SVC modes. It executes zero-speed operation in VFPG and FOCPG mode.
- 📖 When it is set to 2, the AC motor drive will run by Fmin (Pr.01-07, Pr.01-41) and Vmin (Pr.01-08, Pr.01-42) in V/f, VFPG, SVC and FOCPG modes.
- 📖 In V/f, VFPG and SVC modes

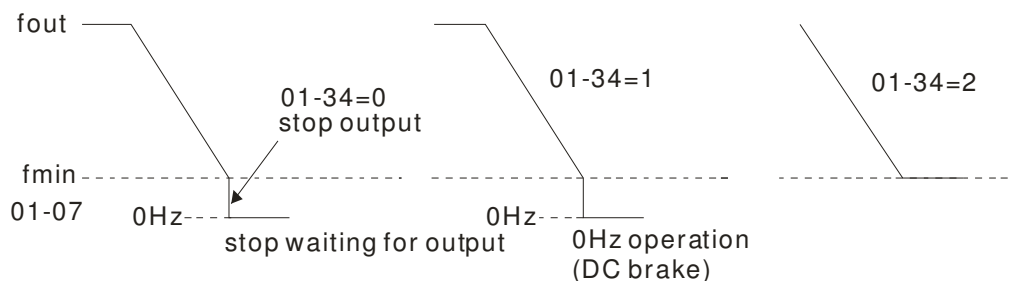

- 📖 In FOCPG mode, when Pr.01-34 is set to 2, it will act according Pr.01-34 setting.

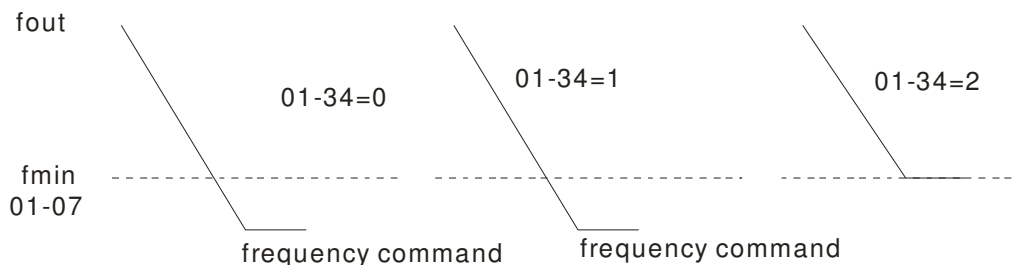
**01-43** V/f Curve Selection

Factory Setting: 0

- Settings 0: V/f curve determined by group 01
 1: 1.5 power curve
 2: Square curve

- 📖 When setting to 0, refer to Pr.01-01~01-08 for motor 1 V/f curve. For motor 2, please refer to Pr.01-35~01-42.
- 📖 When setting to 1 or 2, 2nd and 3rd voltage frequency setting are invalid.
- 📖 If motor load is variable torque load (torque is in direct proportion to speed, such as the load of fan or pump), it can decrease input voltage to reduce flux loss and iron loss of the motor at low speed with low load torque to raise the entire efficiency.
- 📖 When setting higher power V/f curve, it is lower torque at low frequency and is not suitable for rapid acceleration/deceleration. It is recommended Not to use this parameter for the rapid acceleration/deceleration.

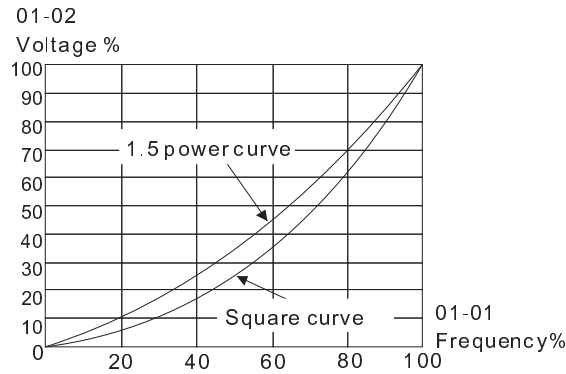

01-44 Optimal Acceleration/Deceleration Setting

Factory Setting: 0

Settings 0: Linear accel./decel.

1: Auto accel., linear decel.

2: Linear accel., auto decel.

3: Auto accel./decel. (auto calculate the accel./decel. time by actual load)

4: Stall prevention by auto accel./decel. (limited by 01-12 to 01-21)

- 📖 Pr.01-44 is used to reduce the drive's vibration during load starts and stops. Also it will speed up to the setting frequency with the fastest and smoothest start-up current when it detects small torque. At deceleration, it will auto stop the drive with the fastest and the smoothest deceleration time when the regenerated voltage of the load is detected.
- 📖 Setting 0 Linear accel./decel.: it will accelerate/decelerate according to the setting of Pr.01-12~01-19.
- 📖 Setting to Auto accel./decel.: it can reduce the mechanical vibration and prevent the complicated auto-tuning processes. It won't stall during acceleration and no need to use brake resistor. In addition, it can improve the operation efficiency and save energy.
- 📖 Setting 3 Auto accel./decel. (auto calculate the accel./decel. time by actual load): it can auto detect the load torque and accelerate from the fastest acceleration time and smoothest start current to the setting frequency. In the deceleration, it can auto detect the load re-generation and stop the motor smoothly with the fastest decel. time.
- 📖 Setting 4 Stall prevention by auto accel./decel. (limited by 01-12 to 01-21): if the acceleration/deceleration is in the reasonable range, it will accelerate/decelerate by Pr.01-12~01-19. If the accel./decel. time is too short, the actual accel./decel. time is greater than the setting of accel./decel. time.

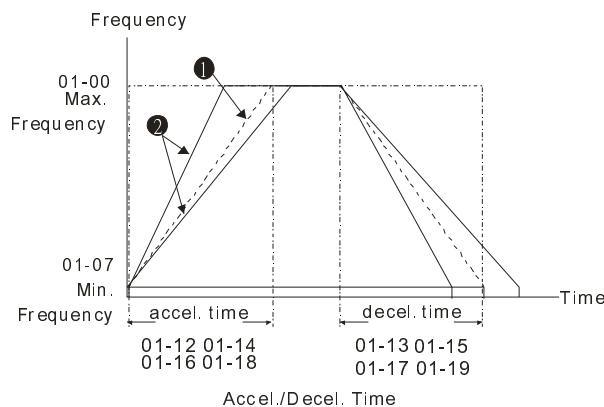

① When Pr.01-44 is set to 0.

② When Pr.01-44 is set to 3.

01-45 Time Unit for Acceleration/Deceleration and S Curve

Factory Setting: 0

Settings 0: Unit 0.01 sec
1: Unit 0.1 sec

01-46 Time for CANopen Quick Stop

Factory Setting: 1.00

Settings Pr. 01-45=0: 0.00~600.00 sec
Pr. 01-45=1: 0.0~6000.0 sec

 It is used to set the time that decelerates from the max. operation frequency (Pr.01-00) to 0.00Hz in CANopen control

02 Digital Input/Output Parameter

✎ This parameter can be set during operation.

02-00 2-wire/3-wire Operation Control

Factory Setting: 0

Settings 0: 2 wire mode 1
1: 2 wire mode 2
2: 3 wire mode

📖 It is used to set the operation control method:

Pr.02-00	Control Circuits of the External Terminal
Set as 0 2-wire mode 1 FWD/STOP REV/STOP	
Set as 1 2-wire mode 2 RUN/STOP FWD/REV REV/FWD	
Set as 3 3-wire operation control	

01-18 Multi-function Input Command 1 (MI1)

(MI1= STOP command when in 3-wire operation control)

Factory Setting: 1

02-02 Multi-function Input Command 2 (MI2)

Factory Setting: 2

02-03 Multi-function Input Command 3 (MI3)

Factory Setting: 3

02-04 Multi-function Input Command 4 (MI4)

Factory Setting: 4

02-05 Multi-function Input Command 5 (MI5)

02-06 Multi-function Input Command 6 (MI6)

02-07 Multi-function Input Command 7 (MI7)

02-08 Multi-function Input Command 8 (MI8)

Factory Setting: 0

Settings

0: no function
1: multi-step speed command 1/multi-step position command 1
2: multi-step speed command 2/multi-step position command 2
3: multi-step speed command 3/multi-step position command 3

- 4: multi-step speed command 4/multi-step position command 4
- 5: Reset
- 6: JOG command (By KPC-CC01 or external control)
- 7: acceleration/deceleration speed not allow
- 8: the 1st, 2nd acceleration/deceleration time selection
- 9: the 3rd, 4th acceleration/deceleration time selection
- 10: EF Input (Pr.07-20)
- 11: B.B input from external (Base Block)
- 12: Output stop
- 13: cancel the setting of the optimal acceleration/deceleration time
- 14: switch between motor 1 and motor 2
- 15: operation speed command from AVI
- 16: operation speed command from ACI
- 17: operation speed command from AUI
- 18: Emergency stop (Pr.07-20)
- 19: Digital up command
- 20: Digital down command
- 21: PID function disabled
- 22: Clear counter
- 23: Input the counter value (MI6)
- 24: FWD JOG command
- 25: REV JOG command
- 26: FOCG/TQC model selection
- 27: ASR1/ASR2 selection
- 28: Emergency stop (EF1)
- 29: Signal confirmation for Y-connection
- 30: Signal confirmation for Δ -connection
- 31: High torque bias (Pr.11-30)
- 32: Middle torque bias (Pr.11-31)
- 33: Low torque bias (Pr.11-32)
- 34: Switch between multi-step position and multi-speed control
- 35: Enable position control
- 36: Enable multi-step position learning function (valid at stop)
- 37: Enable pulse position input command
- 38: Disable write EEPROM function
- 39: Torque command direction
- 40: Force coast to stop
- 41: HAND switch
- 42: AUTO switch
- 43~47: Reserved
- 48: Mechanical gear ratio switch
- 49: Drive enable
- 50: Master dEb action input
- 51: Selection for PLC mode bit0
- 52: Selection for PLC mode bit1
- 53: Trigger CANopen quick stop
- 54~55: Reserved
- 56: Local/Remote Selection

 This parameter selects the functions for each multi-function terminal.

- 📖 The terminals of Pr.02-26~Pr.02-29 are virtual and set as MI10~MI13 when using with optional card EMC-D42A. Pr.02-30~02-31 are virtual terminals.
- 📖 When being used as a virtual terminal, it needs to change the status (0/1: ON/OFF) of bit 8-15 of Pr.02-12 by digital keypad KPC-CC01 or communication.
- 📖 If Pr.02-00 is set to 3-wire operation control. Terminal MI1 is for STOP contact. Therefore, MI1 is not allowed for any other operation.
- 📖 Summary of function settings (Take the normally open contact for example, ON: contact is closed, OFF: contact is open)

Settings	Functions	Descriptions
0	No Function	
1	Multi-step speed command 1/multi-step position command 1	15 step speeds could be conducted through the digital status of the 4 terminals, and 16 in total if the master speed is included. (Refer to Parameter set 4)
2	Multi-step speed command 2/ multi-step position command 2	
3	Multi-step speed command 3/ multi-step position command 3	
4	Multi-step speed command 4/ multi-step position command 4	
5	Reset	After the error of the drive is eliminated, use this terminal to reset the drive.
6	JOG Command	<p>Before executing this function, it needs to wait for the drive stop completely. During running, it can change the operation direction and STOP key on the keypad is valid. Once the external terminal receives OFF command, the motor will stop by the JOG deceleration time. Refer to Pr.01-20~01-22 for details.</p>
7	Acceleration/deceleration Speed Inhibit	<p>When this function is enabled, acceleration and deceleration is stopped. After this function is disabled, the AC motor drive starts to accel./decel. from the inhibit point.</p>

Settings	Functions	Descriptions
8	The 1 st , 2 nd acceleration or deceleration time selection	The acceleration/deceleration time of the drive could be selected from this function or the digital status of the terminals; there are 4 acceleration/deceleration speeds in total for selection.
9	The 3 rd , 4 th acceleration or deceleration time selection	
10	EF Input (EF: External fault)	External fault input terminal. It will decelerate by Pr.07-20 setting (it will have fault record when external fault occurs)
11	External B.B. Input (Base Block)	When this contact is ON, output of the drive will be cut off immediately, and the motor will be free run and display B.B. signal. Refer to Pr.07-08 for details.
12	Output Stop	<p>If this contact is ON, output of the drive will be cut off immediately, and the motor will then be free run. And once it is turned to OFF, the drive will accelerate to the setting frequency.</p> <p>Mlx-GND ON OFF ON</p> <p>Operation command ON</p>
13	Cancel the setting of the optimal accel./decel. time	Before using this function, Pr.01-44 should be set to 01/02/03/04 first. When this function is enabled, OFF is for auto mode and ON is for linear accel./decel.
14	Switch between drive settings 1 and 2	When the contact is ON: use motor 2 parameters. OFF: use motor 1 parameters.
15	Operation speed command form AVI	When the contact is ON, the source of the frequency will force to be AVI. (If the operation speed commands are set to AVI, ACI and AUI at the same time. The priority is AVI>ACI>AUI)
16	Operation speed command form ACI	When the contact is ON, the source of the frequency will force to be ACI. (If the operation speed commands are set to AVI, ACI and AUI at the same time. The priority is AVI>ACI>AUI)
17	Operation speed command form AUI	When this function is enabled, the source of the frequency will force to be AUI. (If the operation speed commands are set to AVI, ACI and AUI at the same time. The priority is AVI>ACI>AUI)
18	Emergency Stop (07-20)	When the contact is ON, the drive will ramp to stop by Pr.07-20 setting.
19	Digital Up command	When the contact is ON, the frequency will be increased and decreased. If this function is constantly ON, the frequency will be increased/decreased by Pr.02-09/Pr.02-10.
20	Digital Down command	
21	PID function disabled	When the contact is ON, the PID function is disabled.
22	Clear counter	When the contact is ON, it will clear current counter value and display "0". Only when this function is disabled, it will keep counting upward.
23	Input the counter value (multi-function input command 6)	The counter value will increase 1 once the contact is ON. It needs to be used with Pr.02-19.

Settings	Functions	Descriptions
24	FWD JOG command	When the contact is ON, the drive will execute forward Jog command. When execute JOG command under torque mode, the drive will automatically switch to speed mode; after JOG command is done, the drive will return to torque mode.
25	REV JOG command	When the contact is ON the drive will execute reverse Jog command. When execute JOG command under torque mode, the drive will automatically switch to speed mode; after JOG command is done, the drive will return to torque mode.
26	FOCPG/TQCPG mode selection	<p>When the contact is ON: TQCPG mode. When the contact is OFF: FOCPG mode.</p> <p>03-00-02=1 (AVI/AUI/ACI is frequency command) 03-00-02=2 (AVI/AUI/ACI is torque command)</p> <p>control mode: speed control, torque control, speed control, torque control, speed control (decel. to stop)</p> <p>Switch timing for torque/speed control (00-10=0/4, multi-function input terminal is set to 26)</p>
27	ASR1/ASR2 selection	When the contact is ON: speed will be adjusted by ASR 2 setting. OFF: speed will be adjusted by ASR 1 setting. Refer to Pr.11-02 for details.
28	Emergency stop (EF1)	<p>When the contact is ON, the drive will execute emergency stop and display EF1 on the keypad. The motor won't run and be in the free run until the fault is cleared after pressing RESET" (EF: External Fault)</p> <p>Voltage Frequency Setting frequency Time Mix-GND Reset Operation command</p>
29	Signal confirmation for Y-connection	When is the contact is ON, the drive will operate by 1st V/f.
30	Signal confirmation for Δ-connection	When the contact is ON, the drive will operate by 2nd V/f.
31	High torque bias	Refer to Pr.11-30~11-32 for details.
32	Middle torque bias	
33	Low torque bias	
34~37	Reserved	

Settings	Functions	Descriptions															
38	Disable EEPROM write function	When this contact is ON, write to EEPROM is disabled.															
39	Torque command direction	For torque control (Pr.00-10=2), when torque command is AVI or ACI, the contact is ON and it is negative torque.															
40	Force coast to stop	When this contact is ON during the operation, the drive will free run to stop.															
41	HAND switch	1. When MI is switched to off status, it executes a STOP command. , If MI is switched to off during operation, the drive will also stop.															
42	AUTO switch	2. Using keypad KPC-CC01 to switch between HAND/AUTO, the drive will stop first then switch to the HAND or AUTO status. 3. On the digital keypad KPC-CC01, it will display current drive status (HAND/OFF/AUTO). <table border="1" style="margin-left: auto; margin-right: auto;"> <thead> <tr> <th></th> <th>bit 1</th> <th>bit 0</th> </tr> </thead> <tbody> <tr> <td>OFF</td> <td>0</td> <td>0</td> </tr> <tr> <td>AUTO</td> <td>0</td> <td>1</td> </tr> <tr> <td>HAND</td> <td>1</td> <td>0</td> </tr> <tr> <td>OFF</td> <td>1</td> <td>1</td> </tr> </tbody> </table>		bit 1	bit 0	OFF	0	0	AUTO	0	1	HAND	1	0	OFF	1	1
	bit 1	bit 0															
OFF	0	0															
AUTO	0	1															
HAND	1	0															
OFF	1	1															
43~47	Reserved																
48	Mechanical gear ratio switch	When this contact is ON, the mechanical gear ratio switch will be the second group A2/B2 (refer to Pr.10-08 and Pr.10-09).															
49	Drive enable	When drive=enable, RUN command is valid. When drive= disable, RUN command is invalid. When drive is in operation, motor coast to stop.															
50	Master dEb action input	Input the message setting in this parameter when dEb occurs to Master. This will ensure dEb also occurs to Slave, then Master and Slave will stop simultaneously.															
51	Selection for PLC mode bit0	<table border="1" style="margin-left: auto; margin-right: auto;"> <thead> <tr> <th>PLC status</th> <th>bit 1</th> <th>bit 0</th> </tr> </thead> <tbody> <tr> <td>Disable PLC function (PLC 0)</td> <td>0</td> <td>0</td> </tr> <tr> <td>Trigger PLC to operation (PLC 1)</td> <td>0</td> <td>1</td> </tr> <tr> <td>Trigger PLC to stop (PLC 2)</td> <td>1</td> <td>0</td> </tr> <tr> <td>No function</td> <td>1</td> <td>1</td> </tr> </tbody> </table>	PLC status	bit 1	bit 0	Disable PLC function (PLC 0)	0	0	Trigger PLC to operation (PLC 1)	0	1	Trigger PLC to stop (PLC 2)	1	0	No function	1	1
PLC status	bit 1		bit 0														
Disable PLC function (PLC 0)	0	0															
Trigger PLC to operation (PLC 1)	0	1															
Trigger PLC to stop (PLC 2)	1	0															
No function	1	1															
52	Selection for PLC mode bit1																
53	Enable CANopen quick stop	When this function is enabled under CANopen control, it will change to quick stop. Refer to Chapter 15 for more details.															
54~55	Reserved																
56	LOCAL/REMOTE Selection	Use Pr.00-29 to select for LOCAL/REMOTE mode(refer to Pr.00-29) When Pr.00-29 is not set to 0, on the digital keypad KPC-CC01 it will display LOC/REM status. (It will display on the KPC-CC01 if the firmware version is above version 1.021). <table border="1" style="margin-left: auto; margin-right: auto;"> <thead> <tr> <th></th> <th>bit 0</th> </tr> </thead> <tbody> <tr> <td>REM</td> <td>0</td> </tr> <tr> <td>LOC</td> <td>1</td> </tr> </tbody> </table>		bit 0	REM	0	LOC	1									
	bit 0																
REM	0																
LOC	1																

02-09 UP/DOWN Key Mode

Factory Setting: 0

- Settings 0: Up/down by the accel/decel time
1: Up/down constant speed (Pr.02-10)

02-10 Constant speed. The Accel. /Decel. Speed of the UP/DOWN Key

Factory Setting: 0.01

- Settings 0.01~1.00Hz/ms

These settings are used when multi-function input terminals are set to 19/20. Refer to Pr.02-09 and 02-10 for the frequency up/down command.

Pr.02-09 set to 0: it will increase/decrease frequency command (F) by the external terminal UP/DOWN key as shown in the following diagram. In this mode, it also can be controlled by UP/DOWN key on the digital keypad.

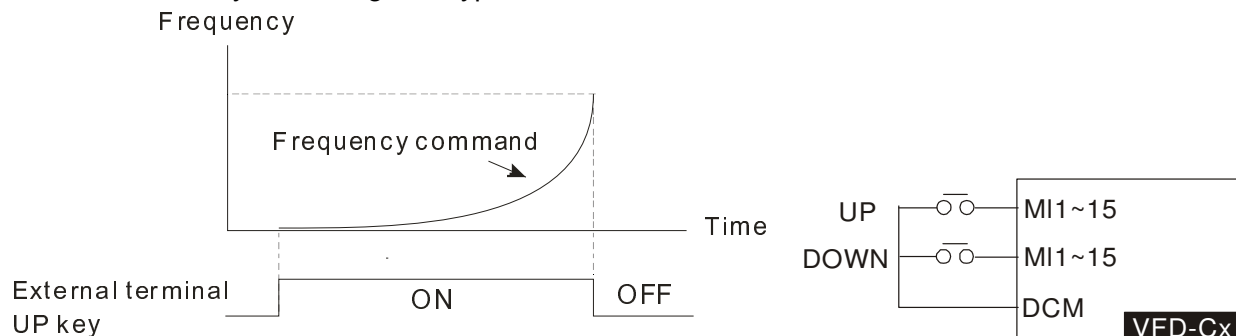

Pr.02-09 set to 1: it will increase/decrease frequency command (F) by the setting of acceleration/deceleration (Pr.01-12~01-19) and only be valid during operation.

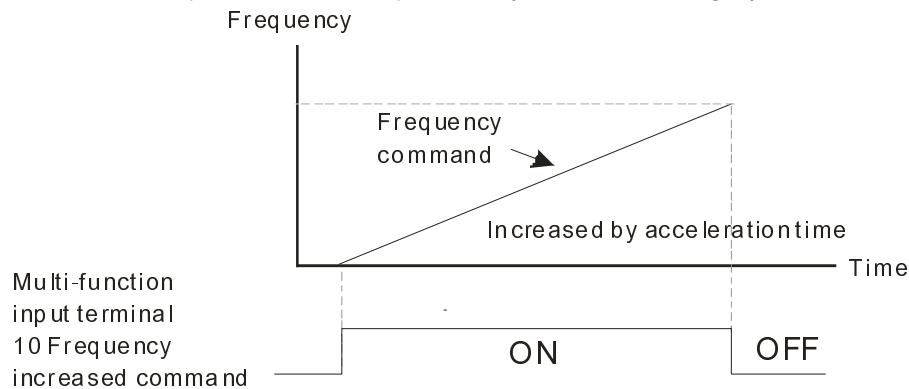

02-11 Digital Input Response Time

Factory Setting: 0.005

- Settings 0.000~30.000 sec

This parameter is used to set the response time of digital input terminals FWD, REV and MI1~MI8.

It is used for digital input terminal signal delay and confirmation. The delay time is confirmation time to prevent some uncertain interference that would cause error in the input of the digital terminals. Under this condition, confirmation for this parameter would improve effectively, but the response time will be somewhat delayed.

02-12 Digital Input Operation Direction

Factory Setting: 0000h

- Settings 0000h~FFFFh (0:N.O. ; 1:N.C.)

The setting of this parameter is In hexadecimal.

📖 This parameter is used to set the input signal level and it won't be affected by the SINK/SOURCE status.

📖 Bit0 is for FWD terminal, bit1 is for REV terminal and bit2 to bit15 is for MI1 to MI14.

📖 User can change terminal status by communicating.

For example, MI1 is set to 1 (multi-step speed command 1), MI2 is set to 2 (multi-step speed command 2). Then the forward + 2nd step speed command=1001(binary)=9 (Decimal). Only need to set Pr.02-12=9 by communication and it can forward with 2nd step speed. It doesn't need to wire any multi-function terminal.

bit9	bit8	bit7	bit6	bit5	bit4	bit3	bit2	bit1	bit0
MI8	MI7	MI6	MI5	MI4	MI3	MI2	MI1	REV	FWD

- ↗ **02-13** Multi-function Output 1 (Relay1) Factory Setting: 11
- ↗ **02-14** Multi-function Output 2 (Relay2) Factory Setting: 1
- ↗ **02-16** Multi-function Output 3 (MO1) When Pr02-21 =0, this parameter is enabled.
- ↗ **02-17** Multi-function Output 4 (MO2) When Pr02-55 =0, this parameter is enabled. Factory Setting: 0

Settings

- 0: No function
- 1: Operation Indication
- 2: Operation speed attained
- 3: Desired frequency attained 1 (Pr.02-22)
- 4: Desired frequency attained 2 (Pr.02-24)
- 5: Zero speed (Frequency command)
- 6: Zero speed, include STOP(Frequency command)
- 7: Over torque 1(Pr.06-06~06-08)
- 8: Over torque 2(Pr.06-09~06-11)
- 9: Drive is ready
- 10: Low voltage warning (LV) (Pr.06-00)
- 11: Malfunction indication
- 12: Mechanical brake release(Pr.02-32)
- 13: Overheat warning (Pr.06-15)
- 14: Software brake signal indication(Pr.07-00)
- 15: PID feedback error
- 16: Slip error (oSL)
- 17: Terminal count value attained (Pr.02-20; not return to 0)
- 18: Preliminary count value attained (Pr.02-19; returns to 0)
- 19: Base Block
- 20: Warning output
- 21: Over voltage warning

- 22: Over-current stall prevention warning
- 23: Over-voltage stall prevention warning
- 24: Operation mode indication
- 25: Forward command
- 26: Reverse command
- 27: Output when current \geq Pr.02-33 (\geq 02-33)
- 28: Output when current \leq Pr.02-33 (\leq 02-33)
- 29: Output when frequency \geq Pr.02-34 (\geq 02-34)
- 30: Output when frequency \leq Pr.02-34 (\leq 02-34)
- 31: Y-connection for the motor coil
- 32: Δ -connection for the motor coil
- 33: Zero speed (actual output frequency)
- 34: Zero speed include stop(actual output frequency)
- 35: Error output selection 1(Pr.06-23)
- 36: Error output selection 2(Pr.06-24)
- 37: Error output selection 3(Pr.06-25)
- 38: Error output selection 4(Pr.06-26)
- 39: Reserved
- 40: Speed attained (including Stop)
- 41: Reserved
- 42: Crane function
- 43: Actual motor speed slower than Pr.02-47
- 44: Low current output (Pr.06-71 to Pr.06-73)
- 45: Reserved
- 46: Master dEb action output
- 47: Closed brake output
- 48~49: Reserved
- 50: Output for CANopen control
- 51: Output for RS-485
- 52~66: Reserved
- 67: Analog input signal level achieved

 This parameter is used for setting the function of multi-function terminals.

 Summary of function settings (Take the normally open contact for example, ON: contact is closed, OFF: contact is open)

Settings	Functions	Descriptions
0	No Function	
1	Operation Indication	Active when the drive is not at STOP.
2	Master Frequency Attained	Active when the AC motor drive reaches the output frequency setting.
3	Desired Frequency Attained 1 (Pr.02-22)	Active when the desired frequency (Pr.02-22) is attained.
4	Desired Frequency Attained 2 (Pr.02-24)	Active when the desired frequency (Pr.02-24) is attained.

Settings	Functions	Descriptions
5	Zero Speed (frequency command)	Active when frequency command =0. (the drive should be at RUN mode)
6	Zero Speed with Stop (frequency command)	Active when frequency command =0 or stop.
7	Over Torque 1	Active when detecting over-torque. Refer to Pr.06-07 (over-torque detection level-OT1) and Pr.06-08 (over-torque detection time-OT1). Refer to Pr.06-06~06-08.
8	Over Torque 2	Active when detecting over-torque. Refer to Pr.06-10 (over-torque detection level-OT2) and Pr.06-11 (over-torque detection time-OT2). Refer to Pr.06-09~06-11.
9	Drive Ready	Active when the drive is ON and no abnormality detected.
10	Low voltage warn (Lv)	Active when the DC Bus voltage is too low. (refer to Pr.06-00 low voltage level)
11	Malfunction Indication	Active when fault occurs (except Lv stop).
12	Mechanical Brake Release (Pr.02-32)	When drive runs after Pr.02-32, it will be ON. This function should be used with DC brake and it is recommended to use contact "b"(N.C).
13	Overheat	Active when IGBT or heat sink overheats to prevent OH turn off the drive. (refer to Pr.06-15)
14	Software Brake Signal Indication	Active when the soft brake function is ON. (refer to Pr.07-00)
15	PID Feedback Error	Active when the feedback signal is abnormal.
16	Slip Error (oSL)	Active when the slip error is detected.
17	Terminal Count Value Attained (Pr.02-20; not return to 0)	Active when the counter reaches Terminal Counter Value (Pr.02-19). This contact won't active when Pr.02-20>Pr.02-19.
18	Preliminary Counter Value Attained (Pr.02-19; returns to 0)	Active when the counter reaches Preliminary Counter Value (Pr.02-19).
19	External Base Block input (B.B.)	Active when the output of the AC motor drive is shut off during base block.
20	Warning Output	Active when the warning is detected.
21	Over-voltage Warning	Active when the over-voltage is detected.
22	Over-current Stall Prevention Warning	Active when the over-current stall prevention is detected.
23	Over-voltage Stall prevention Warning	Active when the over-voltage stall prevention is detected.
24	Operation Mode Indication	Active when the operation command is controlled by external terminal. (Pr.00-20≠0)
25	Forward Command	Active when the operation direction is forward.
26	Reverse Command	Active when the operation direction is reverse.
27	Output when Current >= Pr.02-33	Active when current is >= Pr.02-33.
28	Output when Current <= Pr.02-33	Active when current is <= Pr.02-33.

Settings	Functions	Descriptions
29	Output when frequency \geq Pr.02-34	Active when frequency is \geq Pr.02-34.
30	Output when Frequency \leq Pr.02-34	Active when frequency is \leq Pr.02-34.
31	Y-connection for the Motor Coil	Active when PR.05-24 is less than Pr.05-23 and time is more than Pr.05-25.
32	Δ -connection for the Motor Coil	Active when PR.05-24 is higher than Pr.05-23 and time is more than Pr.05-25.
33	Zero Speed (actual output frequency)	Active when the actual output frequency is 0. (the drive should be at RUN mode)
34	Zero Speed with Stop (actual output frequency)	Active when the actual output frequency is 0 or Stop.
35	Error Output Selection 1 (Pr.06-23)	Active when Pr.06-23 is ON.
36	Error Output Selection 2 (Pr.06-24)	Active when Pr.06-24 is ON.
37	Error Output Selection 3 (Pr.06-25)	Active when Pr.06-25 is ON.
38	Error Output Selection 4 (Pr.06-26)	Active when Pr.06-26 is ON.
39	Reserved	
40	Speed Attained (including zero speed)	Active when the output frequency reaches frequency setting or stop.
41	Reserved	
42	Crane Function	This function should be used with Pr.02-32, Pr.02-33 and Pr.02-34. Active when setting Pr.07-16=Pr.02-34 and Fcmd $>$ Pr.02-34 and output current $>$ Pr.02-33 and Time $>$ Pr.02-32. The example of the crane application is in the following for your reference.
43	Motor Zero-speed Output (Pr.02-47)	Active when motor actual speed is less than Pr.02-47.
44	Low Current Output	This function needs to be used with Pr.06-71 ~ Pr.06-73
45	Reserved	
46	Master dEb signal output	When dEb arise at Master, MO will send a dEb signal to Slave. Then Slave will follow Master's command and decelerate to stop simultaneously.
47	Brake Release at Stop	<p>When drive stops, the corresponding multi-function terminal will be ON if the frequency is less than Pr.02-34. After it is ON, it will be OFF when brake delay time exceeds Pr.02-32.</p>

Settings	Functions	Descriptions
48~49	Reserved	
50	Output for CANopen control	For CANopen communication output
51	Output for RS-485	For RS-485 output
52~66	Reserved	
67	Analog Input Signal Level Achieved	Active when AI input level is higher than Pr.03-45 AI upper level. MO shuts off when the AI input is lower than Pr.03-46 AI lower level.

Example: Crane Application

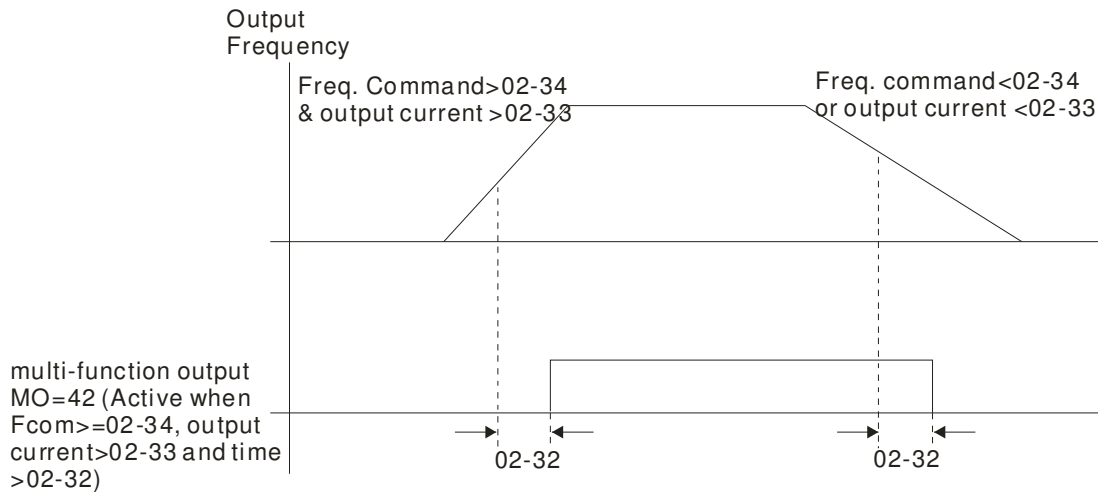

It is recommended to be used with Dwell function as shown in the following:

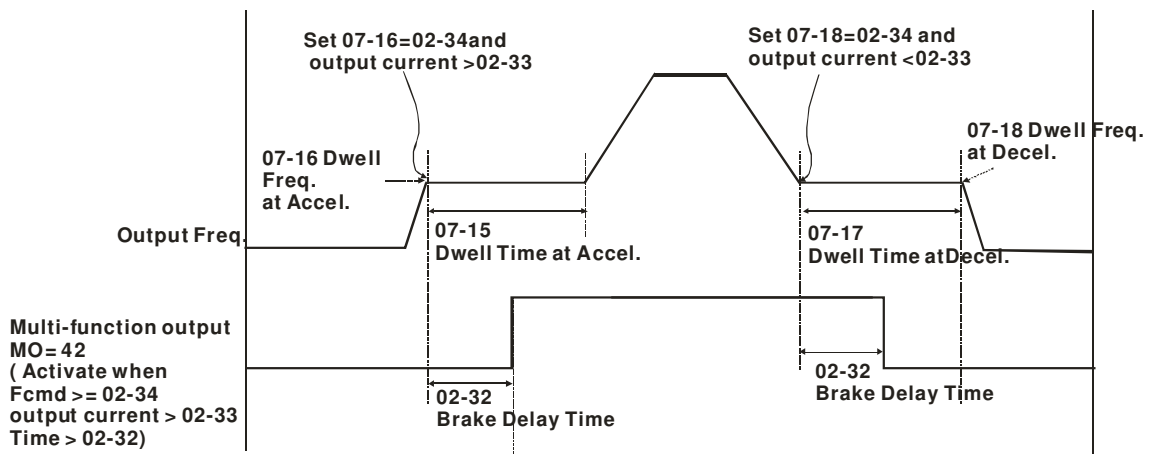

02-15 Reserved

✎ **02-18** Multi-function Output Direction

Factory Setting: 0000h

Settings 0000h~FFFFh (0:N.O. ; 1:N.C.)

- 📖 The setting of this parameter is in hexadecimal.
- 📖 This parameter is set via bit setting. If a bit is 1, the corresponding output acts in the opposite way.
- 📖 Bit setting

bit4	bit3	bit2	bit1	bit0
DFM2	DFM1	Reserved	RY2	RY1

02-19 Terminal Counting Value Attained (return to 0)

Factory Setting: 0

Settings 0~65500

- The counter trigger can be set by the multi-function terminal MI6 (set Pr.02-06 to 23). Upon completion of counting, the specified output terminal will be activated (Pr.02-13~02-14, Pr.02-36, 02-37 is set to 18). Pr.02-19 can't be set to 0.
- When the display shows c5555, the drive has counted 5,555 times. If display shows c5555●, it means that real counter value is between 55,550 to 55,559.

02-20 Preliminary Counting Value Attained (not return to 0)

Factory Setting: 0

Settings 0~65500

- When the counter value counts from 1 and reaches this value, the corresponding multi-function output terminal will be activated, provided one of Pr. 02-13, 02-14, 02-36, 02-37 set to 17 (Preliminary Count Value Setting). This parameter can be used for the end of the counting to make the drive runs from the low speed to stop.

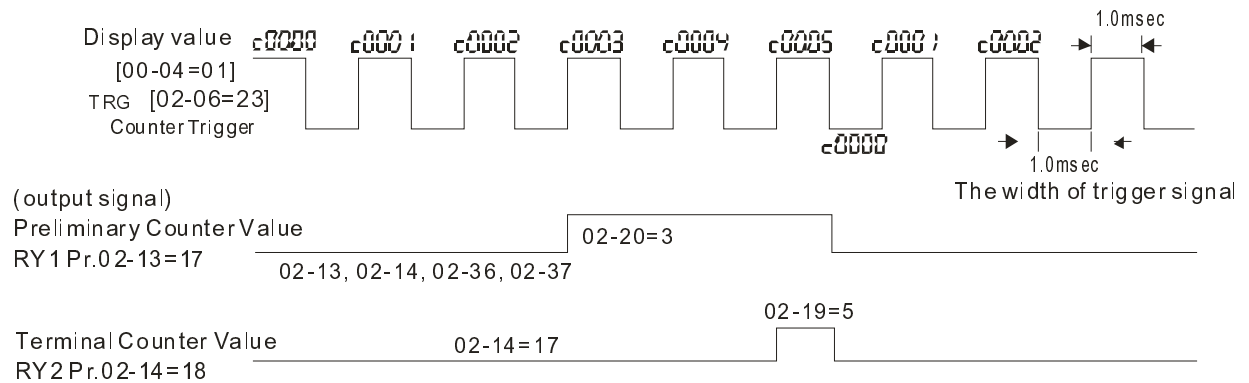

02-21 Digital Output Gain (DFM 1)

Factory Setting: 1

Settings 0~106

- It is used to set the signal for the digital output terminals (DFM-DCM) and digital frequency output (pulse X work period=50%). Output pulse per second = output frequency X Pr.02-21 ≤ 33kHz.
- When Pr02-21=0, the external terminal (DFM1) will be multi-function output. Pr02-16 sets up the function of DFM1's output.
- When Pr02-21≥1, the external terminal (DFM1) will be digital frequency output. Output frequency = H*Gain.

02-22 Desired Frequency Attained 1

Factory Setting: 60.00/50.00

Settings 0.00~600.00Hz

02-24 Desired Frequency Attained 2

Factory Setting: 60.00/50.00

Settings 0.00~600.00Hz

➤ **02-23** The Width of the Desired Frequency Attained 1

Factory Setting: 2.00

Settings 0.00~600.00Hz

➤ **02-25** The Width of the Desired Frequency Attained 2

Factory Setting: 2.00

Settings 0.00~600.00Hz

📖 Once output frequency reaches desired frequency and the corresponding multi-function output terminal is set to 3 or 4 (Pr.02-13, 02-14, 02-36, and 02-37), this multi-function output terminal will be ON.

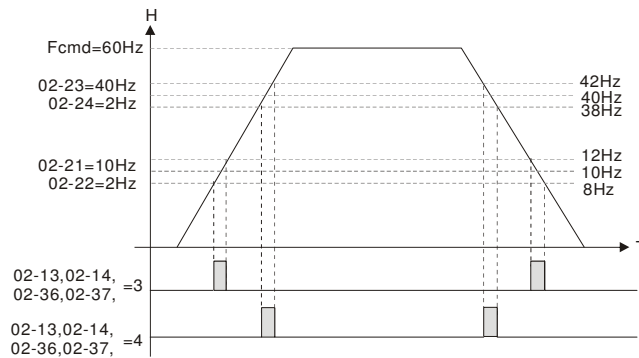

02-26 ~ Reserved

02-31

02-32 Brake Delay Time

Factory Setting: 0.000

Settings 0.000~65.000 sec

📖 When the AC motor drive runs after Pr.02-32 delay time, the corresponding multi-function output terminal (12: mechanical brake release) will be ON. It is recommended to use this function with DC brake.

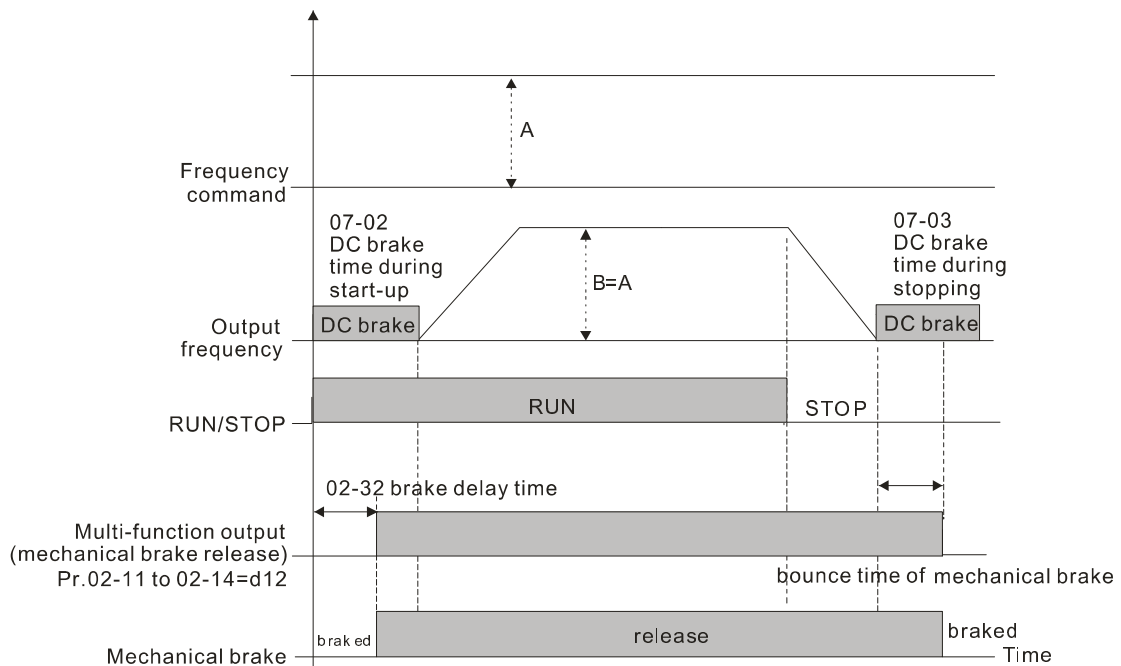

📖 If this parameter is used without DC brake, it will be invalid. Refer to the following operation timing.

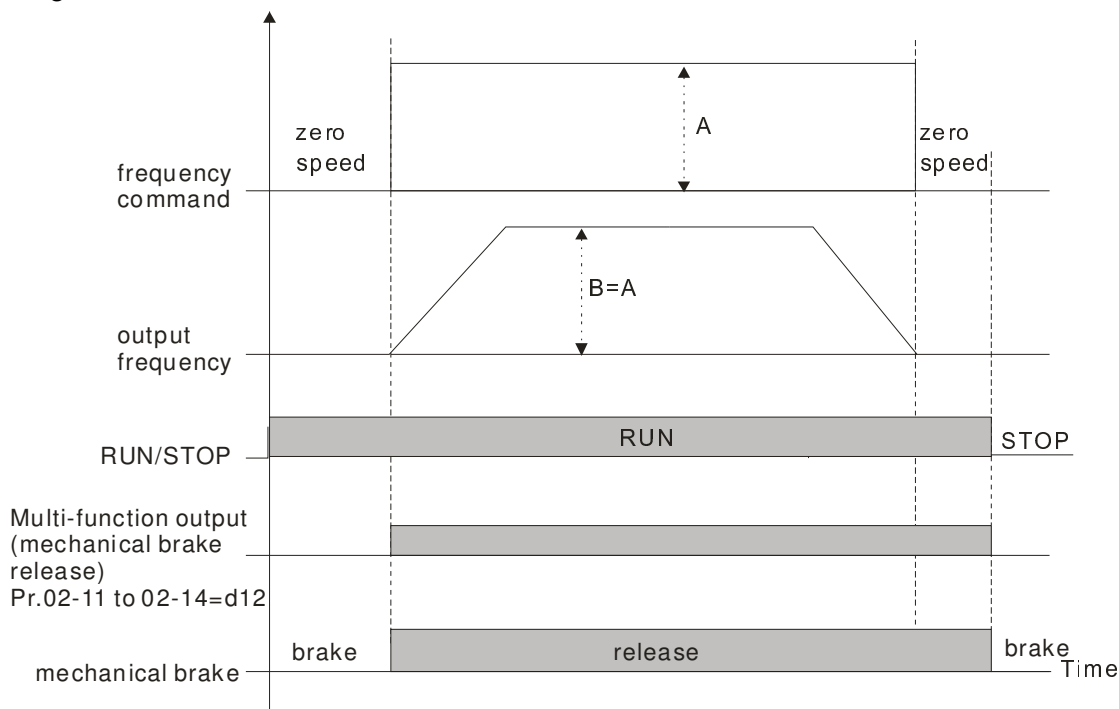

🔧 **02-33** Output Current Level Setting for Multi-function Output Terminals

Factory Setting: 0

Settings 0~100%

📖 When output current is higher or equal to Pr.02-33, it will activate multi-function output terminal (Pr.02-13, 02-14, 02-16, and 02-17 is set to 27).

📖 When output current is lower than Pr.02-33, it will activate multi-function output terminal (Pr.02-13, 02-14, 02-16, 02-17 is set to 28).

🔧 **02-34** Output Boundary for Multi-function Output Terminals

Factory Setting: 0.00

Settings 0.00~60.00Hz

📖 When output frequency is higher than Pr.02-34, it will activate the multi-function terminal (Pr.02-13, 02-14, 02-16, 02-17 is set to 29).

📖 When output frequency is lower than Pr.02-34, it will activate the multi-function terminal (Pr.02-13, 02-14, 02-16, 02-17 is set to 30).

🔧 **02-35** External Operation Control Selection after Reset and Activate

Factory Setting: 0

Settings 0: Disable

1: Drive runs if the run command still exists after reset or re-boots.

📖 Setting 1:

Status 1: After the drive is powered on and the external terminal for RUN keeps ON, the drive will run.

Status 2: After clearing fault once a fault is detected and the external terminal for RUN keeps ON, the drive can run after pressing RESET key.

02-36

~ Reserved

02-46

02-47 Zero-speed Level of Motor

Factory Setting: 0

Settings 0~65535 rpm

This parameter should be used with the multi-function output terminals (set to 43). It needs to be used with PG card and motor with encoder feedback.

This parameter is used to set the level of motor zero-speed. When the actual speed is lower than this setting, the corresponding multi-function output terminal 43 will be ON as shown as follows.

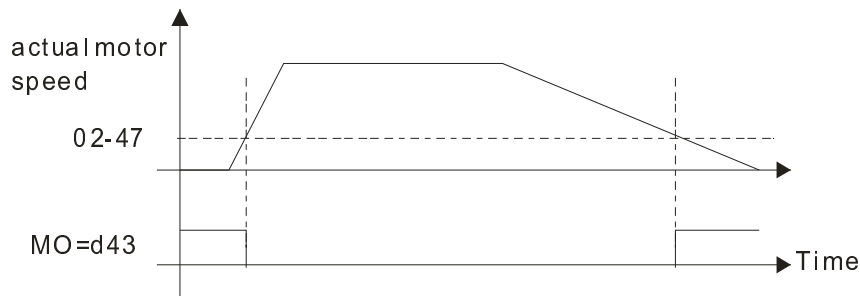

02-48 Max. Frequency of Resolution Switch

Factory Setting: 60.00

Settings 0.00~600.00Hz

02-49 Switch the delay time of Max. output frequency

Factory Setting: 0

Settings 0~65 sec.

It is used to improve the unstable speed or unstable position due to the insufficient of analog resolution. It needs to be used with external terminal (set to 43). After setting this parameter, it needs to adjust the analog output resolution of controller simultaneously by this setting.

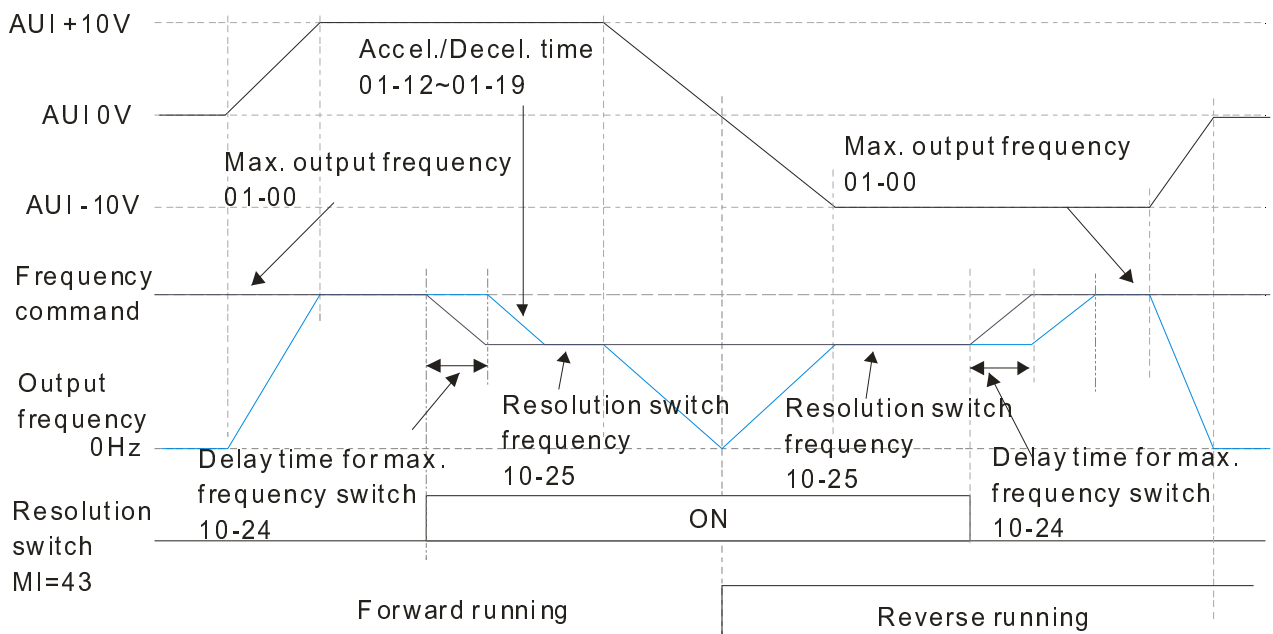

02-50 Display the Status of Multi-function Input Terminal

Factory Setting: Read only

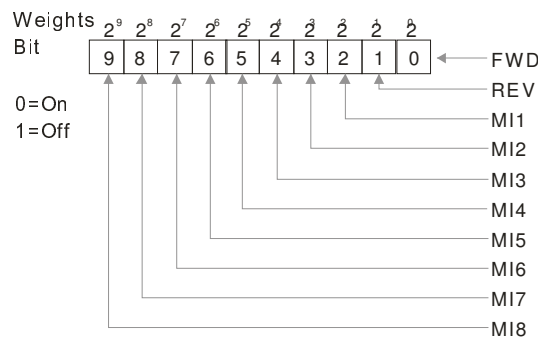

For Example:

If Pr.02-50 displays 0034h (Hex), i.e. the value is 52, and 110100 (binary). It means MI1, MI3 and MI4 are active.

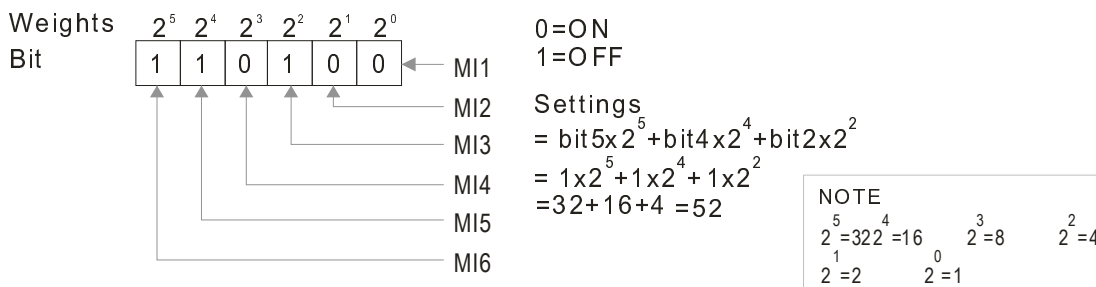

02-51 Status of Multi-function Output Terminal

Factory Setting: Read only

For Example:

If Pr.02-51 displays 000Bh (Hex), i.e. the value is 11, and 1011 (binary). It means RY1, RY2 and MO1 are ON.

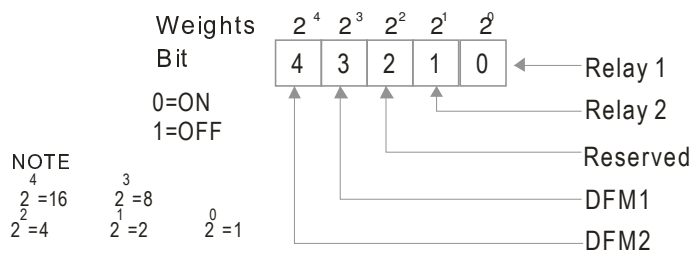

02-52 Display External Output terminal occupied by PLC

Factory Setting: Read only

P.02-52 shows the external multi-function input terminal that used by PLC.

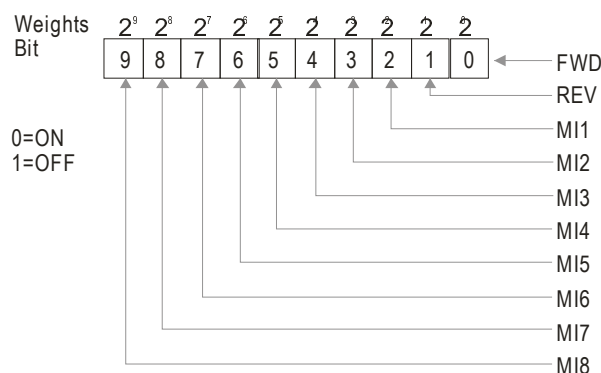

For Example:

When Pr.02-52 displays 0034h(hex) and switching to 110100 (binary), it means MI1, MI3 and MI4 are used by PLC.

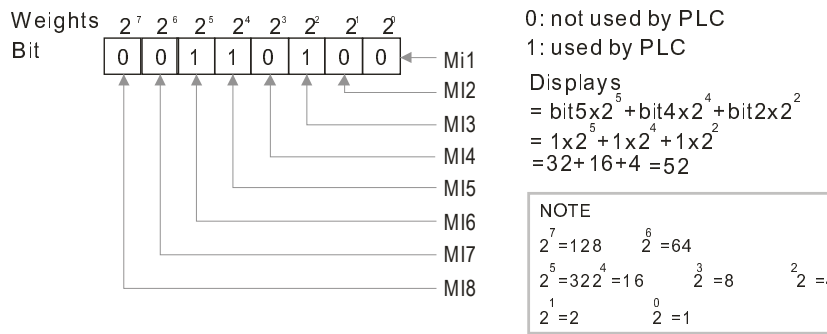

02-53 Display Analog Input Terminal occupied by PLC

Factory Setting: Read only

P.02-53 shows the external multi-function output terminal that used by PLC.

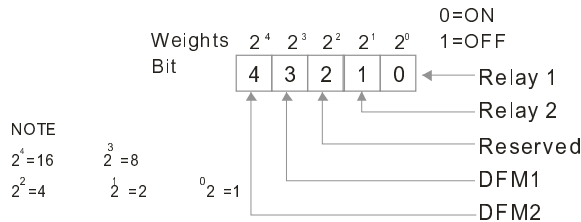

For Example:

If the value of Pr.02-53 displays 0003h (Hex), it means RY1 and RY2 are used by PLC.

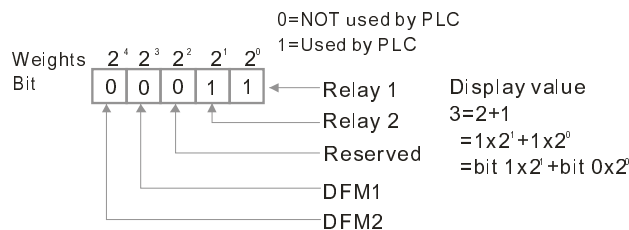

02-54 Display the Frequency Command Executed by External Terminal

Factory Setting: Read only

Settings Read only

When the source of frequency command comes from the external terminal, if Lv or Fault occurs at this time, the frequency command of the external terminal will be saved in this parameter.

02-55 Digital Output Gain (DFM 2)

Factory Setting: 1

Settings 0~106

- It is used to set the signal for the digital output terminals (DFM 2-DCM) and digital frequency output (pulse X work period=50%). Output pulse per second = output frequency X Pr.02-55 ≤ 33kHz.
- When Pr02-55=0, the external terminal (DFM2) will be multi-function output. Pr02-17 sets up the function of DFM1's output.
- When Pr02-55≥1, the external terminal (DFM2) will be digital frequency output. Output frequency = H*Gain.

03 Analog Input/Output Parameter

✎ This parameter can be set during operation.

✎ 03-00 Analog Input Selection (AVI)	Factory Setting: 1
✎ 03-01 Analog Input Selection (ACI)	Factory Setting: 0
✎ 03-02 Analog Input Selection (AUI)	Factory Setting: 0

Settings

- 0: No function
- 1: Frequency command (torque limit under torque control mode)
- 2: Torque command (torque limit under speed mode)
- 3: Torque compensation command
- 4: PID target value
- 5: PID feedback signal
- 6: PTC thermistor input value
- 7: Positive torque limit
- 8: Negative torque limit
- 9: Regenerative torque limit
- 10: Positive/negative torque limit

📖 When it is frequency command or TQC speed limit, the corresponding value for 0~±10V/4~20mA is 0 – max. output frequency(Pr.01-00)

📖 When it is torque command or torque limit, the corresponding value for 0~±10V/4~20mA is 0 – max. output torque (Pr.11-27).

📖 When it is torque compensation, the corresponding value for 0~±10V/4~20mA is 0 – rated torque.

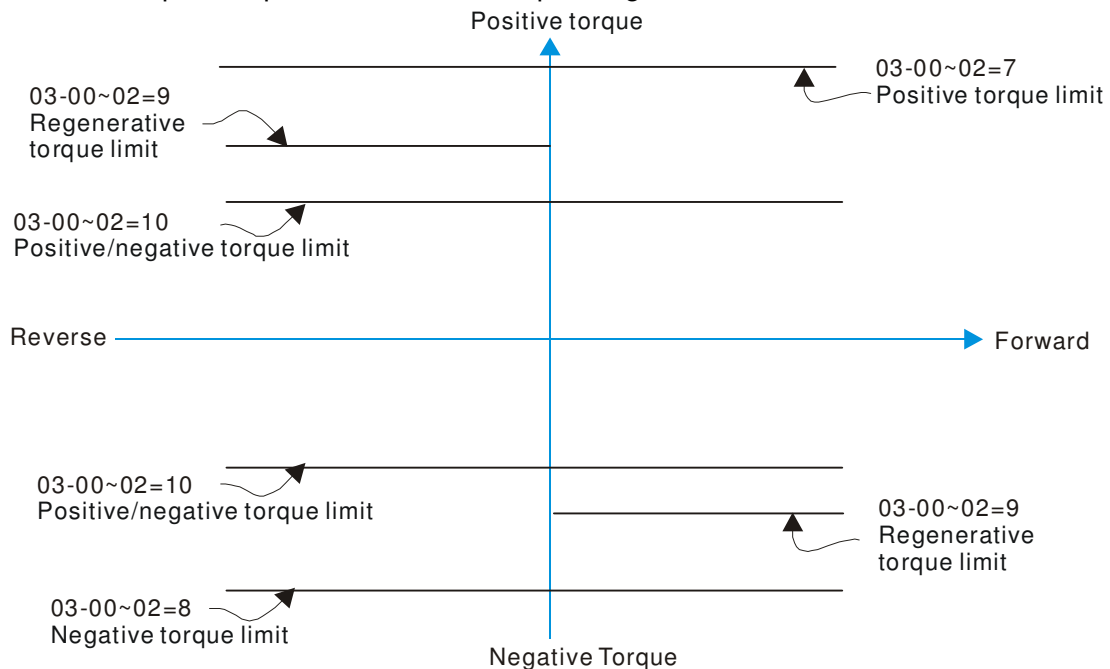

✎ 03-03 Analog Input Bias (AVI)	Factory Setting: 0
--	--------------------

Settings -100.0~100.0%

📖 It is used to set the corresponding AVI voltage of the external analog input 0.

➤ **03-04** Analog Input Bias (ACI)

Factory Setting: 0

Settings -100.0~100.0%

📖 It is used to set the corresponding ACI voltage of the external analog input 0.

➤ **03-05** Analog Voltage Input Bias (AUI)

Factory Setting: 0

Settings -100.0~100.0%

📖 It is used to set the corresponding AUI voltage of the external analog input 0.

📖 The relation between external input voltage/current and setting frequency: 0~10V (4-20mA) corresponds to 0-60Hz.

03-06 Reserved

➤ **03-07** Positive/negative Bias Mode (AVI)

➤ **03-08** Positive/negative Bias Mode (ACI)

➤ **03-09** Positive/negative Bias Mode (AUI)

Factory Setting: 0

Settings 0: Zero bias

1: Lower than or equal to bias

2: Greater than or equal to bias

3: The absolute value of the bias voltage while serving as the center

4: Serve bias as the center

📖 In a noisy environment, it is advantageous to use negative bias to provide a noise margin. It is recommended NOT to use less than 1V to set the operation frequency.

In the diagram below: Black color line: Frequency. Gray color line: Voltage

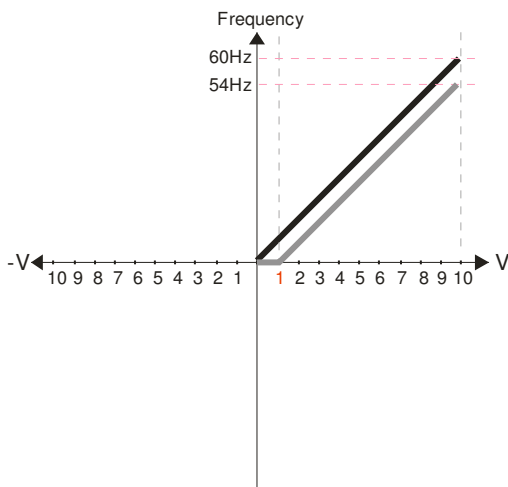

Pr.03-03=10%

Pr.03-07~03-09 (Positive/Negative Bias Mode)

0: No bias

1: Lower than or equal to bias

2: Greater than or equal to bias

3: The absolute value of the bias voltage

while serving as the center

4: Serve bias as the center

Pr.03-10 (Analog Frequency Command for Reverse Run)

0: Negative frequency is not valid.

Forward and reverse run is controlled by digital keypad or external terminal.

1: Neagive frequency is valid. Positive frequency = forward run; negative frequency = reverse run. Direction can not be switched by digital keypad or external terminal control.

Pr.03-11 Analog Input Gain (AVI)= 100%

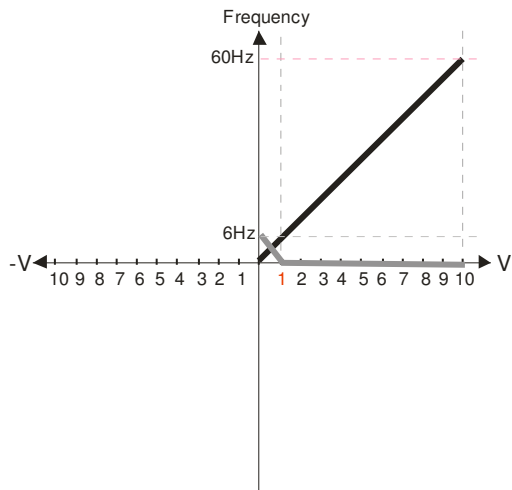

Pr.03-03=10%

Pr.03-07~03-09 (Positive/Negative Bias Mode)

- 0: No bias
- 1: Lower than or equal to bias
- 2: Greater than or equal to bias
- 3: The absolute value of the bias voltage while serving as the center
- 4: Serve bias as the center

Pr.03-10 (Analog Frequency Command for Reverse Run)

- 0: Negative frequency is not valid. Forward and reverse run is controlled by digital keypad or external terminal.
- 1: Negative frequency is valid. Positive frequency = forward run; negative frequency = reverse run. Direction can not be switched by digital keypad or external terminal control.

Pr.03-11 Analog Input Gain (AVI)=100%

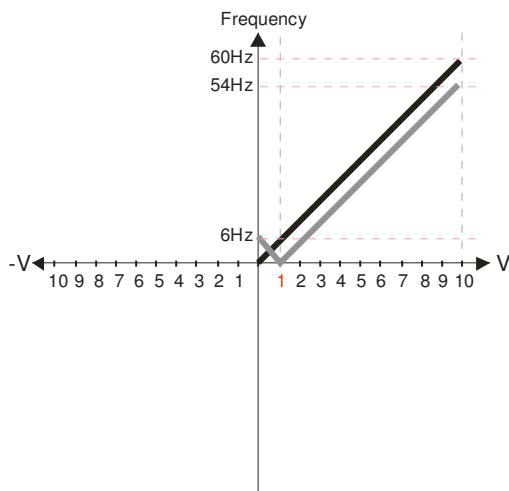

Pr.03-03=10%

Pr.03-07~03-09 (Positive/Negative Bias Mode)

- 0: No bias
- 1: Lower than or equal to bias
- 2: Greater than or equal to bias
- 3: The absolute value of the bias voltage while serving as the center
- 4: Serve bias as the center

Pr.03-10 (Analog Frequency Command for Reverse Run)

- 0: Negative frequency is not valid. Forward and reverse run is controlled by digital keypad or external terminal.
- 1: Negative frequency is valid. Positive frequency = forward run; negative frequency = reverse run. Direction can not be switched by digital keypad or external terminal control.

Pr.03-11 Analog Input Gain (AVI) = 100%

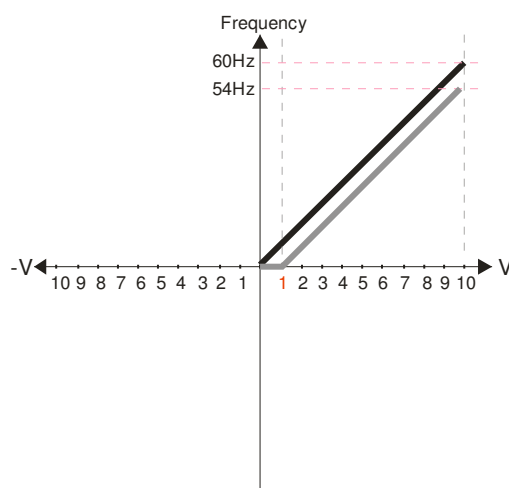

Pr.03-03=10%

Pr.03-07~03-09 (Positive/Negative Bias Mode)

- 0: No bias
- 1: Lower than or equal to bias
- 2: Greater than or equal to bias
- 3: The absolute value of the bias voltage while serving as the center
- 4: Serve bias as the center

Pr.03-10 (Analog Frequency Command for Reverse Run)

- 0: Negative frequency is not valid. Forward and reverse run is controlled by digital keypad or external terminal.
- 1: Negative frequency is valid. Positive frequency = forward run; negative frequency = reverse run. Direction can not be switched by digital keypad or external terminal control.

Pr.03-11 Analog Input Gain (AVI) = 100%

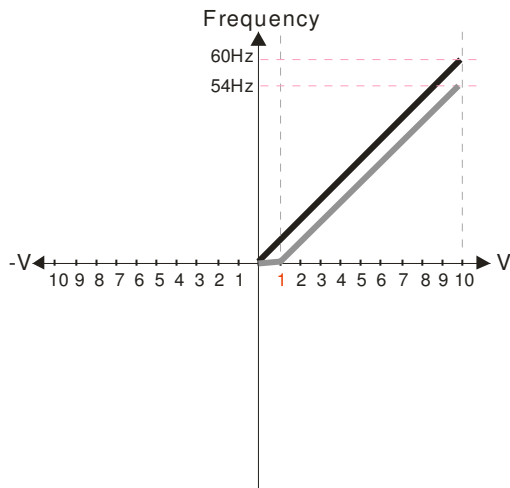

Pr.03-03=10%

Pr.03-07~03-09 (Positive/Negative Bias Mode)

- 0: No bias
- 1: Lower than or equal to bias
- 2: Greater than or equal to bias
- 3: The absolute value of the bias voltage while serving as the center
- 4: Serve bias as the center

Pr.03-10 (Analog Frequency Command for Reverse Run)

- 0: Negative frequency is not valid. Forward and reverse run is controlled by digital keypad or external terminal.
- 1: Negative frequency is valid. Positive frequency = forward run; negative frequency = reverse run. Direction can not be switched by digital keypad or external terminal control.

Pr.03-11 Analog Input Gain (AVI)= 100%

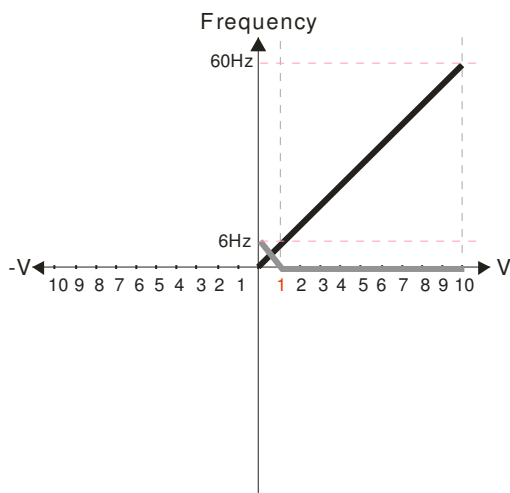

Pr.03-03=10%

Pr.03-07~03-09 (Positive/Negative Bias Mode)

- 0: No bias
- 1: Lower than or equal to bias
- 2: Greater than or equal to bias
- 3: The absolute value of the bias voltage while serving as the center
- 4: Serve bias as the center

Pr.03-10 (Analog Frequency Command for Reverse Run)

- 0: Negative frequency is not valid. Forward and reverse run is controlled by digital keypad or external terminal.
- 1: Negative frequency is valid. Positive frequency = forward run; negative frequency = reverse run. Direction can not be switched by digital keypad or external terminal control.

Pr.03-11 Analog Input Gain (AVI)= 100%

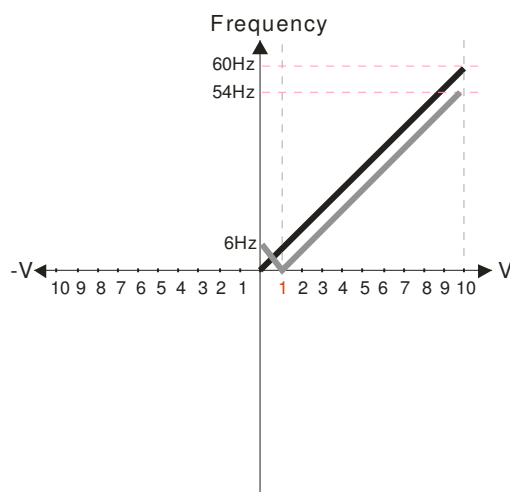

Pr.03-03=10%

Pr.03-07~03-09 (Positive/Negative Bias Mode)

- 0: No bias
- 1: Lower than or equal to bias
- 2: Greater than or equal to bias
- 3: The absolute value of the bias voltage while serving as the center
- 4: Serve bias as the center

Pr.03-10 (Analog Frequency Command for Reverse Run)

- 0: Negative frequency is not valid. Forward and reverse run is controlled by digital keypad or external terminal.
- 1: Negative frequency is valid. Positive frequency = forward run; negative frequency = reverse run. Direction can not be switched by digital keypad or external terminal control.

Pr.03-11 Analog Input Gain (AVI) = 100%

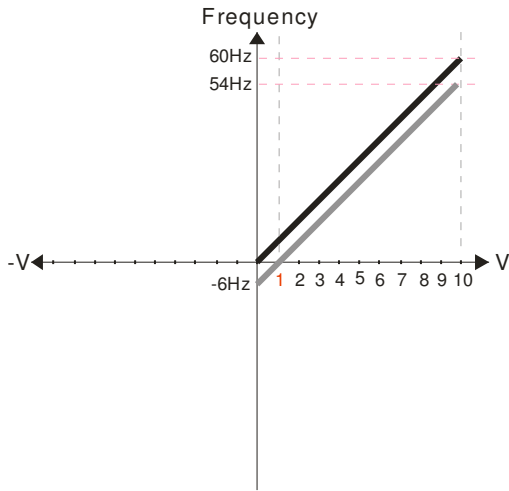

Pr.03-03=10%

Pr.03-07~03-09 (Positive/Negative Bias Mode)

- 0: No bias
- 1: Lower than or equal to bias
- 2: Greater than or equal to bias
- 3: The absolute value of the bias voltage while serving as the center
- 4: Serve bias as the center

Pr.03-10 (Analog Frequency Command for Reverse Run)

- 0: Negative frequency is not valid. Forward and reverse run is controlled by digital keypad or external terminal.
- 1: Negative frequency is valid. Positive frequency = forward run; negative frequency = reverse run. Direction can not be switched by digital keypad or external terminal control.

Pr.03-11 Analog Input Gain (AVI) = 100%

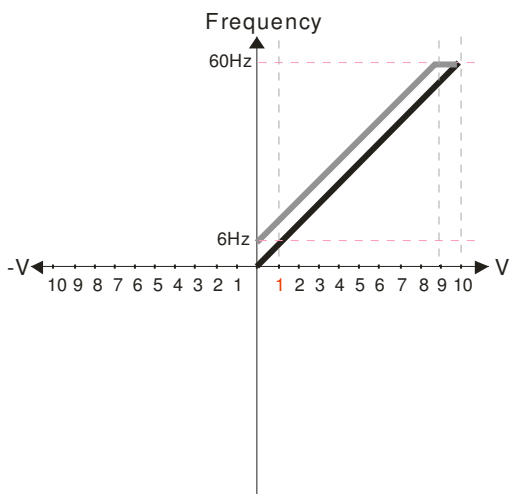

Pr.03-03=-10%

Pr.03-07~03-09 (Positive/Negative Bias Mode)

- 0: No bias
- 1: Lower than or equal to bias
- 2: Greater than or equal to bias
- 3: The absolute value of the bias voltage while serving as the center
- 4: Serve bias as the center

Pr.03-10 (Analog Frequency Command for Reverse Run)

- 0: Negative frequency is not valid. Forward and reverse run is controlled by digital keypad or external terminal.
- 1: Negative frequency is valid. Positive frequency = forward run; negative frequency = reverse run. Direction can not be switched by digital keypad or external terminal control.

Pr.03-11 Analog Input Gain (AVI)= 100%

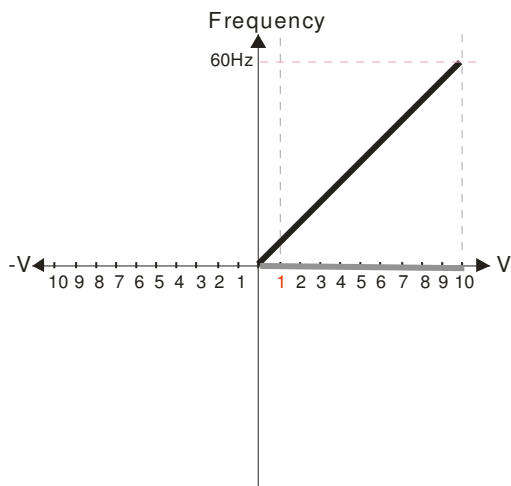

Pr.03-03=-10%

Pr.03-07~03-09 (Positive/Negative Bias Mode)

- 0: No bias
- 1: Lower than or equal to bias
- 2: Greater than or equal to bias
- 3: The absolute value of the bias voltage while serving as the center
- 4: Serve bias as the center

Pr.03-10 (Analog Frequency Command for Reverse Run)

- 0: Negative frequency is not valid. Forward and reverse run is controlled by digital keypad or external terminal.
- 1: Negative frequency is valid. Positive frequency = forward run; negative frequency = reverse run. Direction can not be switched by digital keypad or external terminal control.

Pr.03-11 Analog Input Gain (AVI)= 100%

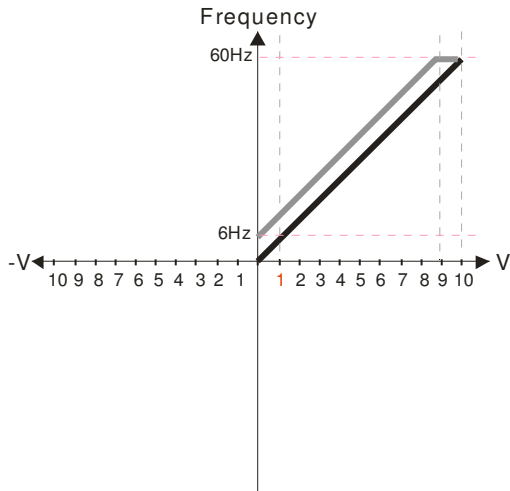

Pr.03-03=-10%

Pr.03-07~03-09 (Positive/Negative Bias Mode)

- 0: No bias
- 1: Lower than or equal to bias
- 2: Greater than or equal to bias
- 3: The absolute value of the bias voltage while serving as the center
- 4: Serve bias as the center

Pr.03-10 (Analog Frequency Command for Reverse Run)

- 0: Negative frequency is not valid. Forward and reverse run is controlled by digital keypad or external terminal.
- 1: Negative frequency is valid. Positive frequency = forward run; negative frequency = reverse run. Direction can not be switched by digital keypad or external terminal control.

Pr.03-11 Analog Input Gain (AVI) = 100%

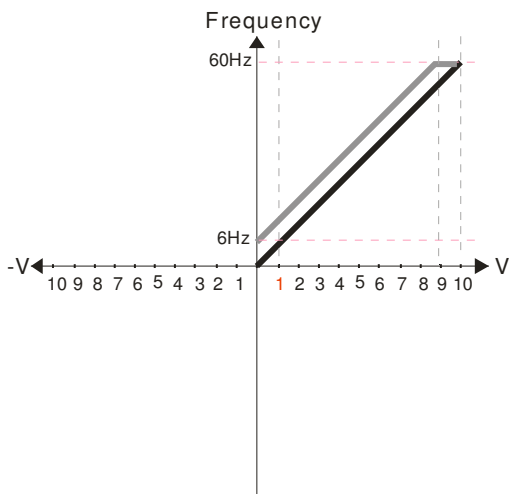

Pr.03-03=-10%

Pr.03-07~03-09 (Positive/Negative Bias Mode)

- 0: No bias
- 1: Lower than or equal to bias
- 2: Greater than or equal to bias
- 3: The absolute value of the bias voltage while serving as the center
- 4: Serve bias as the center

Pr.03-10 (Analog Frequency Command for Reverse Run)

- 0: Negative frequency is not valid. Forward and reverse run is controlled by digital keypad or external terminal.
- 1: Negative frequency is valid. Positive frequency = forward run; negative frequency = reverse run. Direction can not be switched by digital keypad or external terminal control.

Pr.03-11 Analog Input Gain (AVI) = 100%

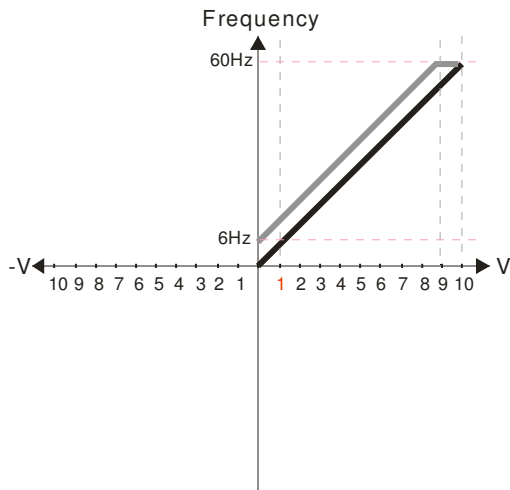

Pr.03-03=-10%

Pr.03-07~03-09 (Positive/Negative Bias Mode)

- 0: No bias
- 1: Lower than or equal to bias
- 2: Greater than or equal to bias
- 3: The absolute value of the bias voltage while serving as the center
- 4: Serve bias as the center

Pr.03-10 (Analog Frequency Command for Reverse Run)

- 0: Negative frequency is not valid. Forward and reverse run is controlled by digital keypad or external terminal.
- 1: Negative frequency is valid. Positive frequency = forward run; negative frequency = reverse run. Direction can not be switched by digital keypad or external terminal control.

Pr.03-11 Analog Input Gain (AVI)= 100%

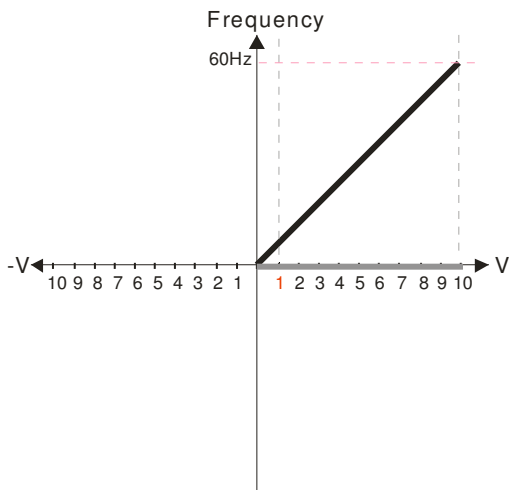

Pr.03-03=-10%

Pr.03-07~03-09 (Positive/Negative Bias Mode)

- 0: No bias
- 1: Lower than or equal to bias
- 2: Greater than or equal to bias
- 3: The absolute value of the bias voltage while serving as the center
- 4: Serve bias as the center

Pr.03-10 (Analog Frequency Command for Reverse Run)

- 0: Negative frequency is not valid. Forward and reverse run is controlled by digital keypad or external terminal.
- 1: Negative frequency is valid. Positive frequency = forward run; negative frequency = reverse run. Direction can not be switched by digital keypad or external terminal control.

Pr.03-11 Analog Input Gain (AVI)= 100%

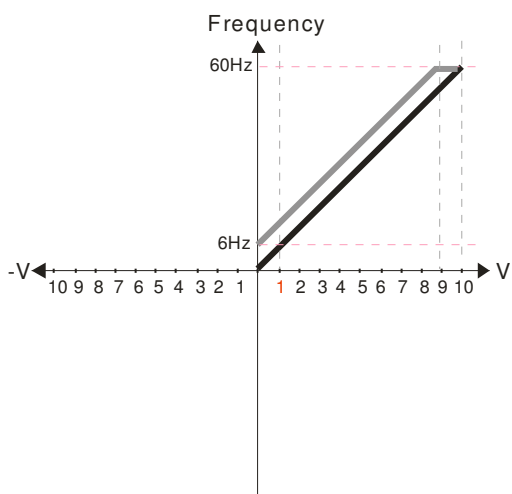

Pr.03-03=-10%

Pr.03-07~03-09 (Positive/Negative Bias Mode)

- 0: No bias
- 1: Lower than or equal to bias
- 2: Greater than or equal to bias
- 3: The absolute value of the bias voltage while serving as the center
- 4: Serve bias as the center

Pr.03-10 (Analog Frequency Command for Reverse Run)

- 0: Negative frequency is not valid. Forward and reverse run is controlled by digital keypad or external terminal.
- 1: Negative frequency is valid. Positive frequency = forward run; negative frequency = reverse run. Direction can not be switched by digital keypad or external terminal control.

Pr.03-11 Analog Input Gain (AVI) = 100%

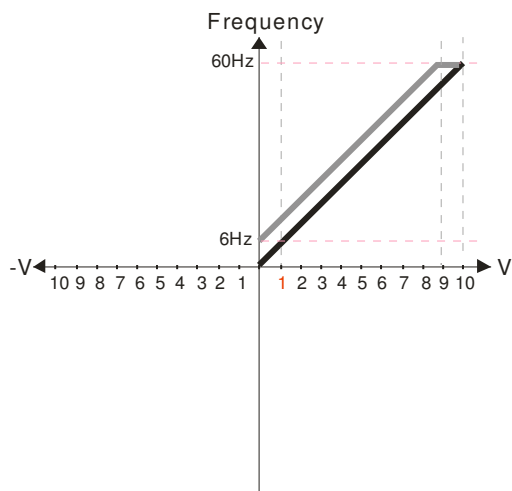

Pr.03-03=-10%

Pr.03-07~03-09 (Positive/Negative Bias Mode)

- 0: No bias
- 1: Lower than or equal to bias
- 2: Greater than or equal to bias
- 3: The absolute value of the bias voltage while serving as the center
- 4: Serve bias as the center

Pr.03-10 (Analog Frequency Command for Reverse Run)

- 0: Negative frequency is not valid. Forward and reverse run is controlled by digital keypad or external terminal.
- 1: Negative frequency is valid. Positive frequency = forward run; negative frequency = reverse run. Direction can not be switched by digital keypad or external terminal control.

Pr.03-11 Analog Input Gain (AVI) = 100%

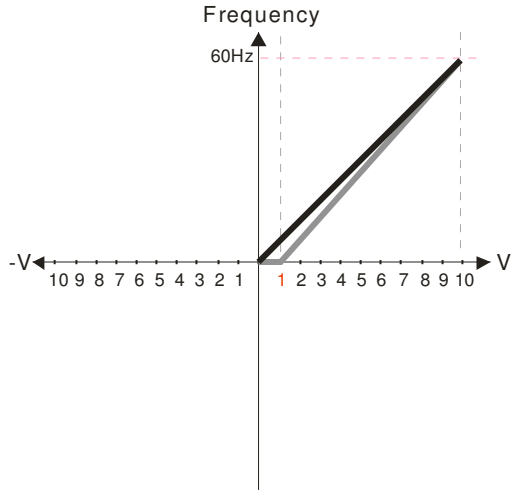

Pr.03-03=-10%

Pr.03-07~03-09 (Positive/Negative Bias Mode)

- 0: No bias
- 1: Lower than or equal to bias
- 2: Greater than or equal to bias
- 3: The absolute value of the bias voltage while serving as the center
- 4: Serve bias as the center

Pr.03-10 (Analog Frequency Command for Reverse Run)

- 0: Negative frequency is not valid. Forward and reverse run is controlled by digital keypad or external terminal.
- 1: Negative frequency is valid. Positive frequency = forward run; negative frequency = reverse run. Direction can not be switched by digital keypad or external terminal control.

Pr.03-11 Analog Input Gain (AVI)= 111.1%
10/9=111.1%

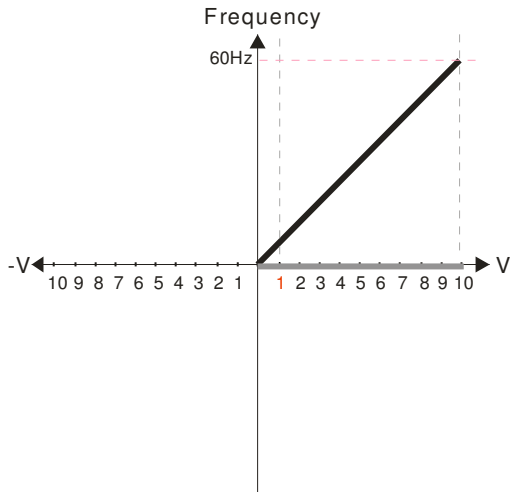

Pr.03-03=10%

Pr.03-07~03-09 (Positive/Negative Bias Mode)

- 0: No bias
- 1: Lower than or equal to bias
- 2: Greater than or equal to bias
- 3: The absolute value of the bias voltage while serving as the center
- 4: Serve bias as the center

Pr.03-10 (Analog Frequency Command for Reverse Run)

- 0: Negative frequency is not valid. Forward and reverse run is controlled by digital keypad or external terminal.
- 1: Negative frequency is valid. Positive frequency = forward run; negative frequency = reverse run. Direction can not be switched by digital keypad or external terminal control.

Pr.03-11 Analog Input Gain (AVI)=111.1%
10/9 = 111.1%

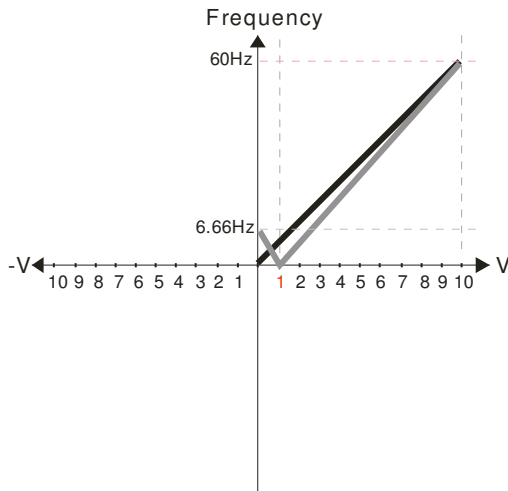

Pr.03-03=10%

Pr.03-07~03-09 (Positive/Negative Bias Mode)

- 0: No bias
- 1: Lower than or equal to bias
- 2: Greater than or equal to bias
- 3: The absolute value of the bias voltage while serving as the center
- 4: Serve bias as the center

Pr.03-10 (Analog Frequency Command for Reverse Run)

- 0: Negative frequency is not valid. Forward and reverse run is controlled by digital keypad or external terminal.
- 1: Negative frequency is valid. Positive frequency = forward run; negative frequency = reverse run. Direction can not be switched by digital keypad or external terminal control.

Pr.03-11 Analog Input Gain (AVI) = 111.1%
10/9 = 111.1%

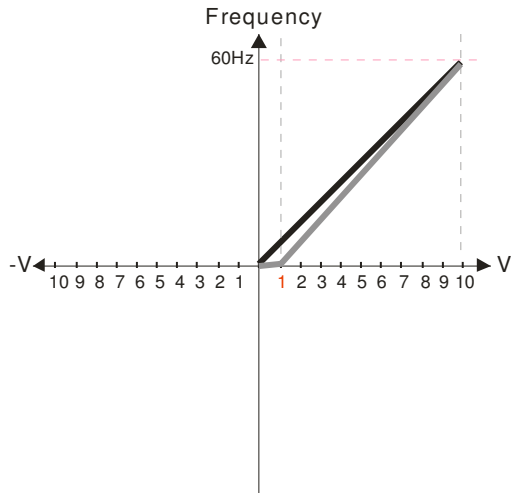

Pr.03-03=10%

Pr.03-07~03-09 (Positive/Negative Bias Mode)

- 0: No bias
- 1: Lower than or equal to bias
- 2: Greater than or equal to bias
- 3: The absolute value of the bias voltage while serving as the center
- 4: Serve bias as the center

Pr.03-10 (Analog Frequency Command for Reverse Run)

- 0: Negative frequency is not valid. Forward and reverse run is controlled by digital keypad or external terminal.
- 1: Negative frequency is valid. Positive frequency = forward run; negative frequency = reverse run. Direction can not be switched by digital keypad or external terminal control.

Pr.03-11 Analog Input Gain (AVI) = 111.1%
 $10/9 = 111.1\%$

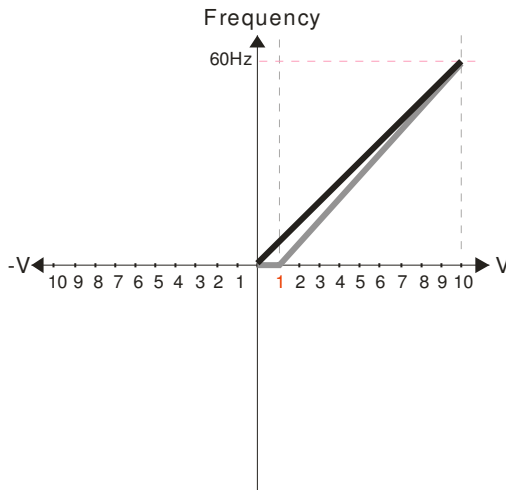

Pr.03-03=10%

Pr.03-07~03-09 (Positive/Negative Bias Mode)

- 0: No bias
- 1: Lower than or equal to bias
- 2: Greater than or equal to bias
- 3: The absolute value of the bias voltage while serving as the center
- 4: Serve bias as the center

Pr.03-10 (Analog Frequency Command for Reverse Run)

- 0: Negative frequency is not valid. Forward and reverse run is controlled by digital keypad or external terminal.
- 1: Negative frequency is valid. Positive frequency = forward run; negative frequency = reverse run. Direction can not be switched by digital keypad or external terminal control.

Pr.03-11 Analog Input Gain (AVI) = 111.1%
 $10/9 = 111.1\%$

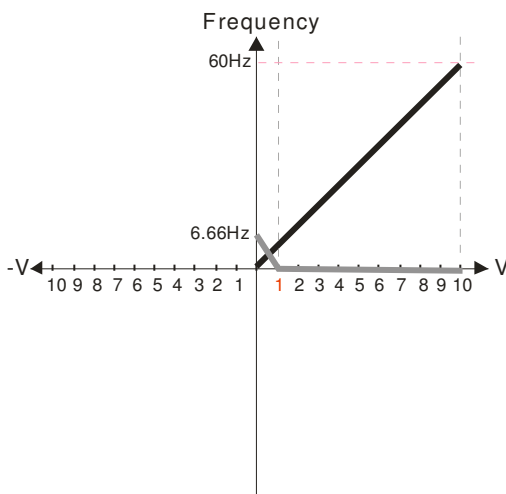

Pr.03-03=10%

Pr.03-07~03-09 (Positive/Negative Bias Mode)

- 0: No bias
- 1: Lower than or equal to bias
- 2: Greater than or equal to bias
- 3: The absolute value of the bias voltage while serving as the center
- 4: Serve bias as the center

Pr.03-10 (Analog Frequency Command for Reverse Run)

- 0: Negative frequency is not valid. Forward and reverse run is controlled by digital keypad or external terminal.
- 1: Negative frequency is valid. Positive frequency = forward run; negative frequency = reverse run. Direction can not be switched by digital keypad or external terminal control.

Pr.03-11 Analog Input Gain (AVI) = 111.1%
 $10/9 = 111.1\%$

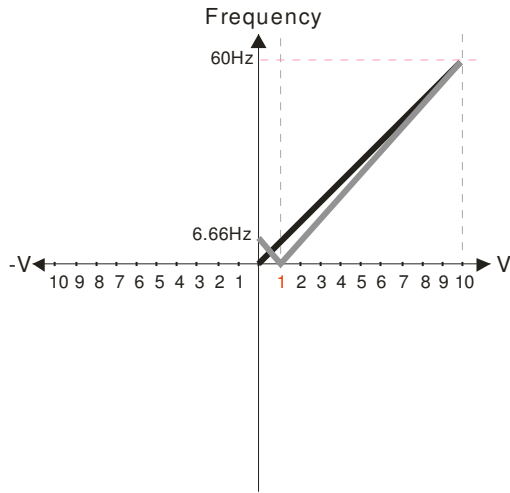

Pr.03-03=10%

Pr.03-07~03-09 (Positive/Negative Bias Mode)

- 0: No bias
- 1: Lower than or equal to bias
- 2: Greater than or equal to bias
- 3: The absolute value of the bias voltage while serving as the center
- 4: Serve bias as the center

Pr.03-10 (Analog Frequency Command for Reverse Run)

- 0: Negative frequency is not valid. Forward and reverse run is controlled by digital keypad or external terminal.
- 1: Negative frequency is valid. Positive frequency = forward run; negative frequency = reverse run. Direction can not be switched by digital keypad or external terminal control.

Pr03-11 Analog Input Gain (AVI) = 111.1%
 $10/9 = 111.1\%$

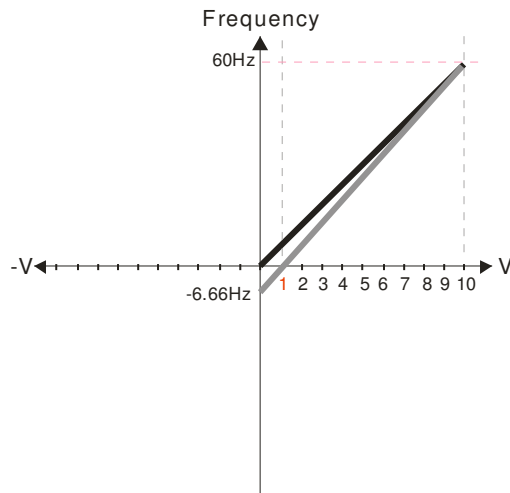

Pr.03-03=10%

Pr.03-07~03-09 (Positive/Negative Bias Mode)

- 0: No bias
- 1: Lower than or equal to bias
- 2: Greater than or equal to bias
- 3: The absolute value of the bias voltage while serving as the center
- 4: Serve bias as the center

Pr.03-10 (Analog Frequency Command for Reverse Run)

- 0: Negative frequency is not valid. Forward and reverse run is controlled by digital keypad or external terminal.
- 1: Negative frequency is valid. Positive frequency = forward run; negative frequency = reverse run. Direction can not be switched by digital keypad or external terminal control.

Pr03-11 Analog Input Gain (AVI) = 100%
 $10/9 = 111.1\%$

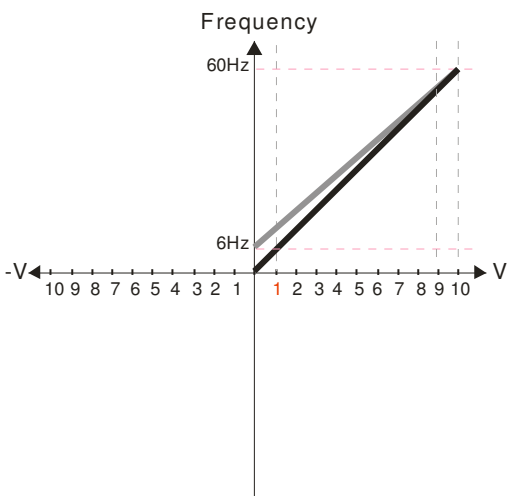

Pr.03-07~03-09 (Positive/Negative Bias Mode)

- 0: No bias
- 1: Lower than or equal to bias
- 2: Greater than or equal to bias
- 3: The absolute value of the bias voltage while serving as the center
- 4: Serve bias as the center

Pr.03-10 (Analog Frequency Command for Reverse Run)

- 0: Negative frequency is not valid. Forward and reverse run is controlled by digital keypad or external terminal.
- 1: Negative frequency is valid. Positive frequency = forward run; negative frequency = reverse run. Direction can not be switched by digital keypad or external terminal control.

Calculate the bias: $\frac{60-6\text{Hz}}{10\text{V}} = \frac{6-0\text{Hz}}{\text{XV}}$ $\text{XV} = \frac{10}{9} = 1.11\text{V}$

$\therefore \text{Pr.03-03} = \frac{1.11}{10} \times 100\%$

Calculate the gain: $\text{Pr.03-11} = \frac{10\text{V}}{11.1\text{V}} \times 100\% = 90.0\%$

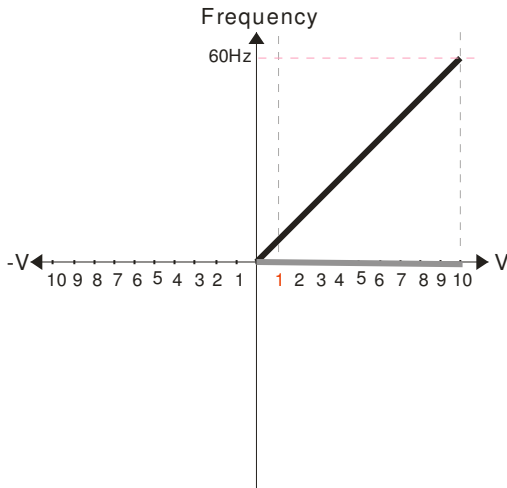

Pr.03-07~03-09 (Positive/Negative Bias Mode)

- 0: No bias
- 1: Lower than or equal to bias
- 2: Greater than or equal to bias
- 3: The absolute value of the bias voltage while serving as the center
- 4: Serve bias as the center

Pr.03-10 (Analog Frequency Command for Reverse Run)

- 0: Negative frequency is not valid. Forward and reverse run is controlled by digital keypad or external terminal.
- 1: Negative frequency is valid. Positive frequency = forward run; negative frequency = reverse run. Direction can not be switched by digital keypad or external terminal control.

Calculate the bias: $\frac{60-6\text{Hz}}{10\text{V}} = \frac{6-0\text{Hz}}{\text{XV}}$ $\text{XV} = \frac{10}{9} = 1.11\text{V}$

$\therefore \text{Pr.03-03} = \frac{1.11}{10} \times 100\%$

Calculate the gain: $\text{Pr.03-11} = \frac{10\text{V}}{11.1\text{V}} \times 100\% = 90.0\%$

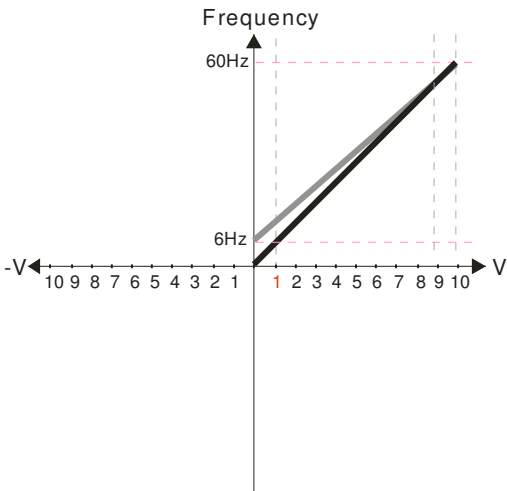

Pr.03-07~03-09 (Positive/Negative Bias Mode)

- 0: No bias
- 1: Lower than or equal to bias
- 2: Greater than or equal to bias
- 3: The absolute value of the bias voltage while serving as the center
- 4: Serve bias as the center

Pr.03-10 (Analog Frequency Command for Reverse Run)

- 0: Negative frequency is not valid. Forward and reverse run is controlled by digital keypad or external terminal.
- 1: Negative frequency is valid. Positive frequency = forward run; negative frequency = reverse run. Direction can not be switched by digital keypad or external terminal control.

Calculate the bias: $\frac{60-6\text{Hz}}{10\text{V}} = \frac{6-0\text{Hz}}{\text{XV}}$ $\text{XV} = \frac{10}{9} = 1.11\text{V}$

$\therefore \text{Pr.03-03} = \frac{1.11}{10} \times 100\%$

Calculate the gain: $\text{Pr.03-11} = \frac{10\text{V}}{11.1\text{V}} \times 100\% = 90.0\%$

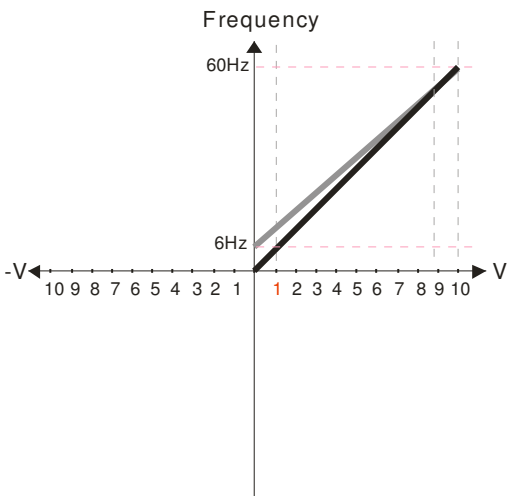

Pr.03-07~03-09 (Positive/Negative Bias Mode)

- 0: No bias
- 1: Lower than or equal to bias
- 2: Greater than or equal to bias
- 3: The absolute value of the bias voltage while serving as the center
- 4: Serve bias as the center

Pr.03-10 (Analog Frequency Command for Reverse Run)

- 0: Negative frequency is not valid. Forward and reverse run is controlled by digital keypad or external terminal.
- 1: Negative frequency is valid. Positive frequency = forward run; negative frequency = reverse run. Direction can not be switched by digital keypad or external terminal control.

Calculate the bias: $\frac{60-6\text{Hz}}{10\text{V}} = \frac{6-0\text{Hz}}{\text{XV}}$ $\text{XV} = \frac{10}{9} = 1.11\text{V}$

$\therefore \text{Pr.03-03} = \frac{1.11}{10} \times 100\%$

Calculate the gain: $\text{Pr.03-11} = \frac{10\text{V}}{11.1\text{V}} \times 100\% = 90.0\%$

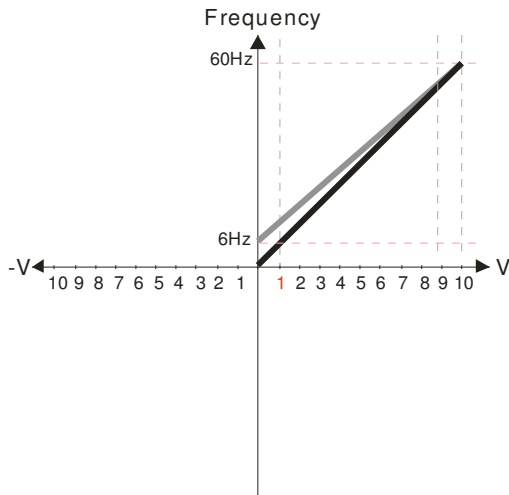

Pr.03-07~03-09 (Positive/Negative Bias Mode)

- 0: No bias
- 1: Lower than or equal to bias
- 2: Greater than or equal to bias
- 3: The absolute value of the bias voltage while serving as the center
- 4: Serve bias as the center

Pr.03-10 (Analog Frequency Command for Reverse Run)

- 0: Negative frequency is not valid. Forward and reverse run is controlled by digital keypad or external terminal.
- 1: Negative frequency is valid. Positive frequency = forward run; negative frequency = reverse run. Direction can not be switched by digital keypad or external terminal control.

Calculate the bias: $\frac{60-6\text{Hz}}{10\text{V}} = \frac{6-0\text{Hz}}{X\text{V}} \Rightarrow X\text{V} = \frac{10}{9} = 1.11\text{V}$
 $\therefore \text{Pr.03-03} = \frac{1.11}{10} \times 100\%$

Calculate the gain: $\text{Pr.03-11} = \frac{10\text{V}}{11.1\text{V}} \times 100\% = 90.0\%$

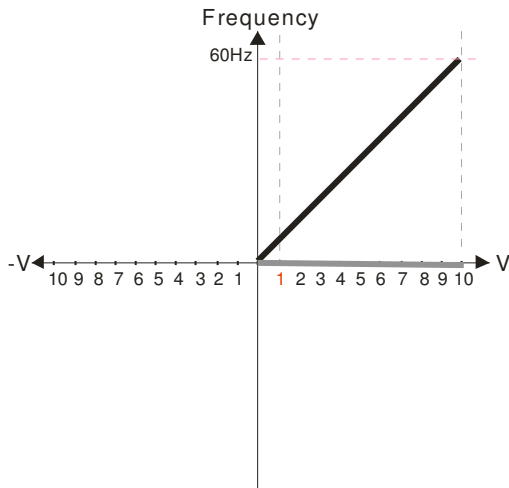

Pr.03-07~03-09 (Positive/Negative Bias Mode)

- 0: No bias
- 1: Lower than or equal to bias
- 2: Greater than or equal to bias
- 3: The absolute value of the bias voltage while serving as the center
- 4: Serve bias as the center

Pr.03-10 (Analog Frequency Command for Reverse Run)

- 0: Negative frequency is not valid. Forward and reverse run is controlled by digital keypad or external terminal.
- 1: Negative frequency is valid. Positive frequency = forward run; negative frequency = reverse run. Direction can not be switched by digital keypad or external terminal control.

Calculate the bias: $\frac{60-6\text{Hz}}{10\text{V}} = \frac{6-0\text{Hz}}{X\text{V}} \Rightarrow X\text{V} = \frac{10}{9} = 1.11\text{V}$
 $\therefore \text{Pr.03-03} = \frac{1.11}{10} \times 100\%$

Calculate the gain: $\text{Pr.03-11} = \frac{10\text{V}}{11.1\text{V}} \times 100\% = 90.0\%$

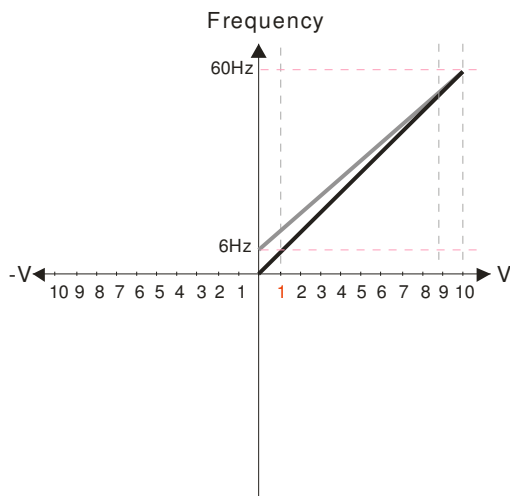

Pr.03-07~03-09 (Positive/Negative Bias Mode)

- 0: No bias
- 1: Lower than or equal to bias
- 2: Greater than or equal to bias
- 3: The absolute value of the bias voltage while serving as the center
- 4: Serve bias as the center

Pr.03-10 (Analog Frequency Command for Reverse Run)

- 0: Negative frequency is not valid. Forward and reverse run is controlled by digital keypad or external terminal.
- 1: Negative frequency is valid. Positive frequency = forward run; negative frequency = reverse run. Direction can not be switched by digital keypad or external terminal control.

Calculate the bias: $\frac{60-6\text{Hz}}{10\text{V}} = \frac{6-0\text{Hz}}{X\text{V}} \Rightarrow X\text{V} = \frac{10}{9} = 1.11\text{V}$
 $\therefore \text{Pr.03-03} = \frac{1.11}{10} \times 100\%$

Calculate the gain: $\text{Pr.03-11} = \frac{10\text{V}}{11.1\text{V}} \times 100\% = 90.0\%$

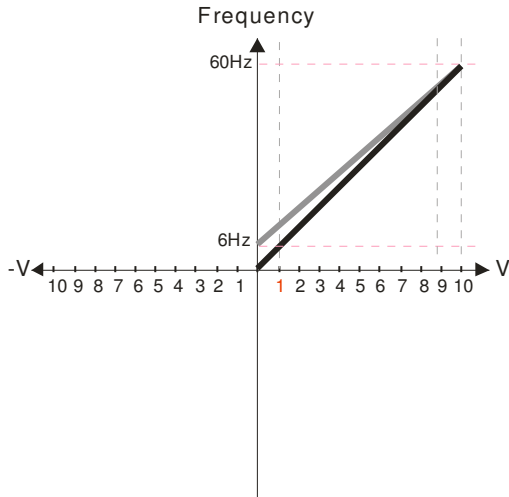

Pr.03-07~03-09 (Positive/Negative Bias Mode)

- 0: No bias
- 1: Lower than or equal to bias
- 2: Greater than or equal to bias
- 3: The absolute value of the bias voltage while serving as the center
- 4: Serve bias as the center

Pr.03-10 (Analog Frequency Command for Reverse Run)

- 0: Negative frequency is not valid. Forward and reverse run is controlled by digital keypad or external terminal.
- 1: Negative frequency is valid. Positive frequency = forward run; negative frequency = reverse run. Direction can not be switched by digital keypad or external terminal control.

Calculate the bias: $\frac{60-6\text{Hz}}{10\text{V}} = \frac{6-0\text{Hz}}{\text{XV}} \Rightarrow \text{XV} = \frac{10}{9} = 1.11\text{V}$

$\therefore \text{Pr.03-03} = \frac{1.11}{10} \times 100\%$

Calculate the gain: $\text{Pr.03-11} = \frac{10\text{V}}{11.1\text{V}} \times 100\% = 90.0\%$

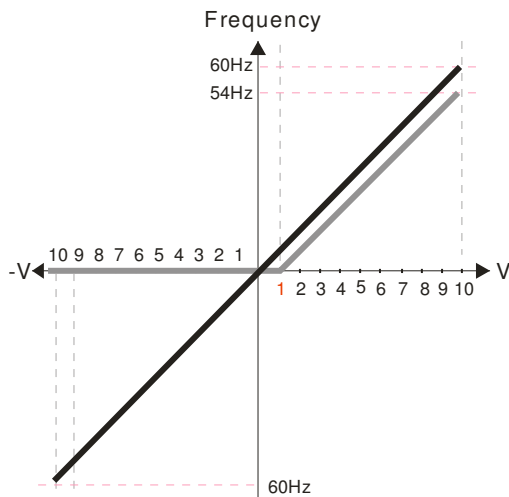

Pr.00-21=0 (Digital keypad control and d run in FWD direction)

Pr.03-05 Analog Positive Voltage Input Bias (AUI) = 10%

Pr.03-07~03-09 (Positive/Negative Bias Mode)

- 0: No bias
- 1: Lower than or equal to bias
- 2: Greater than or equal to bias
- 3: The absolute value of the bias voltage while serving as the center
- 4: Serve bias as the center

Pr.03-10 (Analog Frequency Command for Reverse Run)

- 0: Negative frequency is not valid. Forward and reverse run is controlled by digital keypad or external terminal.
- 1: Negative frequency is valid. Positive frequency = forward run; negative frequency = reverse run. Direction can not be switched by digital keypad or external terminal control.

Pr.00-13 Analog Positive Input Gain (AUI)= 100%

Pr.03-14 Analog Negative Input Gain (AUI)= 100%

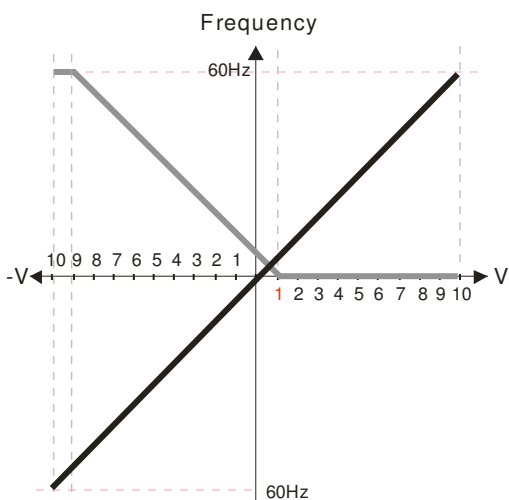

Pr.00-21=0 (Digital keypad control and d run in FWD direction)

Pr.03-05 Analog Positive Voltage Input Bias (AUI) = 10%

Pr.03-07~03-09 (Positive/Negative Bias Mode)

- 0: No bias
- 1: Lower than or equal to bias
- 2: Greater than or equal to bias
- 3: The absolute value of the bias voltage while serving as the center
- 4: Serve bias as the center

Pr.03-10 (Analog Frequency Command for Reverse Run)

- 0: Negative frequency is not valid. Forward and reverse run is controlled by digital keypad or external terminal.
- 1: Negative frequency is valid. Positive frequency = forward run; negative frequency = reverse run. Direction can not be switched by digital keypad or external terminal control.

Pr.00-13 Analog Positive Input Gain (AUI)= 100%

Pr.03-14 Analog Negative Input Gain (AUI)= 100%

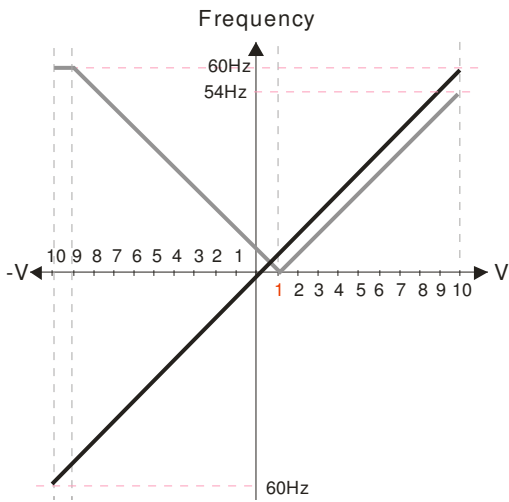

- Pr.00-21=0 (Digital keypad control and d run in FWD direction)
- Pr.03-05 Analog Positive Voltage Input Bias (AUI) = 10%
- Pr.03-07~03-09 (Positive/Negative Bias Mode)
 - 0: No bias
 - 1: Lower than or equal to bias
 - 2: Greater than or equal to bias
 - 3: The absolute value of the bias voltage while serving as the center
 - 4: Serve bias as the center

- Pr.03-10 (Analog Frequency Command for Reverse Run)
 - 0: Negative frequency is not valid. Forward and reverse run is controlled by digital keypad or external terminal.
 - 1: Neagative frequency is valid. Positive frequency = forward run; negative frequency = reverse run. Direction can not be switched by digital keypad or external terminal control.

Pr.00-13 Analog Positive Input Gain (AUI)= 100%
 Pr.03-14 Analog Negative Input Gain (AUI)= 100%

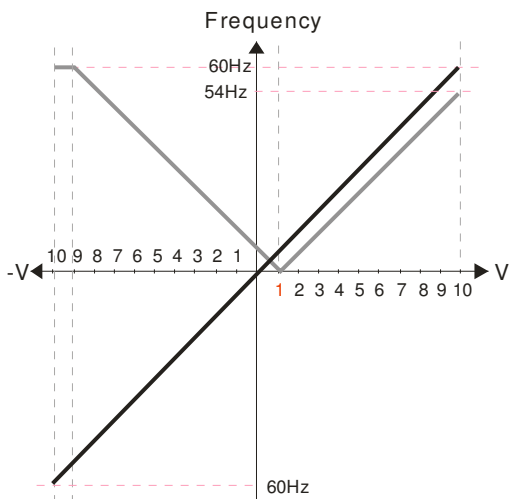

- Pr.00-21=0 (Digital keypad control and d run in FWD direction)
- Pr.03-05 Analog Positive Voltage Input Bias (AUI) = 10%
- Pr.03-07~03-09 (Positive/Negative Bias Mode)
 - 0: No bias
 - 1: Lower than or equal to bias
 - 2: Greater than or equal to bias
 - 3: The absolute value of the bias voltage while serving as the center
 - 4: Serve bias as the center

- Pr.03-10 (Analog Frequency Command for Reverse Run)
 - 0: Negative frequency is not valid. Forward and reverse run is controlled by digital keypad or external terminal.
 - 1: Neagative frequency is valid. Positive frequency = forward run; negative frequency = reverse run. Direction can not be switched by digital keypad or external terminal control.

Pr.00-13 Analog Positive Input Gain (AUI)= 100%
 Pr.03-14 Analog Negative Input Gain (AUI)= 100%

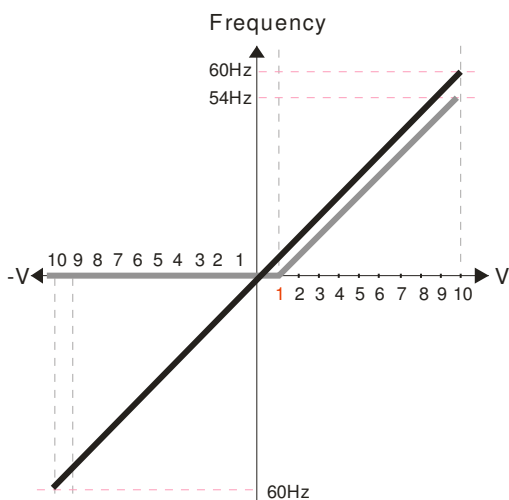

- Pr.00-21=0 (Digital keypad control and run in FWD direction)
- Pr.03-05 Analog Positive Voltage Input Bias (AUI) = 10%
- Pr.03-07~03-09 (Positive/Negative Bias Mode)
 - 0: No bias
 - 1: Lower than or equal to bias
 - 2: Greater than or equal to bias
 - 3: The absolute value of the bias voltage while serving as the center
 - 4: Serve bias as the center

- Pr.03-10 (Analog Frequency Command for Reverse Run)
 - 0: Negative frequency is not valid. Forward and reverse run is controlled by digital keypad or external terminal.
 - 1: Neagative frequency is valid. Positive frequency = forward run; negative frequency = reverse run. Direction can not be switched by digital keypad or external terminal control.

Pr.00-13 Analog Positive Input Gain (AUI)= 100%
 Pr.03-14 Analog Negative Input Gain (AUI)= 100%

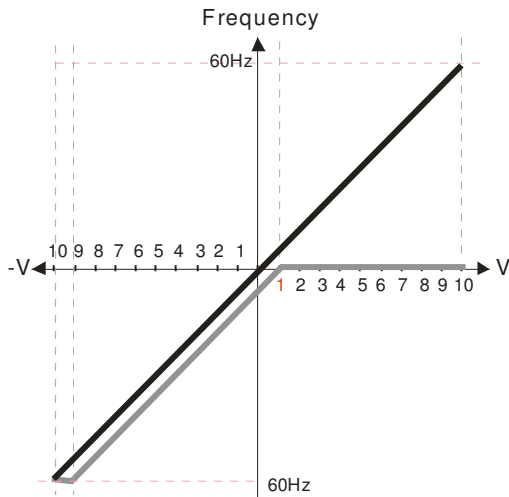

Pr.00-21=0 (Digital keypad control and run in FWD direction)
 Pr.03-05 Analog Positive Voltage Input Bias (AUI) = 10%
 Pr.03-07~03-09 (Positive/Negative Bias Mode)
 0: No bias
 1: Lower than or equal to bias
 2: Greater than or equal to bias
 3: The absolute value of the bias voltage while serving as the center
 4: Serve bias as the center

Pr.03-10 (Analog Frequency Command for Reverse Run)
 0: Negative frequency is not valid. Forward and reverse run is controlled by digital keypad or external terminal.
 1: Negative frequency is valid. Positive frequency = forward run; negative frequency = reverse run. Direction can not be switched by digital keypad or external terminal control.

Pr.00-13 Analog Positive Input Gain (AUI)= 100%
 Pr.03-14 Analog Negative Input Gain (AUI)= 100%

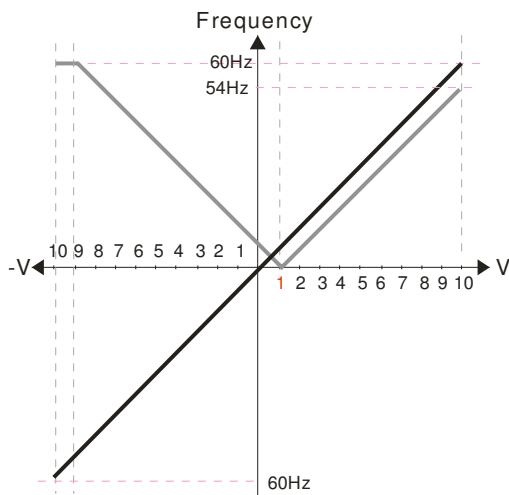

Pr.00-21=0 (Digital keypad control and run in FWD direction)
 Pr.03-05 Analog Positive Voltage Input Bias (AUI) = 10%
 Pr.03-07~03-09 (Positive/Negative Bias Mode)
 0: No bias
 1: Lower than or equal to bias
 2: Greater than or equal to bias
 3: The absolute value of the bias voltage while serving as the center
 4: Serve bias as the center

Pr.03-10 (Analog Frequency Command for Reverse Run)
 0: Negative frequency is not valid. Forward and reverse run is controlled by digital keypad or external terminal.
 1: Negative frequency is valid. Positive frequency = forward run; negative frequency = reverse run. Direction can not be switched by digital keypad or external terminal control.

Pr.00-13 Analog Positive Input Gain (AUI)= 100%
 Pr.03-14 Analog Negative Input Gain (AUI)= 100%

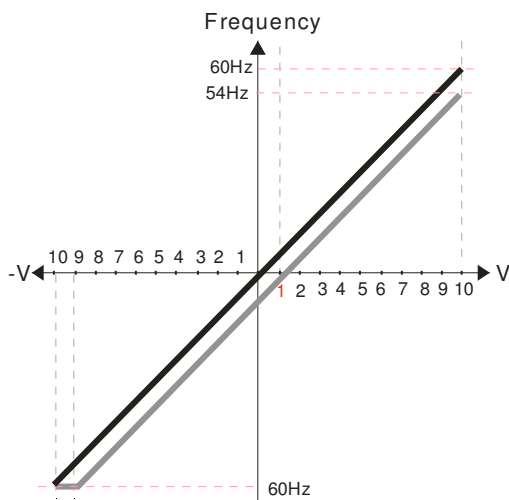

Pr.00-21=0 (Digital keypad control and run in FWD direction)
 Pr.03-05 Analog Positive Voltage Input Bias (AUI) = 10%
 Pr.03-07~03-09 (Positive/Negative Bias Mode)
 0: No bias
 1: Lower than or equal to bias
 2: Greater than or equal to bias
 3: The absolute value of the bias voltage while serving as the center
 4: Serve bias as the center

Pr.03-10 (Analog Frequency Command for Reverse Run)
 0: Negative frequency is not valid. Forward and reverse run is controlled by digital keypad or external terminal.
 1: Negative frequency is valid. Positive frequency = forward run; negative frequency = reverse run. Direction can not be switched by digital keypad or external terminal control.

Pr.00-13 Analog Positive Input Gain (AUI)= 100%
 Pr.03-14 Analog Negative Input Gain (AUI)= 100%

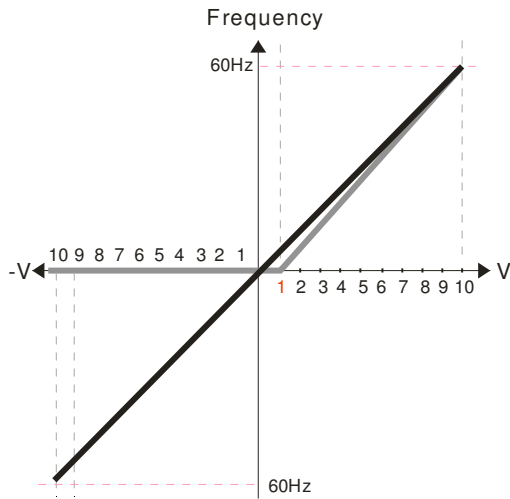

Pr.00-21=0 (Digital keypad control and run in FWD direction)
 Pr.03-05 Analog Positive Voltage Input Bias (AUI) = 10%
 Pr.03-07~03-09 (Positive/Negative Bias Mode)
 0: No bias
 1: Lower than or equal to bias
 2: Greater than or equal to bias
 3: The absolute value of the bias voltage while serving as the center
 4: Serve bias as the center

Pr.03-10 (Analog Frequency Command for Reverse Run)
 0: Negative frequency is not valid. Forward and reverse run is controlled by digital keypad or external terminal.
 1: Neagative frequency is valid. Positive frequency = forward run; negative frequency = reverse run. Direction can not be switched by digital keypad or external teriminal control.

Pr.00-13 Analog Positive Input Gain (AUI)= 111.1%
 $(10/9) * 100\% = 111.1\%$

Pr.00-14 Analog Negative Input Gain (AUI) = 100%

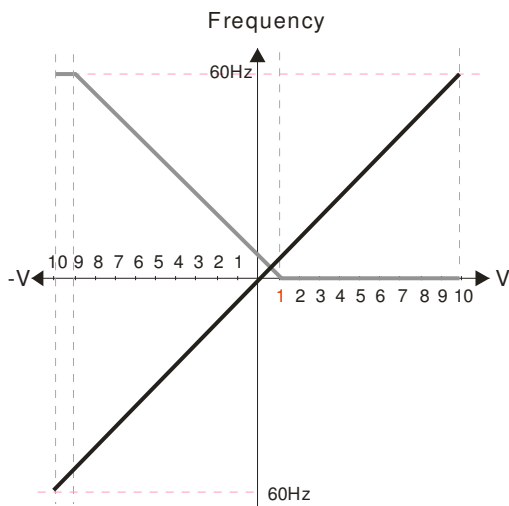

Pr.00-21=0 (Digital keypad control and run in FWD direction)
 Pr.03-05 Analog Positive Voltage Input Bias (AUI) = 10%
 Pr.03-07~03-09 (Positive/Negative Bias Mode)
 0: No bias
 1: Lower than or equal to bias
 2: Greater than or equal to bias
 3: The absolute value of the bias voltage while serving as the center
 4: Serve bias as the center

Pr.03-10 (Analog Frequency Command for Reverse Run)
 0: Negative frequency is not valid. Forward and reverse run is controlled by digital keypad or external terminal.
 1: Neagative frequency is valid. Positive frequency = forward run; negative frequency = reverse run. Direction can not be switched by digital keypad or external teriminal control.

Pr.00-13 Analog Positive Input Gain (AUI)= 111.1%
 $(10/9) * 100\% = 111.1\%$

Pr.00-14 Analog Negative Input Gain (AUI) = 100%

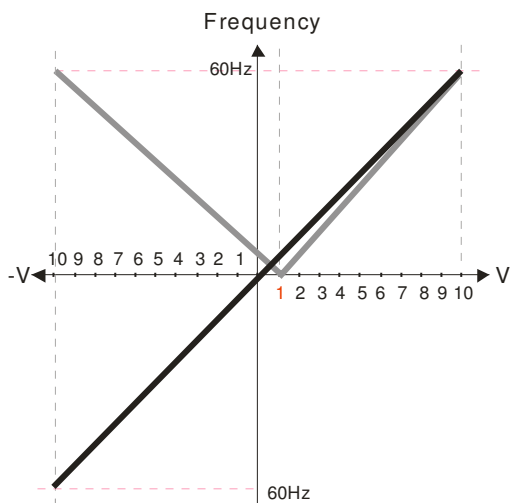

Pr.00-21=0 (Digital keypad control and run in FWD direction)
 Pr.03-05 Analog Positive Voltage Input Bias (AUI) = 10%
 Pr.03-07~03-09 (Positive/Negative Bias Mode)
 0: No bias
 1: Lower than or equal to bias
 2: Greater than or equal to bias
 3: The absolute value of the bias voltage while serving as the center
 4: Serve bias as the center

Pr.03-10 (Analog Frequency Command for Reverse Run)
 0: Negative frequency is not valid. Forward and reverse run is controlled by digital keypad or external terminal.
 1: Neagative frequency is valid. Positive frequency = forward run; negative frequency = reverse run. Direction can not be switched by digital keypad or external teriminal control.

Pr.00-13 Analog Positive Input Gain (AUI)= 111.1%
 $(10/9) * 100\% = 111.1\%$

Pr.00-14 Analog Negative Input Gain (AUI) = 100%

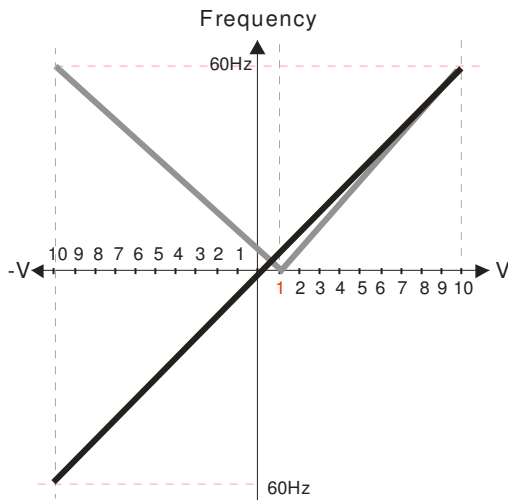

- Pr.00-21=0 (Digital keypad control and run in FWD direction)
- Pr.03-05 Analog Positive Voltage Input Bias (AUI) = 10%
- Pr.03-07~03-09 (Positive/Negative Bias Mode)
 - 0: No bias
 - 1: Lower than or equal to bias
 - 2: Greater than or equal to bias
 - 3: The absolute value of the bias voltage while serving as the center
 - 4: Serve bias as the center

- Pr.03-10 (Analog Frequency Command for Reverse Run)
 - 0: Negative frequency is not valid. Forward and reverse run is controlled by digital keypad or external terminal.
 - 1: Neagative frequency is valid. Positive frequency = forward run; negative frequency = reverse run. Direction can not be switched by digital keypad or external teriminal control.

Pr.00-13 Analog Positive Input Gain (AUI)= 111.1%
 $(10/9) * 100\% = 111.1\%$
 Pr.00-14 Analog Negative Input Gain (AUI) = 100%

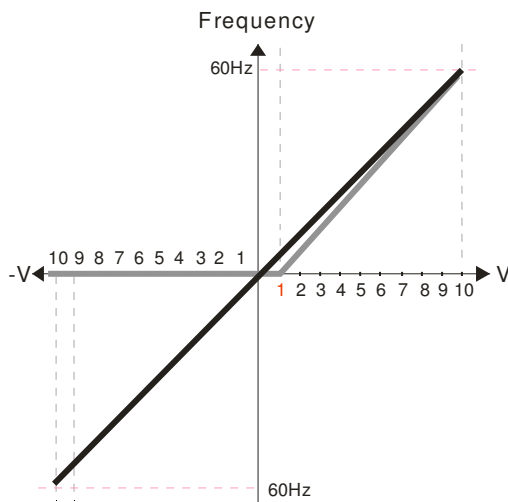

- Pr.00-21=0 (Digital keypad control and run in FWD direction)
- Pr.03-05 Analog Positive Voltage Input Bias (AUI) = 10%
- Pr.03-07~03-09 (Positive/Negative Bias Mode)
 - 0: No bias
 - 1: Lower than or equal to bias
 - 2: Greater than or equal to bias
 - 3: The absolute value of the bias voltage while serving as the center
 - 4: Serve bias as the center

- Pr.03-10 (Analog Frequency Command for Reverse Run)
 - 0: Negative frequency is not valid. Forward and reverse run is controlled by digital keypad or external terminal.
 - 1: Neagative frequency is valid. Positive frequency = forward run; negative frequency = reverse run. Direction can not be switched by digital keypad or external teriminal control.

Pr.00-13 Analog Positive Input Gain (AUI)= 111.1%
 $(10/9) * 100\% = 111.1\%$
 Pr.00-14 Analog Negative Input Gain (AUI) = 90.9%
 $(10/11) * 100\% = 90.9\%$

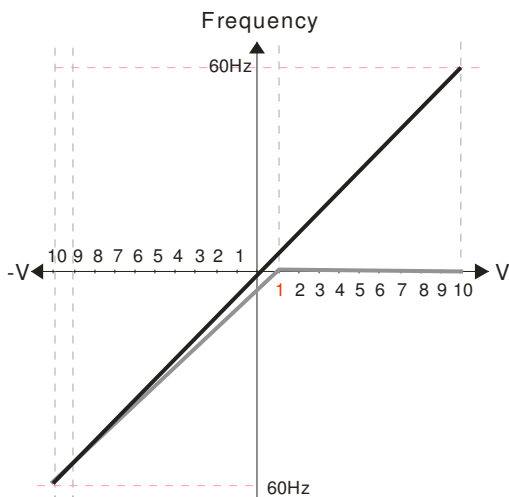

- Pr.00-21=0 (Digital keypad control and run in FWD direction)
- Pr.03-05 Analog Positive Voltage Input Bias (AUI) = 10%
- Pr.03-07~03-09 (Positive/Negative Bias Mode)
 - 0: No bias
 - 1: Lower than or equal to bias
 - 2: Greater than or equal to bias
 - 3: The absolute value of the bias voltage while serving as the center
 - 4: Serve bias as the center

- Pr.03-10 (Analog Frequency Command for Reverse Run)
 - 0: Negative frequency is not valid. Forward and reverse run is controlled by digital keypad or external terminal.
 - 1: Neagative frequency is valid. Positive frequency = forward run; negative frequency = reverse run. Direction can not be switched by digital keypad or external teriminal control.

Pr.00-13 Analog Positive Input Gain (AUI)= 111.1%
 $(10/9) * 100\% = 111.1\%$
 Pr.00-14 Analog Negative Input Gain (AUI) = 90.9%
 $(10/11) * 100\% = 90.9\%$

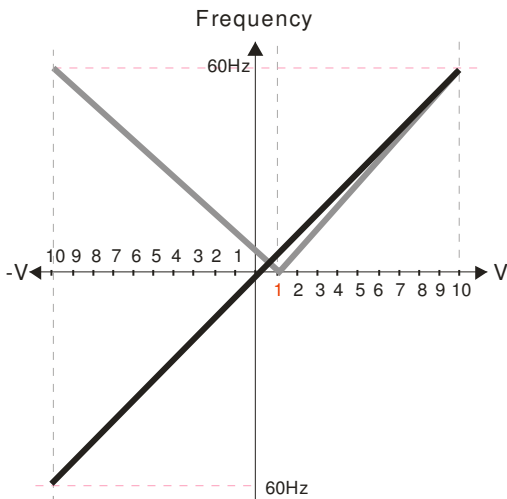

- Pr.00-21=0 (Digital keypad control and run in FWD direction)
- Pr.03-05 Analog Positive Voltage Input Bias (AUI) = 10%
- Pr.03-07~03-09 (Positive/Negative Bias Mode)
 - 0: No bias
 - 1: Lower than or equal to bias
 - 2: Greater than or equal to bias
 - 3: The absolute value of the bias voltage while serving as the center
 - 4: Serve bias as the center

- Pr.03-10 (Analog Frequency Command for Reverse Run)
 - 0: Negative frequency is not valid. Forward and reverse run is controlled by digital keypad or external terminal.
 - 1: Negative frequency is valid. Positive frequency = forward run; negative frequency = reverse run. Direction can not be switched by digital keypad or external terminal control.

Pr.00-13 Analog Positive Input Gain (AUI)= 111.1%
 $(10/9) * 100\% = 111.1\%$
 Pr.00-14 Analog Negative Input Gain (AUI) = 90.9%
 $(10/11) * 100\% = 90.9\%$

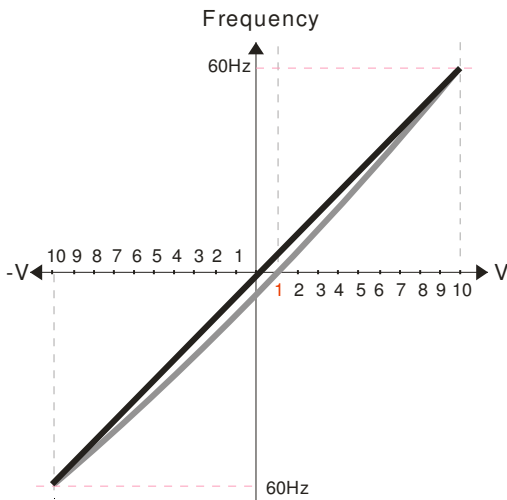

- Pr.00-21=0 (Digital keypad control and run in FWD direction)
- Pr.03-05 Analog Positive Voltage Input Bias (AUI) = 10%
- Pr.03-07~03-09 (Positive/Negative Bias Mode)
 - 0: No bias
 - 1: Lower than or equal to bias
 - 2: Greater than or equal to bias
 - 3: The absolute value of the bias voltage while serving as the center
 - 4: Serve bias as the center

- Pr.03-10 (Analog Frequency Command for Reverse Run)
 - 0: Negative frequency is not valid. Forward and reverse run is controlled by digital keypad or external terminal.
 - 1: Negative frequency is valid. Positive frequency = forward run; negative frequency = reverse run. Direction can not be switched by digital keypad or external terminal control.

Pr.00-13 Analog Positive Input Gain (AUI)= 111.1%
 $(10/9) * 100\% = 111.1\%$
 Pr.00-14 Analog Negative Input Gain (AUI) = 90.9%
 $(10/11) * 100\% = 90.9\%$

03-10 Analog Frequency Command for Reverse Run

Factory Setting: 0

- Settings
- 0: Negative frequency is not valid. Forward and reverse run is controlled by digital keypad or external terminal.
 - 1: Negative frequency is valid. Positive frequency = forward run; negative frequency = reverse run. Run direction can not be switched by digital keypad or the external terminal control.

Parameter 03-10 is used to enable reverse run command when a negative frequency (negative bias and gain) is input to AVI or ACI analog signal input.

↗ **03-11** Analog Input Gain (AVI)

↗ **03-12** Analog Input Gain (ACI)

↗ **03-13** Analog Positive Input Gain (AUI)

↗ **03-14** Analog Negative Input Gain (AUI)

Factory Setting: 100.0

Settings -500.0~500.0%

📖 Parameters 03-03 to 03-14 are used when the source of frequency command is the analog voltage/current signal.

↗ **03-15** Analog Input Filter Time (AVI)

↗ **03-16** Analog Input Filter Time (ACI)

↗ **03-17** Analog Input Filter Time (AUI)

Factory Setting: 0.10

Settings 0.00~2.00 sec.

📖 These input delays can be used to filter noisy analog signal.

📖 When the setting of the time constant is too large, the control will be stable but the control response will be slow. When the setting of time constant is too small, the control response will be faster but the control may be unstable. To find the optimal setting, please adjust the setting according to the control stable or response status.

↗ **03-18** Addition Function of the Analog Input

Factory Setting: 0

Settings 0: Disable (AVI, ACI, AUI)

1: Enable

📖 When Pr.03-18 is set to 0 and the analog input setting is the same, the priority for AVI, ACI and AUI are AVI>ACI>AUI.

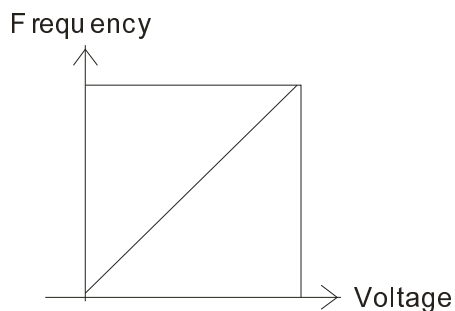

$$F_{\text{command}} = [(a_y - \text{bias}) * \text{gain}] * \frac{F_{\text{max}}(01-00)}{10\text{V or }16\text{mA}}$$

F_{command} : the corresponding frequency for 10V or 20mA
 a_y : 10 or 16mA
 bias: Pr.03-03, Pr. 03-04, Pr.03-05
 gain: Pr.03-11, Pr.03-12, Pr.03-13, Pr.03-14

↗ **03-19** Treatment to 4-20mA Analog Input Signal Loss

Factory Setting: 0

Settings 0: Disable

1: Continue operation at the last frequency

2: Decelerate to stop

3: Stop immediately and display ACE

📖 This parameter determines the behavior when 4~20mA signal is loss, when AVI(Pr.03-28=2) or ACI (03-29=0).

📖 When Pr.03-28 is not set to 2, it means the voltage input to AVI terminal is 0-10V or 0-20mA. At this moment, Pr.03-19 will be invalid.

📖 When Pr.03-29 is set to 1, it means the voltage input to ACI terminal is for 0-10V. At this moment, Pr.03-19 will be invalid.

📖 When setting is 1 or 2, it will display warning code “AnL” on the keypad. It will be blinking until the loss of the ACI signal is recovered or drive is stop.

↙ 03-20 Multi-function Output 1 (AFM1)	Factory Setting: 0
↙ 03-23 Multi-function Output 2 (AFM2)	Factory Setting: 0

Settings 0~23

Function Chart

Settings	Functions	Descriptions
0	Output frequency (Hz)	Max. frequency Pr.01-00 is regarded as 100%.
1	Frequency command (Hz)	Max. frequency Pr.01-00 is regarded as 100%.
2	Motor speed (Hz)	600Hz is regarded as 100%
3	Output current (rms)	(2.5 X rated current) is regarded as 100%
4	Output voltage	(2 X rated voltage) is regarded as 100%
5	DC Bus Voltage	450V (900V)=100%
6	Power factor	-1.000~1.000=100%
7	Power	Rated power is regarded as 100%
8	Output torque	Full-load torque is regarded as 100%
9	AVI	0~10V=0~100%
10	ACI	0~20mA=0~100%
11	AUI	-10~10V=0~100%
12	q-axis current (Iq)	(2.5 X rated current) is regarded as 100%
13	q-axis feedback value (Iq)	(2.5 X rated current) is regarded as 100%
14	d-axis current (Id)	(2.5 X rated current) is regarded as 100%
15	d-axis feedback value (Id)	(2.5 X rated current) is regarded as 100%
16	q-axis voltage (Vq)	250V (500V) =100%
17	d-axis voltage(Vd)	250V (500V) =100%
18	Torque command	Rated torque is regarded as 100%
19	Reserved	
20	Output for CANopen control	For CANopen analog output
21	RS485 analog output	For communication output (CMC-MOD01, CMC-EIP01, CMC-PN01, CMC-DN01)
22	Reserved	
23	Constant voltage/current output	Pr.03-32 and Pr.03-33 controls voltage/current output level 0~100% of Pr.03-32 corresponds to 0~10V of AFM1.

✎ **03-21** Gain of Analog Output 1 (AFM1)

Factory Setting: 100.0

✎ **03-24** Gain of Analog Output 2 (AFM2)

Factory Setting: 100.0

Settings 0~200.0%

📖 It is used to adjust the analog voltage level (Pr.03-20) that terminal AFM outputs.

📖 This parameter is set the corresponding voltage of the analog output 0.

✎ **03-22** Analog Output 1 when in REV Direction (AFM1)

✎ **03-25** Analog Output 2 when in REV Direction (AFM2)

Factory Setting: 0

Settings 0: Absolute value in REV direction

1: Output 0V in REV direction; output 0-10V in FWD direction

2: Output 5-0V in REV direction; output 5-10V in FWD direction

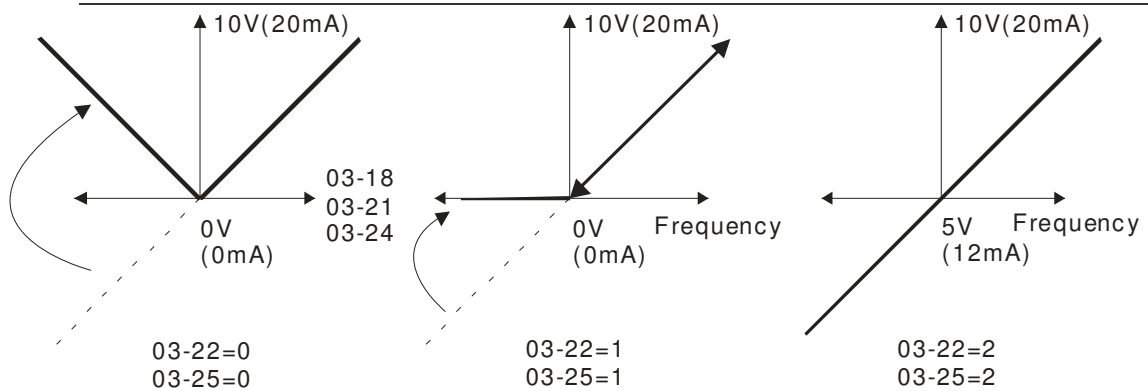

Selections for the analog output direction

03-26 Reserved

03-27 Reserved

✎ **03-28** AVI Selection

Factory Setting: 0

Settings 0: 0-10V

1: 0-20mA

2: 4-20mA

✎ **03-29** ACI Selection

Factory Setting: 0

Settings 0: 4-20mA

1: 0-10V

2: 0-20mA

📖 When changing the input mode, please check if the switch of external terminal (SW3, SW4) corresponds to the setting of Pr.03-28~03-29.

03-30 Status of PLC Output Terminal

Factory Setting: ##

Settings 0~65535

Monitor the status of PLC analog output terminals

P.03-30 shows the external multi-function output terminal that used by PLC.

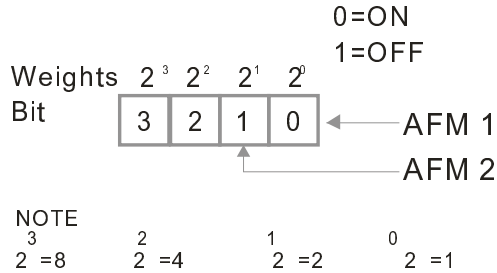

For Example:

If the value of Pr.02-30 displays 0002h(Hex), it means AFM1 and AFM2 are used by PLC.

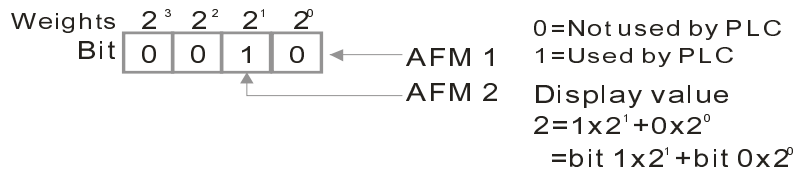

03-31 AFM2 0-20mA Output Selection

Factory Setting: 0

Settings 0: 0-20mA output

1: 4-20mA output

03-32 AFM1 DC Output Setting Level

03-33 AFM2 DC Output Setting Level

Factory Setting: 0.00

Settings 0.00~100.00%

03-34

~ Reserve

03-38

03-39 Keypad Potentiometer Selection

Factory Setting:0

Settings 0: No Function

1: Frequency Command

03-40 Keypad Potentiometer Input Bias

Factory Setting:0.0

Settings -100.0~100.0%

03-41 Keypad Potentiometer Positive/Negative Bias Mode

出廠設定値：0

- Settings
- 0: No bias
 - 1: Lower than or equal to bias
 - 2: Greater than or equal to bias
 - 3: The absolute value of the bias voltage while serving as the center
 - 4: Serve bias as the center
-

 Refer to Pr.03-07~03-09.

03-42 Keypad Potentiometer Input Gain

Factory Setting:100.0

- Settings -500.0~500.0%
-

03-43 AFM1 DC Output Setting Level Keypad Potentiometer Analog Input Filter Time

Factory Setting:0.01

- Settings 0~2.00 sec.
-

03-44 MO by AI Level

Factory Setting: 0

- Settings
- 0: AVI
 - 1: ACI
 - 2: AUI
-

03-45 AI Upper Level

Factory Setting:50.00

- Settings -100.00~100.00%
-

03-46 AI Lower Level

Factory Setting:10.00

- Settings -100.00~100.00%
-

 This function requires working with multi-function output item “67-Analog Signal Level Achieved”. The MO is active when AI input level is higher than Pr.03-45 AI Upper Level. The MO shuts off when the AI input is lower than Pr.03-46 AI Lower Level.

 AI Upper Level must be bigger than AI Lower Level.

03-47

~

Reserved

03-49

03-50 Analog Input Curve Selection

Factory Setting: 0

- Settings
- 0: Regular Curve
 - 1: 3 point curve of AVI
 - 2: 3 point curve of ACI
 - 3: 3 point curve of AVI & ACI
-

- 4: 3 point curve of AUI
- 5: 3 point curve of AVI & AUI
- 6: 3 point curve of ACI & AUI
- 7: 3 point curve of AVI & ACI & AUI

↗ **03-51** AVI Low Point Factory Setting: 0.00

Settings 03-28=0, 0.00~10.00V
03-28≠0, 0.00~20.00mA

↗ **03-52** AVI Proportional Low Point Factory Setting: 0.00

Settings 0.00~100.00%

↗ **03-53** AVI Mid Point Factory Setting: 5.00

Settings 03-28=0, 0.00~10.00V
03-28≠0, 0.00~20.00mA

↗ **03-54** AVI Proportional Mid Point Factory Setting: 50.00

Settings 0.00~100.00%

↗ **03-55** AVI High Point Factory Setting: 10.00

Settings 03-28=0, 0.00~10.00V
03-28≠0, 0.00~20.00mA

↗ **03-56** AVI Proportional High Point Factory Setting: 100.00

Settings 0.00~100.00%

- 📖 When Pr.03-28 = 0, AVI setting is 0-10V and the unit is in voltage (V).
- 📖 When Pr.03-28 ≠ 0, AVI setting is 0-20mA or 4-20mA and the unit is in current (mA).
- 📖 When setting analog input AVI to frequency command, it 100% corresponds to Fmax (Pr.01-00 Max. operation frequency).
- 📖 Three of the AVI points can be set according to user's demand on voltage(current) and proportion, there is no setting limit for ACI points.

↗ **03-57** ACI Low Point Factory Setting: 4.00

Settings Pr.03-29=1, 0.00~10.00V
Pr.03-29≠1, 0.00~20.00mA

↗ **03-58** ACI Proportional Low Point Factory Setting: 0.00

Settings 0.00~100.00%

↗	03-59 ACI Mid-Point	Factory Setting: 12.00
	Settings 03-29=1, 0.00~10.00V 03-29≠1, 0.00~20.00mA	
↗	03-60 ACI Proportional Mid-Point	Factory Setting: 50.00
	Settings 0.00~100.00%	
↗	03-61 ACI High Point	Factory Setting: 20.00
	Settings 03-29=1, 0.00~10.00V 03-29≠1, 0.00~20.00mA	
↗	03-62 ACI Proportional High Point	Factory Setting: 100.00
	Settings 0.00~100.00%	

📖 When Pr.03-29=1, ACI setting is 0-10V and the unit is in voltage (V).

📖 When Pr.03-29≠1, ACI setting is 0-20mA or 4-20mA and the unit is in current (mA).

📖 When setting analog input ACI to frequency command, it 100% corresponds to Fmax (Pr.01-00 Max. operation frequency).

📖 Three of the ACI points can be set according to user's demand on voltage (current) and proportion, there is no setting limit for ACI points.

↗	03-63 Positive AUI Voltage Low Point	Factory Setting: 0.00
	Settings 0.00~10.00V	
↗	03-64 Positive AUI Voltage Proportional Low Point	Factory Setting: 0.00
	Settings 0.00~100.00%	
↗	03-65 Positive AUI Voltage Mid Point	Factory Setting: 5.00
	Settings 0.00~10.00V	
↗	03-66 Positive AUI Voltage Proportional Mid Point	Factory Setting: 50.00
	Settings 0.00~100.00%	
↗	03-67 Positive AUI Voltage High Point	Factory Setting: 10.00
	Settings 0.00~10.00V	
↗	03-68 Positive AUI Voltage Proportional High Point	Factory Setting: 100.00
	Settings 0.00~100.00%	

📖 When setting positive voltage AUI to frequency command, it 100% corresponds to Fmax (Pr.01-00 Max. operation frequency) and the motor runs in forward direction.

📖 Three of the positive voltage AUI points can be set according to user's demand on voltage and proportion, there is no setting limit for AUI points.

↗	03-69 Negative AUI Voltage Low Point	Factory Setting: 0.00
	Settings 0.00~-10.00V	
↗	03-70 Negative AUI Voltage Proportional Low Point	Factory Setting: 0.00
	Settings 0.00~-100.00%	
↗	03-71 Negative AUI Voltage Mid Point	Factory Setting: -5.00
	Settings 0.00~-10.00V	
↗	03-72 Negative AUI Voltage Proportional Mid Point	Factory Setting: -50.00
	Settings 0.00~-100.00%	
↗	03-73 Negative AUI Voltage High Point	Factory Setting: -10.00
	Settings 0.00~-10.00V	
↗	03-74 Negative AUI Voltage Proportional High Point	Factory Setting: -100.00
	Settings 0.00~-100.00%	

📖 When setting negative voltage AUI to frequency command, it 100% corresponds to Fmax (Pr.01-00 Max. operation frequency) and the motor runs in reverse direction.

📖 Three of the negative voltage AUI points can be set according to user's demand on voltage and proportion, there is no setting limit for AUI points.

04 Multi-Step Speed Parameters

✎ This parameter can be set during operation.

✎	04-00	1st Step Speed Frequency
✎	04-01	2nd Step Speed Frequency
✎	04-02	3rd Step Speed Frequency
✎	04-03	4th Step Speed Frequency
✎	04-04	5th Step Speed Frequency
✎	04-05	6th Step Speed Frequency
✎	04-06	7th Step Speed Frequency
✎	04-07	8th Step Speed Frequency
✎	04-08	9th Step Speed Frequency
✎	04-09	10th Step Speed Frequency
✎	04-10	11th Step Speed Frequency
✎	04-11	12th Step Speed Frequency
✎	04-12	13th Step Speed Frequency
✎	04-13	14th Step Speed Frequency
✎	04-14	15th Step Speed Frequency

Factory Setting: 0.00

Settings 0.00~600.00Hz

📖 The Multi-function Input Terminals (refer to setting 1~4 of Pr.02-01~02-08 and 02-26~02-31) are used to select one of the AC motor drive Multi-step speeds(max. 15 speeds). The speeds (frequencies) are determined by Pr.04-00 to 04-14 as shown in the following.

📖 The run/stop command can be controlled by the external terminal/digital keypad/communication via Pr.00-21.

📖 Each one of multi-step speeds can be set within 0.0~600.0Hz during operation.

📖 Explanation for the timing diagram for multi-step speeds and external terminals

The Related parameter settings are:

1. Pr.04-00~04-14: setting multi-step speeds (to set the frequency of each step speed)
2. Pr.02-01~02-08, 02-26~02-31: setting multi-function input terminals (multi-step speed 1~4)
 - Related parameters: 01-22 JOG Frequency, 02-01 Multi-function Input Command 1 (MI1), 02-02 Multi-function Input Command 2 (MI2), 02-03 Multi-function Input Command 3 (MI3), 02-04 Multi-function Input Command 4 (MI4)

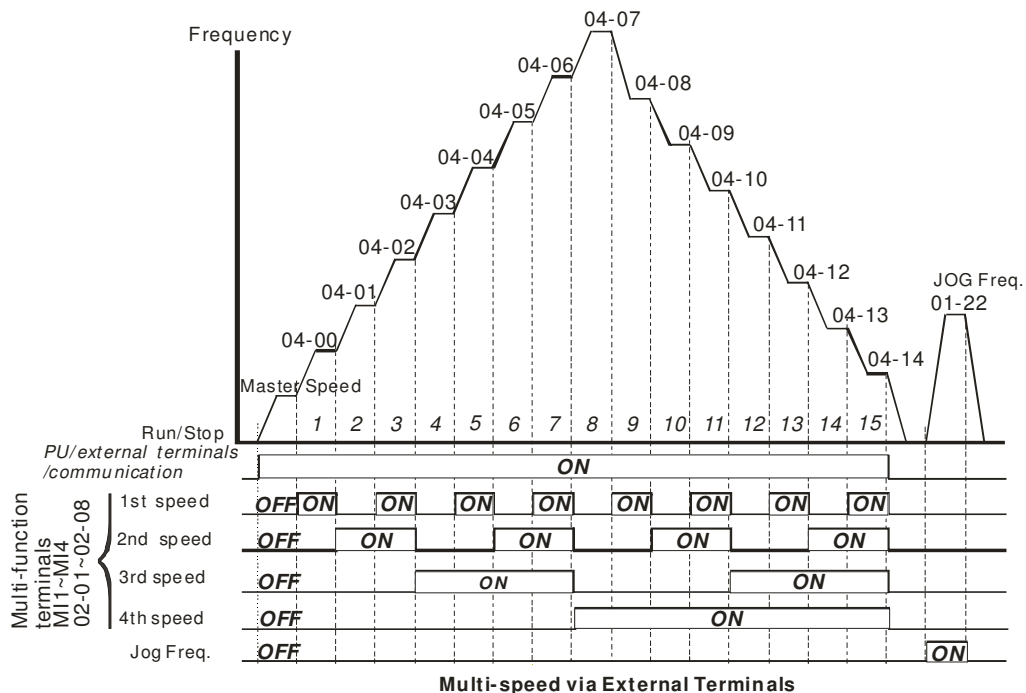

04-15

~

Reserved

04-49

04-50

PLC Buffer 0~19

~

Factory Setting: 0

04-69

Settings 0~65535

The PLC buffer can be combined with PLC or HMI programming for variety application.

05 Motor Parameters

⚡ This parameter can be set during operation.

05-00 Motor Auto Tuning

Factory Setting: 0

- Settings
- 0: No function
 - 1: Rolling test for induction motor (Rs, Rr, Lm, Lx, no-load current)
 - 2: Rolling test for induction motor
 - 3: Reserved
 - 4: Rolling test for PM motor magnetic pole
 - 5: Rolling test for PM motor
 - 6: Rolling test for IM motor flux curve
 - 7~11: Reserved
 - 12: FOC Sensorless inertia estimation
 - 13: High frequency and blocked rotor test for PM motor parameter

Induction Motor

📖 Press [Run] to begin auto tuning. The measured value will be written into motor 1 (Pr.05-05 ~05-09, Rs, Rr, Lm, Lx, no-load current) and motor 2 (Pr.05-17 to Pr.05-21) automatically.

To begin AUTO-Tuning in rolling test:

1. Make sure that all the parameters are set to factory settings and the motor wiring is correct.
2. Make sure the motor has no-load before executing auto-tuning and the shaft is not connected to any belt or gear motor. It is recommended to set to 2 if the motor can't separate from the load.
- 3.

	Motor 1 Parameter	Motor 2 Parameter
Motor Rated Frequency	01-01	01-35
Motor Rated Voltage	01-02	01-36
Motor Full-load Current	05-01	05-13
Motor Rated Power	05-02	05-14
Motor Rated Speed	05-03	05-15
Motor Pole Numbers	05-04	05-16

4. Set Pr.05-00=1 and press [Run], the drive will begin auto-tuning. Please be aware of the motor that it starts spinning as [Run] is pressed.
5. When auto-tuning is completed, please check if the measured values are written into motor 1 (Pr.05-05 ~05-09) and motor 2 (Pr.05-17 ~05-21) automatically.
6. Mechanical equivalent circuit

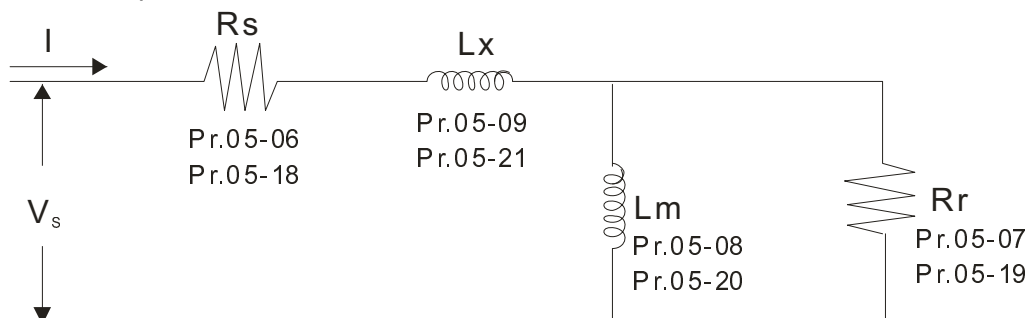

※ If Pr.05-00 is set to 2 (static test), user needs to input the no-load current value of motor into Pr.05-05 for motor 1/Pr.05-17 for motor 2.

 **NOTE**

- ☑ In torque/vector control mode, it is not recommended to have motors run in parallel.
- ☑ It is not recommended to use torque/vector control mode if motor rated power exceeds the rated power of the AC motor drive.
- ☑ When auto-tuning 2 motors, it needs to set multi-function input terminals (setting 14) or change Pr.05-22 for motor 1/motor 2 selection.
- ☑ The no-load current is usually 20~50% X rated current.
- ☑ The rated speed can not be greater than or equal to $120f/p$ (f = rated frequency Pr.01-01/01-35; P : number of motor poles Pr.05-04/05-16).

Permanent Magnet Motor (PM)

-  Set Pr.05-00= 5 or 13 and press [Run] to begin auto tuning for PM motor. The measured values will be written into Pr.05-39(Rs), Pr.05-40 & 41(Ld & Lq)and Pr.05-43(PM motor's Ke parameter).

To begin AUTO-Tuning for PM motor in rolling test:

1. Make sure all the parameters are reset to factory setting and the motor wiring installation is correct.
2. For PM motor, set Pr.05-33=1 and complete the following settings according to your motor specifications, Pr.05-34 rated current, Pr.05-35 rated power, Pr.05-36 rated speed and Pr. 05-37 pole number. The acceleration time and deceleration time should be set according to your motor capacity.
3. Set Pr.05-00 to 5 and press [Run] to begin auto tuning for PM motor. Please be aware of the motor that it starts spinning as [Run] is pressed.
4. When auto-tuning is completed, please check if the measured values are written into Pr.05-39~05-41 and Pr.05-43 automatically.

-  Set Pr.05-00=4 and press [Run] to begin auto-tuning for PM motor PG offset angle. The measured value will be written into Pr.05-42 automatically.

- ☑ Note 1: When execute auto-tuning for PM motor PG origin, please make sure the encoder setting are correct (Pr.10-00, 10-01, 10-02), otherwise the PG origin measure error and motor stall may occur.
- ☑ Note 2: If PM motor runs in an opposite direction of the drive's command, switch any two of the UVW cable and re-connect, then execute PG origin search again. It is crucial to execute auto-tuning after the switch otherwise PG origin measure error and motor stall may occur.

-  Auto-tuning process for measuring PG offset angle of PM motor:

1. Set Pr.05-00=5 and press RUN, or manually input the values into Pr. 01-01, 05-34~-541 and Pr.05-43.
2. It is strongly suggested to remove the motor and unload before begins auto-tuning.

3. Set Pr.05-00=4 and press [Run] to begin auto-tuning. Please be aware of the motor that it starts spinning as [Run] is pressed.
4. When auto-tuning is completed, please check if the PG offset angle is written into Pr.05-42 automatically.

 **NOTE**

When auto-tuning for PM motor is completed and the control mode setting is done, it is recommend to turn the drive's power off and restart again to ensure the drive operates according to the motor parameter settings.

05-01 Full-load Current of Induction Motor 1 (A)

Unit: Ampere

Factory Setting: #.##

Settings 10 to 120% of drive's rated current

 This value should be set according to the rated frequency of the motor as indicated on the motor nameplate. The factory setting is 90% X rated current.

Example: The rated current for 7.5HP (5.5kW) is 25 and factory setting is 22.5A. The range for setting will be 10~30A.(25*40%=10A and 25*120%=30A)

 **05-02** Rated Power of Induction Motor 1(kW)

Factory Setting: #.##

Settings 0~655.35 kW

 It is used to set rated power of the motor 1. The factory setting is the power of the drive.

 **05-03** Rated Speed of Induction Motor 1 (rpm)

Factory Setting:

1710 (60Hz 4 poles)

1410 (50Hz 4 poles)

Settings 0~65535

 It is used to set the rated speed of the motor and need to set according to the value indicated on the motor nameplate.

05-04 Pole Number of Induction Motor 1

Factory Setting: 4

Settings 2~20

 It is used to set the number of motor poles (must be an even number).

05-05 No-load Current of Induction Motor 1 (A)

Unit: Amper

Factory Setting: #.##

Settings 0 to the factory setting in Pr.05-01

 The factory setting is 40% X rated current.

05-06 Stator Resistance(Rs) of Induction Motor 1

05-07 Rotor Resistance(Rr) of Induction Motor 1

Factory Setting: #.###

Settings 0~65.535Ω

05-08 Magnetizing Inductance(Lm) of Induction Motor 1

05-09 Stator inductance(Lx) of Induction Motor 1

Factory Setting: #.#

Settings 0~6553.5mH

05-10

~ Reserved

05-12

05-13 Full-load Current of Induction Motor 2 (A)

Unit: Ampere

Factory Setting:#.##

Settings 10~120%

📖 This value should be set according to the rated frequency of the motor as indicated on the motor nameplate. The factory setting is 90% X rated current.

Example: The rated current for 7.5HP (5.5kW) is 25A and factory setting is 22.5A. The range for setting will be 10~30A.(25*40%=10A and 25*120%=30A)

↗ **05-14** Rated Power of Induction Motor 2 (kW)

Factory Setting: #.##

Settings 0~655.35 kW

📖 It is used to set rated power of the motor 2. The factory setting is the power of the drive.

↗ **05-15** Rated Speed of Induction Motor 2 (rpm)

Factory Setting: 1710

Settings 0~65535

📖 It is used to set the rated speed of the motor and need to set according to the value indicated on the motor nameplate.

05-16 Pole Number of Induction Motor 2

Factory Setting: 4

Settings 2~20

📖 It is used to set the number of motor poles (must be an even number).

05-17 No-load Current of Induction Motor 2 (A)

Unit: Ampere

Factory Setting: #.##

Settings 0 to the factory setting in Pr.05-01

📖 The factory setting is 40% X rated current.

05-18 Stator Resistance (Rs) of Induction Motor 2**05-19** Rotor Resistance (Rr) of Induction Motor 2

Factory Setting: #.###

Settings 0~65.535Ω

05-20 Magnetizing Inductance (Lm) of Induction Motor 2**05-21** Stator Inductance (Lx) of Induction Motor 2

Factory Setting: #.#

Settings 0~6553.5 mH

05-22 Induction Motor 1/ 2 Selection

Factory Setting: 1

Settings 1: Motor 1

2: Motor 2

📖 It is used to set the motor that driven by the AC motor drive.

⚡ **05-23** Frequency for Y-connection/Δ-connection Switch of Induction Motor

Factory Setting: 60.00

Settings 0.00~600.00Hz

05-24 Y-connection/Δ-connection Switch of Induction Motor IM

Factory Setting: 0

Settings 0: Disable

1: Enable

⚡ **05-25** Delay Time for Y-connection/Δ-connection Switch of Induction Motor

Factory Setting: 0.200

Settings 0.000~60.000 sec.

📖 P.05-23 and Pr.05-25 are applied in the wide range motors and the motor coil will execute the switch of Y-connection/Δ-connection as required. (The wide range motors has relation with the motor design. In general, it has higher torque at low speed and Y-connection and it has higher speed at high speed and Δ-connection.)

📖 Pr.05-24 is used to enable/disable Y-connection/Δ-connection Switch.

📖 When Pr.05-24 is set to 1, the drive will select by Pr.05-23 setting and current motor frequency to switch motor to Y-connection or Δ-connection. At the same time, it will also affect motor parameters.

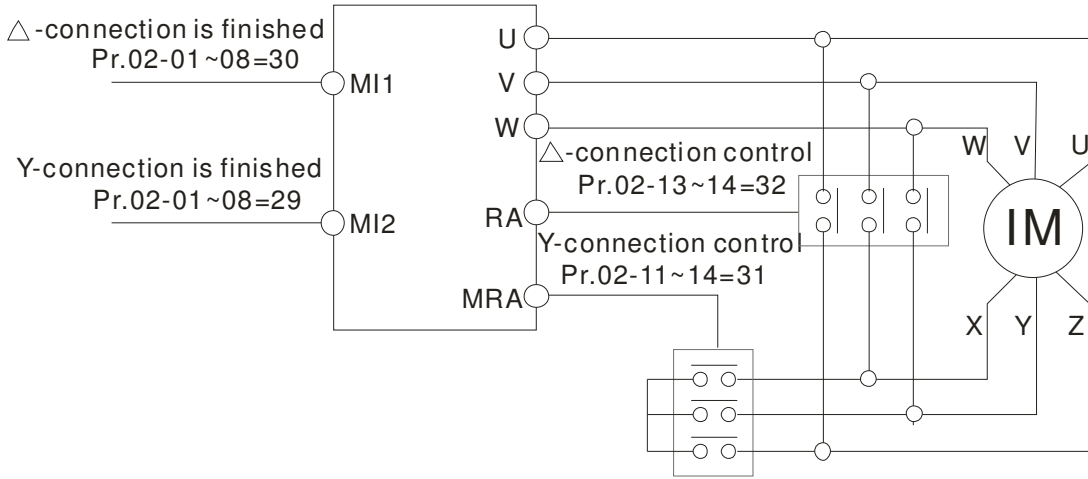

📖 Pr.05-25 is used to set the switch delay time of Y-connection/Δ-connection.

📖 When output frequency reaches Y-connection/Δ-connection switch frequency, drive will delay by Pr.05-25 before multi-function output terminals are active.

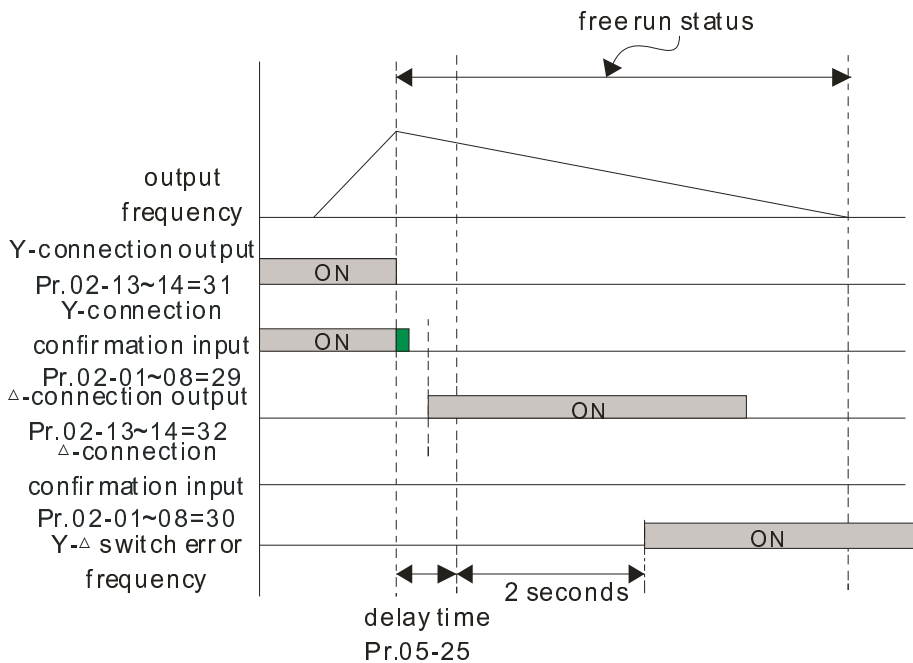
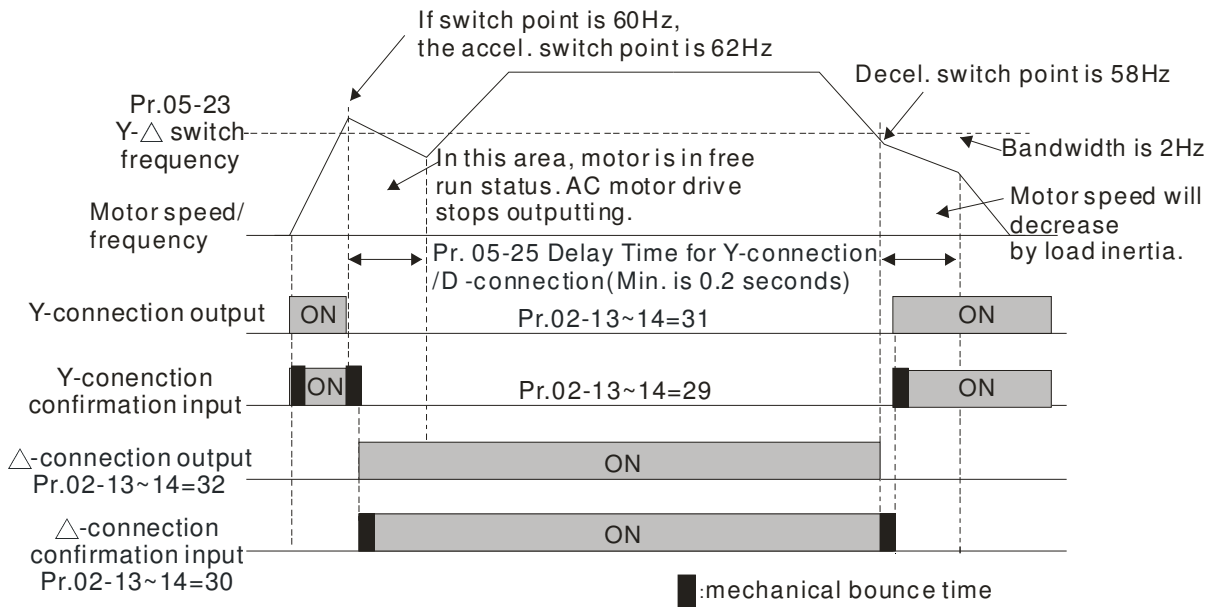

Y- Δ connection switch: can be used for wide range motor
 Y-connection for low speed: higher torque can be used for rigid tapping
 Δ-connection for high speed: higher torque can be used for high-speed drilling



05-26	Accumulative Watt Per Second of Motor in Low Word (W-sec)	Factory Setting: #.#
	Settings Read only	
05-27	Accumulative Watt Per Second of Motor in High Word (W-sec)	Factory Setting: #.#
	Settings Read only	
05-28	Accumulative Watt-hour of Motor (W-Hour)	Factory Setting: #.#
	Settings Read only	
05-29	Accumulative Watt-hour of Motor in Low Word (KW-Hour)	Factory Setting: #.#
	Settings Read only	
05-30	Accumulative Watt-hour of Motor in High Word (KW-Hour)	Factory Setting: #.#
	Settings Read only	
	Pr.05-26~05-29 records the amount of power consumed by motors. The accumulation begins when the drive is activated and record is saved when the drive stops or turns OFF. The amount of consumed watts will continue to accumulate when the drive activate again. To clear the accumulation, set Pr.00-02 to 5 then the accumulation record will return to 0.	
05-31	Accumulative Motor Operation Time (Min)	Factory Setting: 0
	Settings 00~1439	
05-32	Accumulative Motor Operation Time (day)	Factory Setting: 0
	Settings 00~65535	
	Pr. 05-31 and Pr.05-32 are used to record the motor operation time. To clear the operation time, set Pr.05-31 and Pr.05-32 to 00. Operation time shorter than 60 seconds will not be recorded.	
05-33	Induction Motor (IM) and Permanent Magnet Motor Selection	Factory Setting: 0
	Settings 0: Induction Motor 1: Permanent Magnet Motor	
05-34	Full-load current of Permanent Magnet Motor	Factory Setting: 0.00
	Settings 0.00~655.35 Amps	
05-35	Rated Power of Permanent Magnet Motor	Factory Setting: 0.00
	Settings 0.00~655.35 kW	
05-36	Rated speed of Permanent Magnet Motor	Factory Setting: 2000
	Settings 0~65535 rpm	

05-37 Pole number of Permanent Magnet Motor

Factory Setting: 10

Settings 0~65535

05-38 Inertia of Permanent Magnet Motor

Factory Setting: 0.0

Settings 0.0~6553.5 kg.cm² (0.0001kg.m²)

📖 This parameter setting is defined in **kg-cm²**. If this measure is not familiar to you, please refer to the chart below. (Delta's motor inertia chart is for reference purpose only.)

Delta Motor (Low inertia model)

Rated Power(kW)	0.1	0.2	0.4	0.4	0.75	1	2
Rotor inertia (kg.m ²)	3.70E-06	1.77E-05	2.77E-05	6.80E-05	1.13E-04	2.65E-04	4.45E-04

Delta Motor (Mid to High Inertia model)

Rated Power(kW)	0.5	1	1.5	2	2	0.3	0.6	0.9
Rotor inertia (kg.m ²)	8.17E-04	8.41E-04	1.12E-03	1.46E-03	3.47E-03	8.17E-04	8.41E-04	1.12E-03

※ For more information on motor inertia value, please refer to Pr.11-01.

05-39 Stator Resistance of PM Motor

Factory Setting: 0.000

Settings 0.000~65.535Ω

05-40 Permanent Magnet Motor Ld

Factory Setting: 0.00

Settings 0.00~655.35 mH

05-41 Permanent Magnet Motor Lq

Factory Setting: 0.00

Settings 0.00~655.35 mH

05-42 PG Offset angle of PM Motor

Factory Setting: 0

Settings 0.0~360.0°

📖 When Pr.05-00 is set to 4, the drive will detect offset angle and write into Pr.05-42.

05-43 Ke parameter of PM Motor

Unit: V/1000rpm

Factory Setting: 0

Settings 0~65535

06 Protection Parameters

⚡ This parameter can be set during operation.

⚡ 06-00 Low Voltage Level

Settings 230V Series: 150.0~ 220.0 Vdc
460V Series: 300.0~440.0V

Factory Setting:
180.0
360.0

📖 It is used to set the Lv level. When the drive is in the low voltage, it will stop output and free to stop.

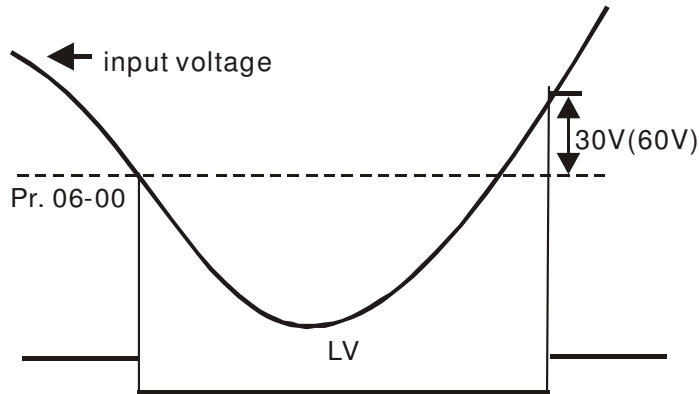

⚡ 06-01 Over-voltage Stall Prevention

Settings 230V Series: 0.0~450.0V
460V Series: 0.0~900.0V
0: Disabled

Factory Setting: 380.0/760.0

- 📖 When Pr.06-01 is set to 0.0, the over-voltage stall prevention function is disabled. When braking units or resistors are connected to the drive, this setting is suggested.
- 📖 During deceleration, the DC bus voltage may exceed its Maximum Allowable Value due to motor regeneration. When this function is enabled, the AC motor drive will not decelerate further and keep the output frequency constant until the voltage drops below the preset value again.
- 📖 This function is used for the occasion that the load inertia is unsure. When it stops in the normal load, the over-voltage won't occur during deceleration and fulfill the setting of deceleration time. Sometimes, it may not stop due to over-voltage during decelerating to stop when increasing the load regenerative inertia. At this moment, the AC drive will auto add the deceleration time until drive stop.
- 📖 When the over-voltage stall prevention is enabled, drive deceleration time will be larger than the setting.
- 📖 When there is any problem as using deceleration time, refer to the following items to solve it.
 1. Add the suitable deceleration time.
 2. Add brake resistor (refer to Chapter 6-1 for details) to consume the electrical energy that regenerated from the motor with heat type.
- Related parameters: Pr.01-13, 01-15, 01-17, 01-19 (settings of decel. time 1~4), Pr.02-13~02-14 (Multi-function Output 1 RY1, RY2), Pr. 02-16~02-17 Multi-function Output (MO1, 2)

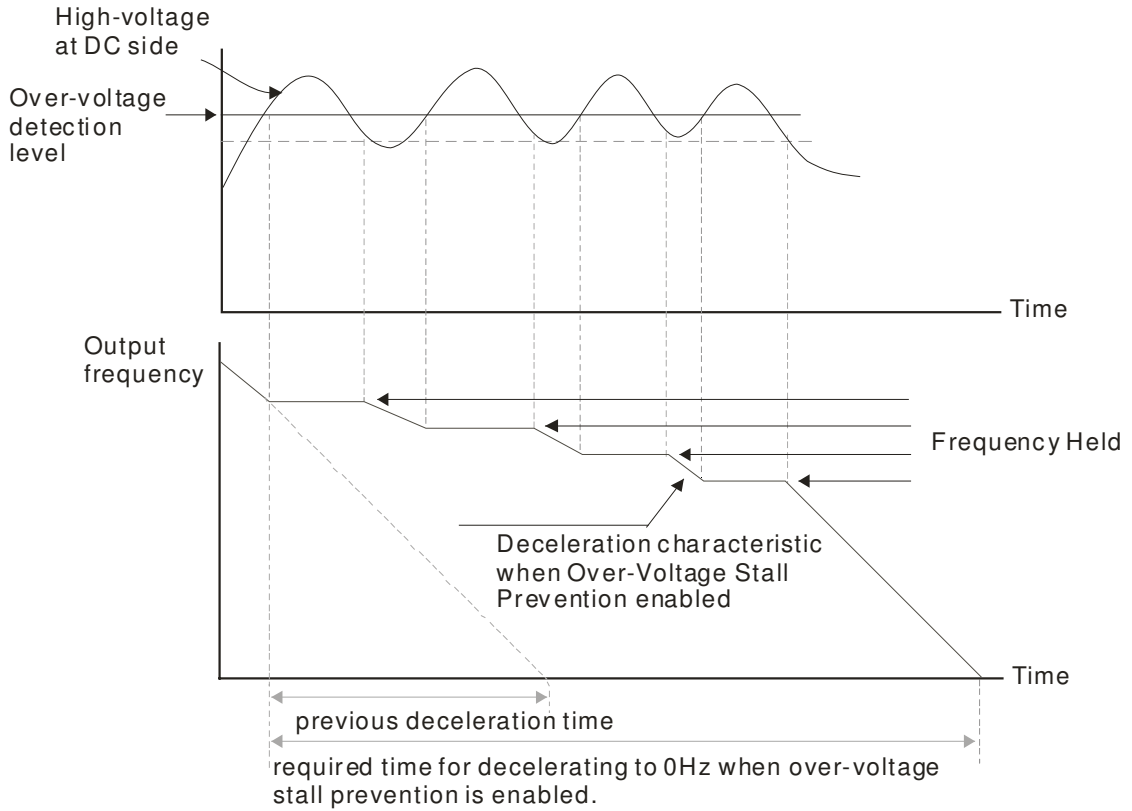

06-02 Selection for Over-voltage Stall Prevention

Factory Setting: 0

- Settings 0: Traditional over-voltage stall prevention
- 1: Smart over-voltage prevention

When Pr.06-02 is set to 1, the drive will maintain DCbus voltage when decelerating and prevent OV.

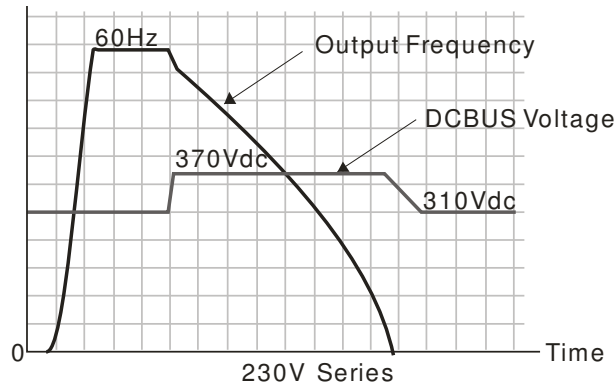

06-03 Over-current Stall Prevention during Acceleration

- Settings Normal duty: 0~160% (100%: drive's rated current) Factory Setting: 120
- Heavy duty: 0~180% (100%: drive's rated current) Factory Setting: 150

If the motor load is too large or drive acceleration time is too short, the AC drive output current may increase abruptly during acceleration and it may cause motor damage or trigger protection functions (OL or OC). This parameter is used to prevent this situation.

During acceleration, the AC drive output current may increase abruptly and exceed the value specified by Pr.06-03 due to rapid acceleration or excessive load on the motor. When this

function is enabled, the AC drive will stop accelerating and keep the output frequency constant until the current drops below the maximum value.

- 📖 When the over-current stall prevention is enabled, drive deceleration time will be larger than the setting.
- 📖 When the Over-Current Stall Prevention occurs due to too small motor capacity or in the factory setting, please decrease Pr.06-03 setting.
- 📖 When there is any problem by using acceleration time, refer to the following items to solve it.
- 📖 Related parameters: Pr.01-12, 01-14, 01-16, 01-18 (settings of accel. time 1~4), Pr.01-44
 1. dd the suitable acceleration time.
 2. Setting Pr.01-44 Optimal Acceleration/Deceleration Setting to 1, 3 or 4 (auto accel.)
- 📖 Optimal Acceleration/Deceleration Setting, Pr.02-13~02-14 (Multi-function Output 1 RY1, RY2), Pr. 02-16~02-17 Multi-function Output (MO1, 2)

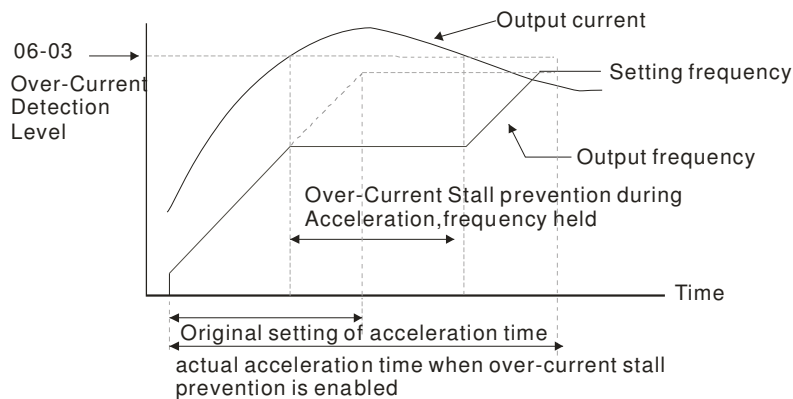

🔧 06-04 Over-current Stall Prevention during Operation

Settings	Normal duty: 0~160% (100%: drive's rated current)	Factory Setting: 120
	Heavy duty: 0~180% (100%: drive's rated current)	Factory Setting: 150

- 📖 It is a protection for drive to auto decrease output frequency when the motor is over-load abruptly during motor constant operation.
- 📖 If the output current exceeds the setting specified in Pr.06-04 when the drive is operating, the drive will decrease its output frequency (according to Pr.06-05) to prevent the motor stall. If the output current is lower than the setting specified in Pr.06-04, the drive will accelerate (according to Pr.06-05) again to catch up with the set frequency command value.

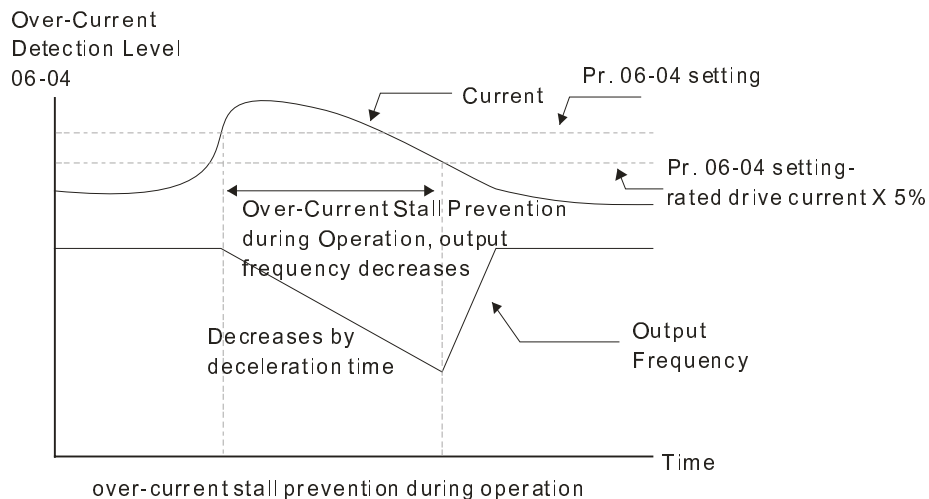

↗ **06-05** Accel./Decel. Time Selection of Stall Prevention at Constant Speed

Factory Setting: 0

- Settings
- 0: by current accel/decel time
 - 1: by the 1st accel/decel time
 - 2: by the 2nd accel/decel time
 - 3: by the 3rd accel/decel time
 - 4: by the 4th accel/decel time
 - 5: by auto accel/decel

📖 It is used to set the accel./decel. time selection when stall prevention occurs at constant speed.

↗ **06-06** Over-torque Detection Selection (OT1)

Factory Setting: 0

- Settings
- 0: Disable
 - 1: Over-torque detection during constant speed operation, continue to operate after detection
 - 2: Over-torque detection during constant speed operation, stop operation after detection
 - 3: Over-torque detection during operation, continue to operate after detection
 - 4: Over-torque detection during operation, stop operation after detection

↗ **06-09** Over-torque Detection Selection (OT2)

Factory Setting: 0

- Settings
- 0: Disable
 - 1: Over-torque detection during constant speed operation, continue to operate after detection
 - 2: Over-torque detection during constant speed operation, stop operation after detection
 - 3: Over-torque detection during operation, continue to operation after detection
 - 4: Over-torque detection during operation, stop operation after detection

📖 When Pr.06-06 and Pr.06-09 are set to 1 or 3, it will display a warning message and won't have an abnormal record.

📖 When Pr.06-06 and Pr.06-09 are set to 2 or 4, it will display a warning message and will have an abnormal record.

↗ **06-07** Over-torque Detection Level (OT1)

Factory Setting: 120

- Settings 10 to 250% (100%: drive's rated current)

↗ **06-08** Over-torque Detection Level (OT1)

Factory Setting: 0.1

- Settings 0.0~60.0 sec

06-10 Over-torque Detection Level (OT2)

Factory Setting: 120

Settings 10 to 250% (100%: drive's rated current)

06-11 Over-torque Detection Time (OT2)

Factory Setting: 0.1

Settings 0.0~60.0 sec

📖 Over torque detection is determine by the following method: if the output current exceeds the over-torque detection level (Pr.06-07, factory setting: 150%) and also exceeds Pr.06-08 Over-Torque Detection Time, the fault code "ot1/ot2" will appear. If a Multi-Functional Output Terminal is to over-torque detection (setting 7 or 8), the output is on. Please refer to Pr.02-13~02-14 for details.

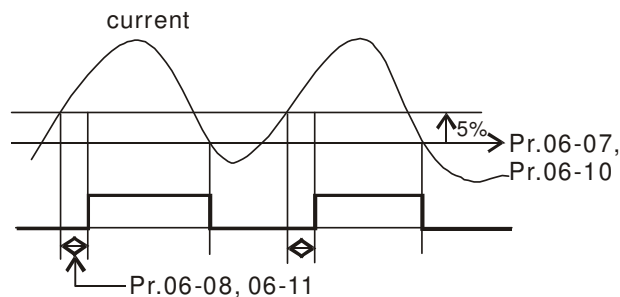

06-12 Current Limit

Factory Setting: 150

Settings 0~250% (100%: drive's rated current)

📖 Pr.06-12 sets the maximum output current of the drive. Pr.06-12 and Pr.11-17 ~ Pr.11-20 are used to set the drive's output current limit. When the drive is in VF, SVC or VFPG control mode, output frequency will decreases as the output current reaches current limit. It is a current stall prevention.

06-13 Electronic Thermal Relay Selection (Motor 1)

06-27 Electronic Thermal Relay Selection (Motor 2)

Factory Setting: 2

Settings 0: Inverter motor
1: Standard motor
2: Disable

📖 It is used to prevent self-cooled motor overheats under low speed. User can use electronic thermal relay to limit driver's output power.

06-14 Electronic Thermal Characteristic for Motor 1

06-28 Electronic Thermal Characteristic for Motor 2

Factory Setting: 60.0

Settings 30.0~600.0 sec

📖 The parameter is set by the 150% of motor rated current and the setting of Pr.06-14 and Pr.06-28 to prevent the motor damaged from overheating. When it reaches the setting, it will display

“EoL1/EoL2” and the motor will be in free running.

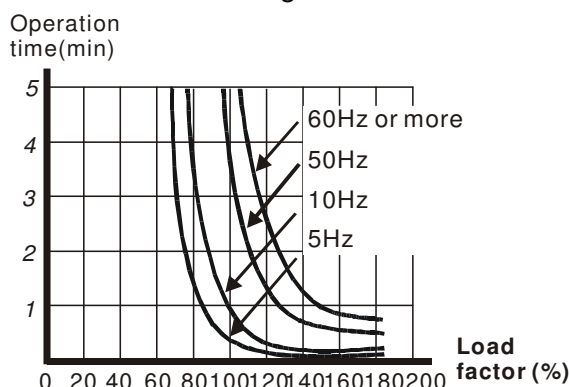

06-15 Heat Sink Over-heat (OH) Warning

Factory Setting: 100.0

Settings 0.0~110.0°C

Pr.06-15 sets the heat sink temperature level of the drive. The drive will output an overheating warning when the temperature exceeds the setting of Pr.06-15. If the setting of Pr.06-15 is higher than the default setting of the drive, the drive will use the default setting level for warning output. Capacitor (CAP) overheating level is set by the drive’s default setting, it can not be adjusted.

Over-heating Level (°C)			Over-heating Level (°C)		
Model	IGBT OH1	CAP OH 2	Model	IGBT OH1	CAP OH 2
VFD004CB21A-20	100	95	VFD022CB23A-20	100	95
VFD007CB21A-20	100	95	VFD037CB23A-20	100	95
VFD004CB23A-20	100	95	VFD022CB43A-20	100	95
VFD007CB23A-20	100	95	VFD037CB43A-20	100	100
VFD007CB43A-20	100	95	VFD015CB21A-21M	100	95
VFD015CB43A-20	100	95	VFD022CB21A-21M	100	95
VFD015CB23A-20	100	95	VFD022CB23A-21M	100	95
VFD004CB21A-21M	100	95	VFD037CB23A-21M	100	95
VFD007CB21A-21M	100	95	VFD022CB43A-21M	100	95
VFD007CB23A-21M	100	95	VFD037CB43A-21M	100	100
VFD004CB43A-21M	100	95	VFD040CB43A-20	100	90
VFD007CB43A-21M	100	95	VFD055CB43A-20	100	90
VFD015CB43A-21M	100	95	VFD075CB43A-20	100	110
VFD015CB23A-21M	100	95	VFD040CB43A-21M	100	90
VFD015CB21A-20	100	95	VFD055CB43A-21M	100	90
VFD022CB21A-20	100	95	VFD075CB43A-21M	100	110

06-16 Stall Prevention Limit Level

Factory Setting: 50

Settings 0~100% (Refer to Pr.06-03, Pr.06-04)

When operation frequency is larger than Pr.01-01; e.g. Pr06-03=150%, Pr. 06-04=100% and Pr. 06-16=80%:

Calculate the Stall Prevention Level during acceleration: Pr.06-03 * Pr.06-16=150x80%=120%.

Calculate the Stall Prevention Level at constant speed: Pr.06-04 * Pr.06-16=100x80%=80%.

06-17 Present Fault Record

06-18 Second Most Recent Fault Record

06-19	Third Most Recent Fault Record
06-20	Fourth Most Recent Fault Record
06-21	Fifth Most Recent Fault Record
06-22	Sixth Most Recent Fault Record

Factory Setting: 0

Settings 0~107

- 📖 The details of fault codes refer to Pr.06-23~06-26.
- 📖 When the fault occurs and force stopping, it will record in this parameter.
- 📖 At stop with low voltage Lv (LvS warn, no record). During operation with mid-low voltage Lv (LvA, Lvd, Lvn error, will record).
- 📖 Setting 62: when dEb function is enabled, the drive will execute dEb and record to the Pr.06-17 to Pr.06-22 simultaneously.

06-23	Fault Output Option 1
06-24	Fault Output Option 2
06-25	Fault Output Option 3
06-26	Fault Output Option 4

Factory Setting: 0

Settings 0 to 65535 sec (refer to bit table for fault code)

- 📖 These parameters can be used with multi-function output (set to 35-38) for the specific requirement. When the fault occurs, the corresponding terminals will be activated (It needs to convert binary value to decimal value to fill in Pr.06-23 to Pr.06-26).

Fault Code	bit0	bit1	bit2	bit3	bit4	bit5	bit6
	current	Volt.	OL	SYS	FBK	EXI	CE
0: No fault							
1: Over-current during acceleration (ocA)	●						
2: Over-current during deceleration (ocd)	●						
3: Over-current during constant speed (ocn)	●						
4: Ground fault (GFF)	●						
5: IGBT short-circuit (occ)	●						
6: Over-current at stop (ocS)	●						
7: Over-voltage during acceleration (ovA)		●					
8: Over-voltage during deceleration (ovd)		●					
9: Over-voltage during constant speed (ovn)		●					
10: Over-voltage at stop (ovS)		●					
11: Low-voltage during acceleration (LvA)		●					
12: Low-voltage during deceleration (Lvd)		●					
13: Low-voltage during constant speed (Lvn)		●					
14: Stop mid-low voltage (LvS)		●					
15: Phase loss protection (PHL)		●					
16: IGBT over-heat (oH1)			●				

Fault Code	bit0	bit1	bit2	bit3	bit4	bit5	bit6
	current	Volt.	OL	SYS	FBK	EXI	CE
17: Capacitance over-heat (oH2)			●				
18: tH1o (TH1 open)			●				
19: tH2o (TH2 open)			●				
20: Reserved							
21: Drive over-load (oL)			●				
22: Electronics thermal relay 1 (EoL1)			●				
23: Electronics thermal relay 2 (EoL2)			●				
24: Motor PTC overheat (oH3) (PTC)			●				
25: Reserved							
26: Over-torque 1 (ot1)			●				
27: Over-torque 2 (ot2)			●				
28: Low current (uC)	●						
29: Reserved							
30: Memory write-in error (cF1)				●			
31: Memory read-out error (cF2)				●			
32: Reserved							
33: U-phase current detection error (cd1)				●			
34: V-phase current detection error (cd2)				●			
35: W-phase current detection error (cd3)				●			
36: Clamp current detection error (Hd0)				●			
37: Over-current detection error (Hd1)				●			
38: Over-voltage detection error (Hd2)				●			
39: occ IGBT short circuit detection error (Hd3)				●			
40: Auto tuning error (AUE)				●			
41: PID feedback loss (AFE)					●		
42: PG feedback error (PGF1)					●		
43: PG feedback loss (PGF2)					●		
44: PG feedback stall (PGF3)					●		
45: PG slip error (PGF4)					●		
46: Reserved							
47: Reserved							
48: Analog current input loss (ACE)					●		
49: External fault input (EF)						●	
50: Emergency stop (EF1)						●	
51: External Base Block (bb)						●	
52: Password error (Pcod)				●			
53: Reserved							

Fault Code	bit0	bit1	bit2	bit3	bit4	bit5	bit6
	current	Volt.	OL	SYS	FBK	EXI	CE
54: Communication error (CE1)							●
55: Communication error (CE2)							●
56: Communication error (CE3)							●
57: Communication error (CE4)							●
58: Communication Time-out (CE10)							●
59: Reserved							
60: Brake transistor error (bF)						●	
61: Y-connection/ Δ -connection switch error (ydc)						●	
62: Decel. Energy Backup Error (dEb)		●					
63: Slip error (oSL)						●	
64: Electromagnet switch error (ryF)						●	
65: PG Card Error (PG)						●	
66~78: Reserved							
79: U phase output phase loss (Uoc)	●						
80: V phase output phase loss (Voc)	●						
81: W phase output phase loss (Woc)	●						
82: U phase output phase loss (OPHL)	●						
83: V phase output phase loss (OPHL)	●						
84: W phase output phase loss (OPHL)	●						
85~100: Reserved							
101: CANopen software disconnect 1 (CGdE)							●
102: CANopen software disconnect 2 (CHbE)							●
103: CANopen synchronous error (CSYE)							●
104: CANopen hardware disconnect (CbFE)							●
105: CANopen index setting error (CIdE)							●
106: CANopen slave station number setting error (CAdE)							●
107: CANopen index setting exceed limit (CFrE)							●

06-29 PTC (Positive Temperature Coefficient) Detection Selection

Factory Setting: 0

- Settings
- 0: Warn and keep operating
 - 1: Warn and ramp to stop
 - 2: Warn and coast to stop
 - 3: No warning

 Pr.06-29 setting defines how the will drive operate after PTC detection.

06-30 PTC Level

Factory Setting: 50.0

Settings 0.0~100.0%

It needs to set AVI/ACI/AUI analog input function Pr.03-00~03-02 to 6 (P.T.C. thermistor input value).

It is used to set the PTC level, and the corresponding value for 100% is max. analog input value.

06-31 Frequency Command for Malfunction

Factory Setting: Read only

Settings 0.00~655.35Hz

When malfunction occurs, user can check the frequency command. If it happens again, it will overwrite the previous record.

06-32 Output Frequency at Malfunction

Factory Setting: Read only

Settings 0.00~655.35Hz

When malfunction occurs, user can check the current frequency command. If it happens again, it will overwrite the previous record.

06-33 Output Voltage at Malfunction

Factory Setting: Read only

Settings 0.0~6553.5V

When malfunction occurs, user can check current output voltage. If it happens again, it will overwrite the previous record.

06-34 DC Voltage at Malfunction

Factory Setting: Read only

Settings 0.0~6553.5V

When malfunction occurs, user can check the current DC voltage. If it happens again, it will overwrite the previous record.

06-35 Output Current at Malfunction

Factory Setting: Read only

Settings 0.00~655.35Amp

When malfunction occurs, user can check the current output current. If it happens again, it will overwrite the previous record.

06-36 IGBT Temperature at Malfunction

Factory Setting: Read only

Settings 0.0~6553.5°C

When malfunction occurs, user can check the current IGBT temperature. If it happens again, it will overwrite the previous record.

06-37 Capacitance Temperature at Malfunction

Factory Setting: Read only

Settings 0.0~6553.5°C

When malfunction occurs, user can check the current capacitance temperature. If it happens again, it will overwrite the previous record.

06-38 Motor Speed in rpm at Malfunction

Factory Setting: Read only

Settings 0.0~6553.5°C

When malfunction occurs, user can check the current motor speed in rpm. If it happens again, it will overwrite the previous record.

06-39 Torque Command at Malfunction

Factory Setting: Read only

Settings 0~65535

When malfunction occurs, user can check the current torque command. If it happens again, it will overwrite the previous record.

06-40 Status of Multi-function Input Terminal at Malfunction

Factory Setting: Read only

Settings 0000h~FFFFh

06-41 Status of Multi-function Output Terminal at Malfunction

Factory Setting: Read only

Settings 0000h~FFFFh

When malfunction occurs, user can check the status of multi-function input/output terminals. If it happens again, it will overwrite the previous record.

06-42 Drive Status at Malfunction

Factory Setting: Read only

Settings 0000H~FFFFh

When malfunction occurs, please check the drive status (communication address 2101H). If malfunction happens again, the previous record will be overwritten by this parameter.

06-43 Reserved**06-44** Reserved

↗ **06-45** Treatment to Output Phase Loss Detection (OPHL)

Factory Setting: 3

Settings

- 0: Warn and keep operating
- 1: Warn and ramp to stop
- 2: Warn and coast to stop
- 3: No warning

Pr.06-45 defines how the drive will operate when output phase loss occur.

↗	06-46	Deceleration Time of Output Phase Loss	Factory Setting:0.500
		Settings 0.000~65.535 sec	
↗	06-47	Current Bandwidth	Factory Setting:1.00
		Settings 0.00~100.00%	
↗	06-48	DC Brake Time of Output Phase Loss	Factory Setting:0.000
		Settings 0.000~65.535 sec	
	06-49	Reserved	
	06-51	Reserved	
↗	06-50	Time for Input Phase Loss Detection	Factory Setting:0.20
		Settings 0.00~600.00 sec	
↗	06-52	Ripple of Input Phase Loss	Factory Setting:30.0 / 60.0
		Settings 230V Series: 0.0~160.0 Vdc 460V Series: 0.0~320.0 Vdc	
↗	06-53	Treatment for the detected Input Phase Loss (OrP)	Factory Setting: 0
		Settings 0: warn, ramp to stop 1: warn, coast to stop	

📖 When voltage of DC side is detected that ripple is higher than Pr.06-52's setting, it continues as Pr.06-50 sets and plus more 30 seconds, the drive will execute input phase loss protection according to Pr.06-63's setting.

📖 Ripple decreases to be lower than Pr.06-52's setting within the time of Pr.06-50 setting and plus more 30 seconds, and then the function OrP will restart.

	06-54	Reserved	
--	--------------	----------	--

↗	06-55	Derating Protection	Factory Setting: 0
		Settings 0: constant rated current and limit carrier wave by load current and temperature 1: constant carrier frequency and limit load current by setting carrier wave 2: constant rated current(same as setting 0), but close current limit	

📖 Setting 0:

When the rated current is constant, carrier frequency (Fc) outputted by PWM will auto decrease according to surrounding temperature, overload output current and time. If overload situation is not frequent and only cares the carrier frequency operated with the rated current for a long time and carrier wave changes during short overload, it is recommended to set to 0.

Refer to the following diagram for the level of carrier frequency. Take VFD007CB43A-20 in normal duty as example, surrounding temperature 50°C with independent installation and UL open-type. When the carrier frequency is set to 15kHz, it corresponds to 72% rated output current. When it outputs higher than the value, it will auto decrease the carrier frequency. If the output is 83% rated current and the carrier frequency will decrease to 12kHz. In addition, it will also decrease the carrier frequency when overload. When the carrier frequency is 15kHz and the current is $120\% \times 72\% = 86\%$ for a minute, the carrier frequency will decrease to the factory setting.

Setting 1:

It is used for the fixed carrier frequency and prevents the carrier wave changes and motor noise caused by the surrounding temperature and frequent overload.

Refer to the following for the derating level of rated current. Take VFD007CB43A-20 in normal duty as example, when the carrier frequency keeps in 15kHz and the rated current is decreased to 72%, it will have OL protection when the current is $120\% \times 72\% = 86\%$ for a minute. Therefore, it needs to operate by the curve to keep the carrier frequency.

Setting 2:

It sets the protection method and action to 0 and disables the current limit for the Ratio*160% of output current in the normal duty and Ratio*180% of output current in the heavy duty. The advantage is that it can provide higher output current when the setting is higher than the factory setting of carrier frequency. The disadvantage is that it decreases carrier wave easily when overload.

Derating curve diagram in the heavy duty (Pr.00-16=1)

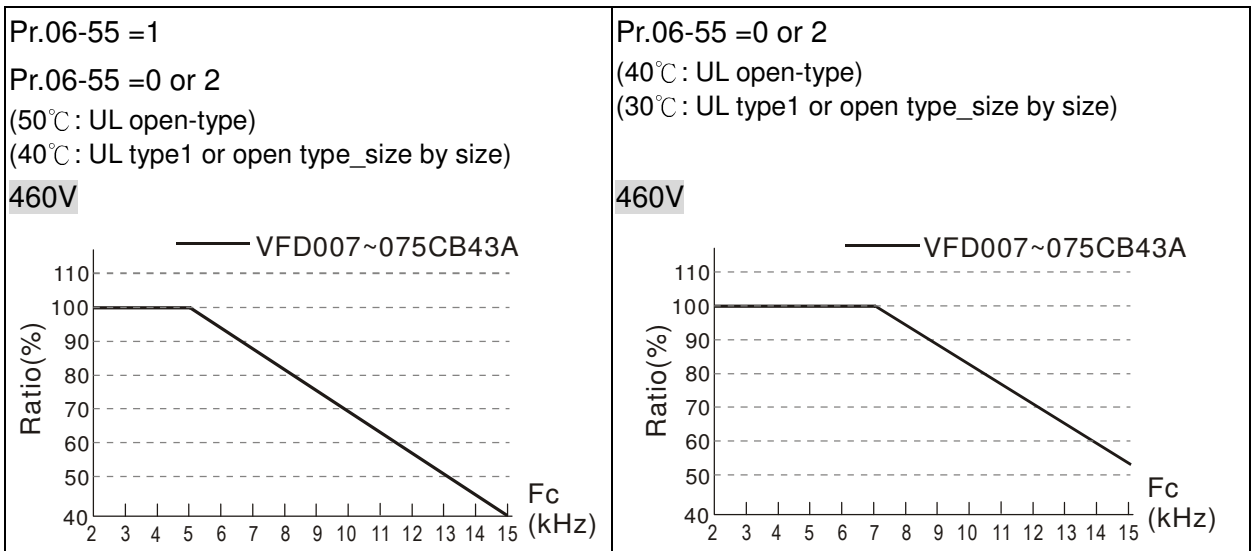

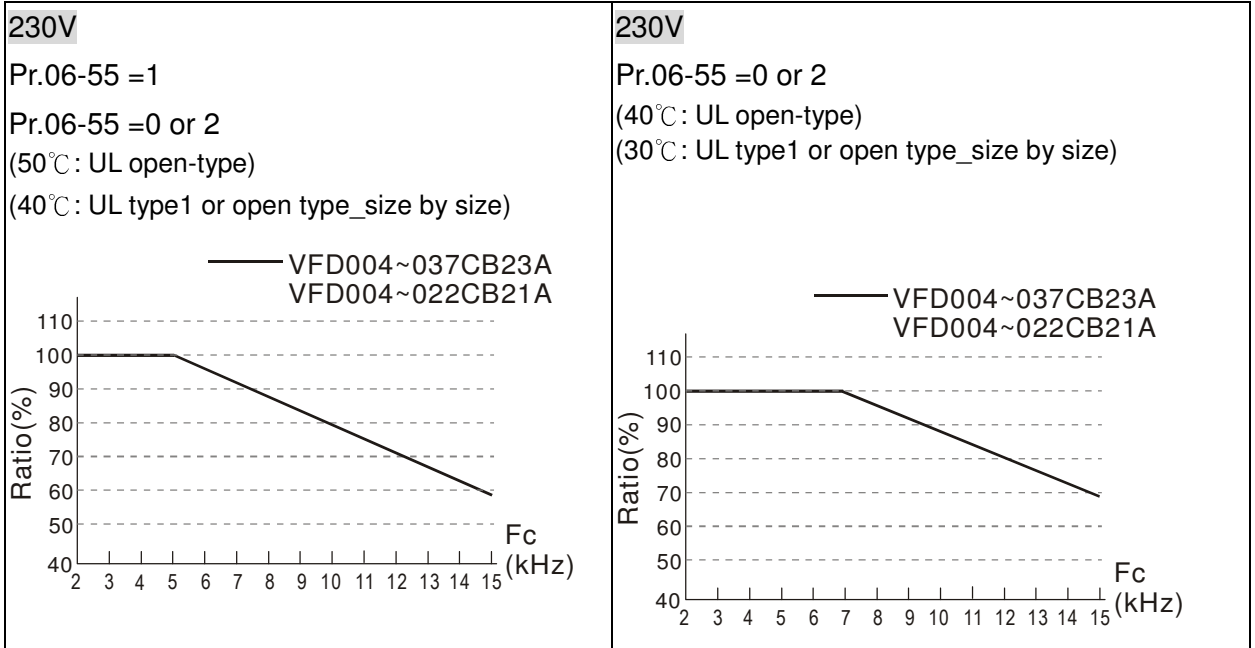

Derating curve diagram in the normal duty (Pr.00-16=0)

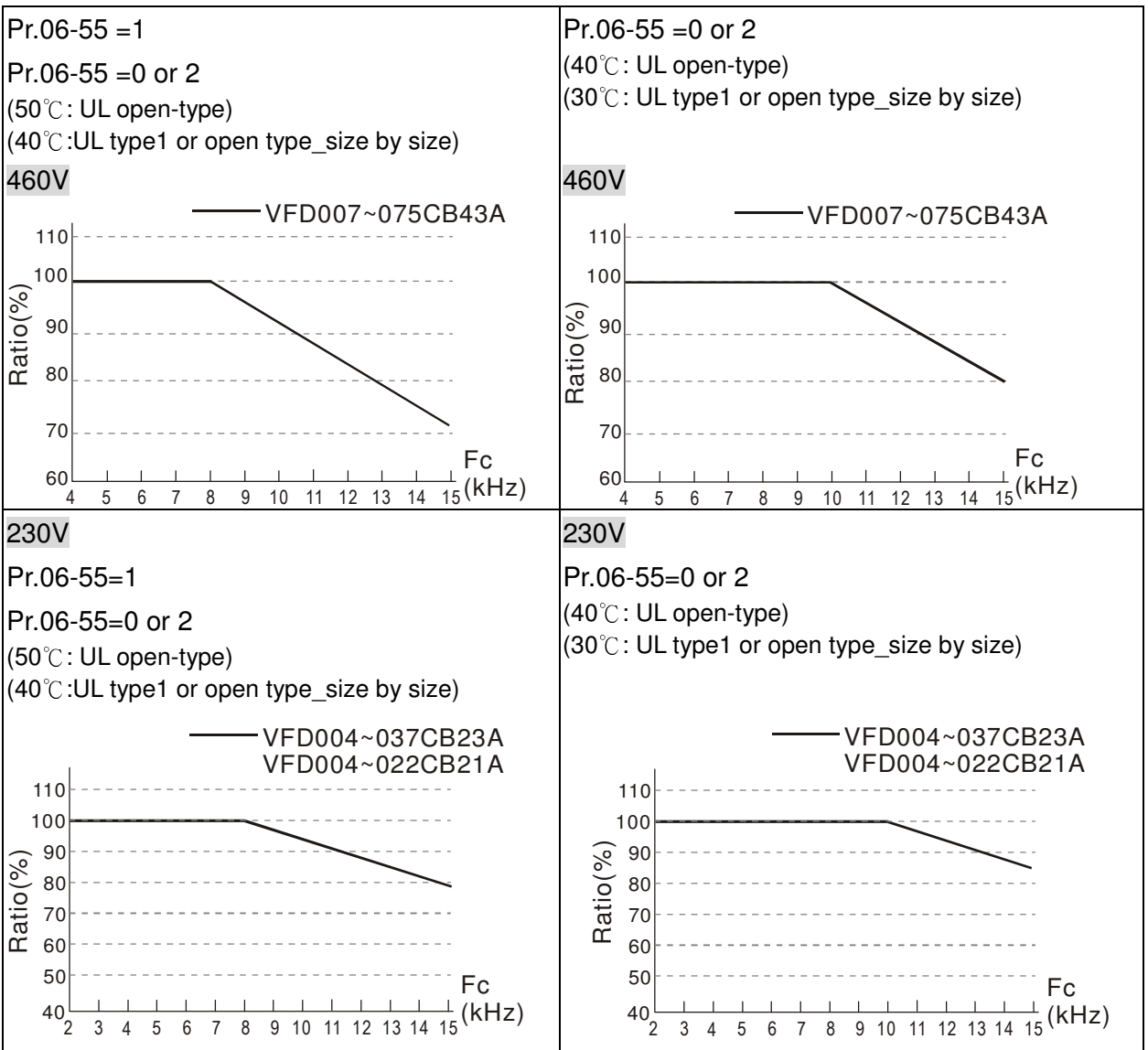

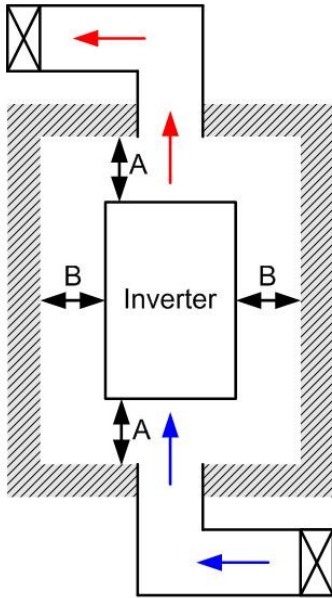

NOTE

- ※ The mounting clearances stated in the figure is for installing the drive in an open area. To install the drive in a confined space (such as cabinet or electric box), please follow the following three rules: (1) Keep the minimum mounting clearances. (2) Install a ventilation equipment or an air conditioner to keep surrounding temperature lower than operation temperature. (3) Refer to parameter setting and set up Pr. 00-16, Pr.00-17, and Pr. 06-55.
- ※ The following table shows heat dissipation and the required air volume when installing a single drive in a confined space. When installing multiple drives, the required air volume shall be multiplied by the number the drives.
- ※ Refer to the chart (Air flow rate for cooling) for ventilation equipment design and selection.
- ※ Refer to the chart (Power dissipation) for air conditioner design and selection.

Minimum mounting clearances:

Frame	A (mm)	B (mm)	C (mm)	D (mm)
A0~A	60	30	10	0

Model No.	Air flow rate for cooling		Power Dissipation		
	Flow Rate (cfm)	Flow Rate (m ³ /hr)	Loss External (Heat sink)	Internal	Total
VFD004CB21A-20/-21/-21M	-	-	16	20	36
VFD007CB21A-20/-21/-21M	-	-	32	39	72
VFD015CB21A-20/-21/-21M	15	26	60	52	112
VFD022CB21A-20/-21/-21M	15	26	85	69	154
VFD004CB23A-20/-21/-21M	-	-	21	17	37
VFD007CB23A-20/-21/-21M	-	-	35	26	61
VFD015CB23A-20/-21/-21M	15	26	56	32	89
VFD022CB23A-20/-21/-21M	15	26	82	34	116
VFD037CB23A-20/-21/-21M	15	26	118	43	161
VFD007CB43A-20/-21/-21M	-	-	35	24	59
VFD015CB43A-20/-21/-21M	-	-	47	27	74
VFD022CB43A-20/-21/-21M	15	26	75	30	105
VFD037CB43A-20/-21/-21M	15	26	110	33	143
VFD040CB43A-20/-21/-21M	15	26	126	34	160
VFD055CB43A-20/-21/-21M	15	26	145	37	181
VFD075CB43A-20/-21/-21M	24	41	212	83	295
VFD022CB43B-20	49	83	75	33	108
VFD037CB43B-20	49	83	110	36	146
VFD040CB43B-20	46	78	126	37	163
VFD055CB43B-20	46	78	145	40	185
VFD075CB43B-20	46	78	212	84	296
	※ The required airflow shown in chart is for installing one drive in confined space. ※ When installing the multiple drives, the required air volume should be the required air volume for single drive X the number of the drives.		※ The heat dissipation shown in the chart is for installing single drive in a confined space. ※ When installing multiple drives, volume of heat dissipation should be the heat dissipated for single drive X the number of the drives. ※ Heat dissipation for each model is calculated by rated voltage, current and default carrier.		

06-56

~ Reserved

06-59

↗ **06-60** Software Detection GFF Current Level

Factory Setting: 60.0

Settings 0.0~6553.5 %

↗ **06-61** Software Detection GFF Filter Time

Factory Setting: 0.10

Settings 0.0~6553.5 %

06-62 Disable Level of dab

Factory Setting: 180.0/360.0

Settings 230V series: 0.0~220.0 Vdc
460V series: 0.0~440.0 Vdc

06-63 Fault Record 1 (Days)

06-65 Fault Record 2 (Days)

06-67 Fault Record 3 (Days)

06-69 Fault Record 4 (Days)

Factory Setting: Read only

Settings 0~65535 days

06-64 Fault Record 1 (Min.)

06-66 Fault Record 2 (Min.)

06-68 Fault Record 3 (Min.)

06-70 Fault Record 4 (Min.)

Factory Setting: Read only

Settings 0~1439 min.

📖 When there is any malfunctions in motor drive operation, Pr.06-17~06-22 will record malfunctions, and Pr.06-63~06-70 can record the operation time for 4 malfunctions in sequence. It can help to check if there is any wrong with the drive according to the recorded internal time.

For example: The 1st fault, ocA, occurs in 1000 minutes after motor drive starts operation. The 2nd fault, ocd, happens after another 1000 minutes. The 3rd fault, ocA, happens after another 1000 minutes. Then, the 5th fault, ocd, happens after 1000 minutes by following 4th fault. Last, the 6th fault, ocn, happens after 1000 minutes of the 5th fault. It will be recorded as the following table:

	1 st Error	2 nd Error	3 rd Error	4 th Error	5 th Error	6 th Error
06-17	ocA	ocd	ocn	ocA	ocd	ocn
06-18	0	ocA	ocd	ocn	ocA	ocd
06-19	0	0	ocA	ocd	ocn	ocA
06-20	0	0	0	ocA	ocd	ocn

	1 st Error	2 nd Error	3 rd Error	4 th Error	5 th Error	6 th Error
06-21	0	0	0	0	ocA	ocd
06-22	0	0	0	0	0	ocA
06-63	0	1	2	2	3	4
06-64	1000	560	120	1120	680	240
06-65	0	0	1	2	2	3
06-66	0	1000	560	120	1120	680
06-67	0	0	0	1	2	3
06-68	0	0	1000	560	120	1120
06-69	0	0	0	0	1	2
06-70	0	0	0	1000	560	120

※ As the table shows, it can be known that the last fault (Pr.06-17) happened after the drive runs for 4 days and 240 minutes.

↗ **06-71** Low Current Setting Level

Factory Setting: 0.0

Settings 0.0 ~ 6553.5 %

↗ **06-72** Low Current Detection Time

Factory Setting: 0.00

Settings 0.00 ~ 655.35 sec

↗ **06-73** Treatment for low current

Factory Setting: 0

Settings 0 : No function
 1 : warn and coast to stop
 2 : warn and ramp to stop by 2nd deceleration time
 3 : warn and operation continue

07 Special Parameters

✎ This parameter can be set during operation.

✎ 07-00 Software Brake Level

Factory Setting: 380.0/760.0

Settings 230V series: 350.0~450.0Vdc
460V series: 700.0~900.0Vdc

📖 This parameter sets the DC-bus voltage at which the brake chopper is activated. Users can choose the suitable brake resistor to have the best deceleration. Refer to Chapter 7 Accessories for the information of the brake resistor.

📖 It is only valid for the models below 30kW of 460 series and 22kW of 230 series.

✎ 07-01 DC Brake Current Level

Factory Setting: 0

Settings 0~100%

📖 This parameter sets the level of DC Brake Current output to the motor during start-up and stopping. When setting DC Brake Current, the Rated Current is regarded as 100%. It is recommended to start with a low DC Brake Current Level and then increase until proper holding torque has been attained.

📖 When it is in FOC PG/TQCPG mode, DC brake is zero-speed operation. It can enable DC brake function by setting to any value.

✎ 07-02 DC Brake Time at Start-up

Factory Setting: 0.0

Settings 0.0~60.0 sec

📖 The motor may be in the rotation status due to external force or itself inertia. If the drive is used with the motor at this moment, it may cause motor damage or drive protection due to over current. This parameter can be used to output DC current before motor operation to stop the motor and get a stable start. This parameter determines the duration of the DC Brake current after a RUN command. When it is set to 0.0, it is invalid.

✎ 07-03 DC Brake Time at Stop

Factory Setting: 0.00

Settings 0.0~60.00 sec

📖 The motor may be in the rotation status after drive stop outputting due to external force or itself inertia and can't stop accurately. This parameter can output DC current to force the motor drive stop after drive stops to make sure that the motor is stop.

📖 This parameter determines the duration of the DC Brake current during stopping. To DC brake at stop, this function will be valid when Pr.00-22 is set to 0 or 2. When setting to 0.0, it is invalid.

📖 Related parameters: Pr.00-22 Stop Method, Pr.07-04 Start-point for DC Brake





✎ 07-04 Start-Point for DC Brake

Factory Setting: 0.00

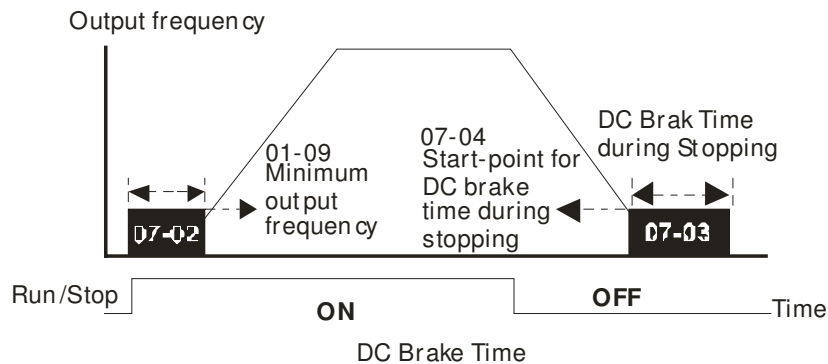
Settings 0.00~600.00Hz

-  This parameter determines the frequency when DC Brake will begin during deceleration. When this setting is less than start frequency (Pr.01-09), the start-point for DC brake will start from the min. frequency.



-  DC Brake at Start-up is used for loads that may move before the AC drive starts, such as fans and pumps. Under such circumstances, DC Brake can be used to hold the load in position before setting it in motion.
-  DC Brake at stop is used to shorten the stopping time and also to hold a stopped load in position, such as crane or cutting machine.
-  DC Brake at Start-up is used for loads that may move before the AC drive starts, such as fans and pumps. Under such circumstances, DC Brake can be used to hold the load in position before setting it in motion.
-  DC Brake at stop is used to shorten the stopping time and also to hold a stopped load in position, such as crane or cutting machine.

07-05 Reserved





07-06 Restart after Momentary Power Loss

Factory Setting: 0

Settings 0: Stop operation

1: Speed search for last frequency command

2: Speed search for the minimum output frequency

-  This parameter determines the operation mode when the AC motor drive restarts from a momentary power loss.
-  The power connected to the drive may power off momentarily due to many reasons. This function allows the drive to keep outputting after power is on again after power off and won't cause drive stops.
-  Setting 1: Operation continues after momentary power loss, speed search starts with the Master Frequency reference value after drive output frequency and motor rotator speed is synchronous. The motor has the characteristics of big inertia and small obstruction. For example, in the equipment with big inertia wheel, it doesn't need to wait to execute operation command until wheel is complete stop after re-start to save time.
-  Setting 2: Operation continues after momentary power loss, speed search starts with the master frequency after drive output frequency and motor rotator speed is synchronous. The motor has the characteristics of small inertia and bigger obstruction.

In PG control mode, the AC motor drive will execute the speed search function automatically by the PG speed when this setting isn't set to 0.

07-07 Maximum Power Loss Duration

Factory Setting: 2.0

Settings 0.1~20.0 sec

If the duration of a power loss is less than this parameter setting, the AC motor drive will resume operation. If it exceeds the Maximum Allowable Power Loss Time, the AC motor drive output is then turned off (coast stop).

The selected operation after power loss in Pr.07-06 is only executed when the maximum allowable power loss time is ≤ 5 seconds and the AC motor drive displays "LU".

But if the AC motor drive is powered off due to overload, even if the maximum allowable power loss time is ≤ 5 seconds, the operation mode as set in Pr.07-06 is not executed. In that case it starts up normally.

07-08 Base block Time

Factory Setting: 0.5

Settings 0.1~5.0 sec

When momentary power loss is detected, the AC drive will block its output and then wait for a specified period of time (determined by Pr.07-08, called Base-Block Time) before resuming operation. This parameter should be set at a value to ensure that any residual regeneration voltage from the motor on the output has disappeared before the drive is activated again.

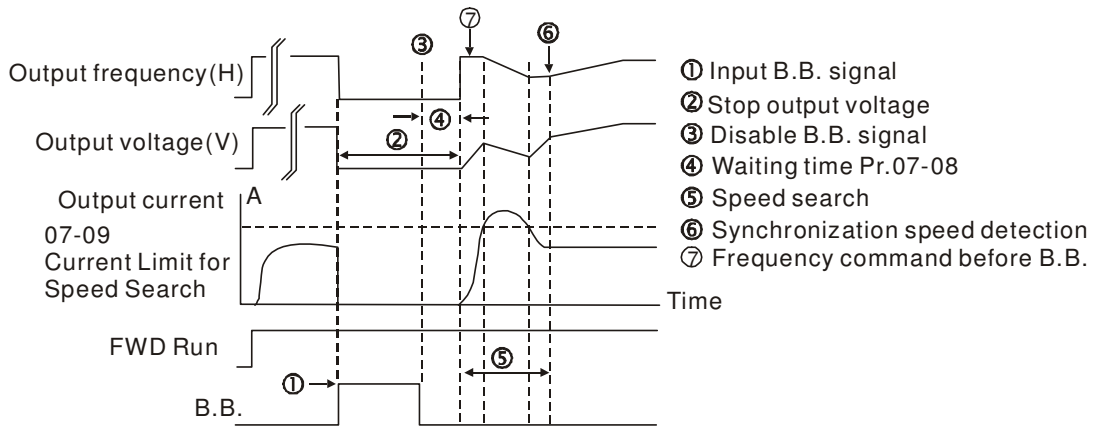

B.B. Search with last output frequency downward timing chart

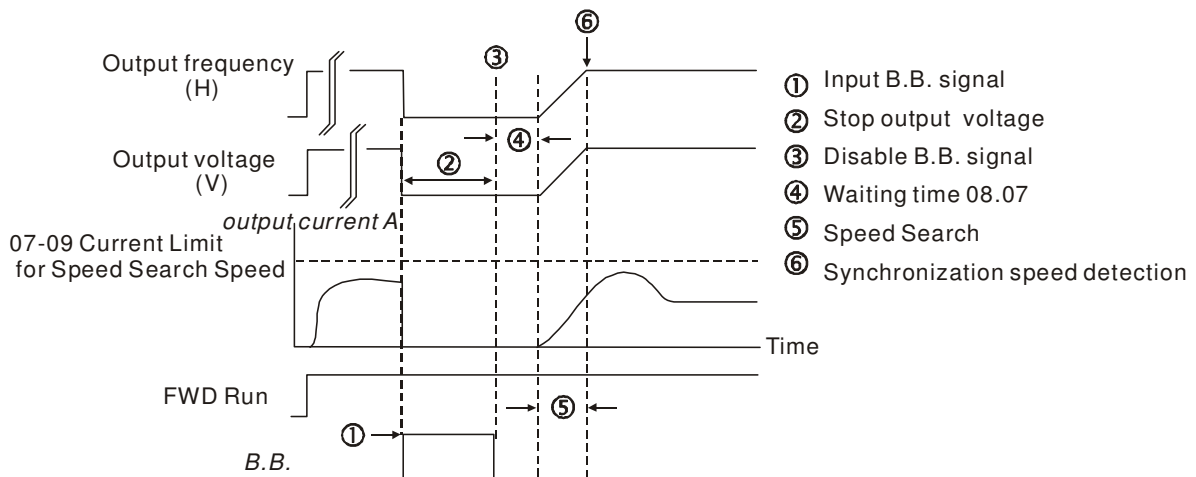

B.B. Search with minimum output frequency upward timing chart

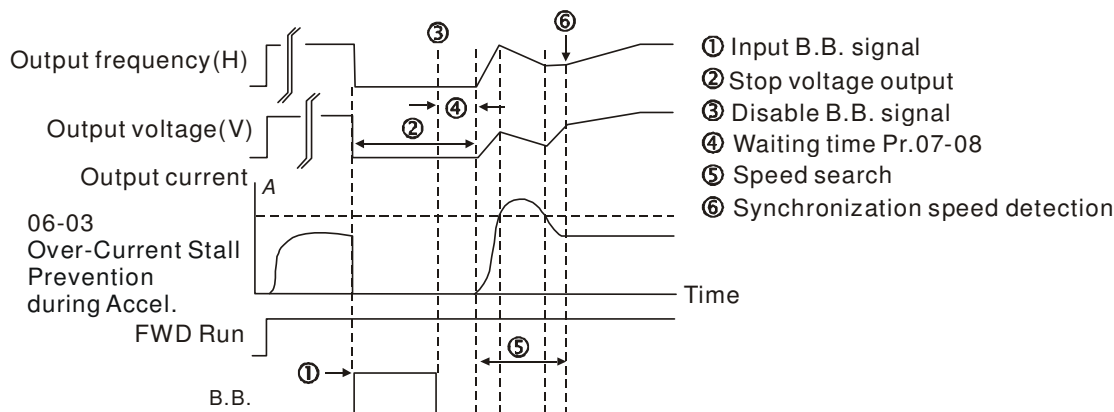

B.B. Search with minimum output frequency upward timing chart

07-09 Current Limit for Speed Search

Factory Setting: 50

Settings 20~200%

- 📖 Following a momentary power loss, the AC motor drive will start its speed search operation only if the output current is greater than the value set by Pr.07-09.
- 📖 When executing speed search, the V/f curve is operated by group 1 setting. The maximum current for the optimum accel./decel. and start speed search is set by Pr.07-09.
- 📖 The speed search level will affect the synchronous time. It will get the synchronization faster when this parameter is set to larger value. But too large value may active overload protection.

07-10 Treatment to Reboots After Fault

Factory Setting: 0

Settings 0: Stop operation

1: Speed search starts with current speed

2: Speed search starts with minimum output frequency

- 📖 In PG control mode, the AC motor drive will execute the speed search function automatically by the PG speed when this setting isn't set to 0.
- 📖 Fault includes: bb, oc, ov, occ etc. To restart after oc, ov, occ, Pr.07-11 can not be set to 0.

07-11 Auto Restart After Fault

Factory Setting: 0

Settings 0~10

- 📖 After fault (oc, ov, ov), occurs the AC motor drive can be reset/restarted automatically up to 10 times.
- 📖 Setting this parameter to 0 will disable the reset/restart operation after any fault has occurred. When enabled, the AC motor drive will restart with speed search, which starts at the frequency before the fault.
- 📖 If the drive execute reset/restart after fault more than the numbers of time set in Pr.07-11 and the limit is reached within the time period in Pr.07-33, the drive will stop execute reset/restart after fault function. User will be need to input RESET manually for the drive to continue operation.

07-12 Speed Search during Start-up

Factory Setting: 0

- Settings
- 0: Disable
 - 1: Speed search from maximum output frequency
 - 2: Speed search from start-up motor frequency
 - 3: Speed search from minimum output frequency
-

 This parameter is used for starting and stopping a motor with a high inertia. A motor with high inertia will take 2-5 minutes or longer to stop completely. By setting this parameter, the user does not need to wait for the motor to come to a complete stop before restarting the AC motor drive. If a PG card and encoder is used on the drive and motor, then the speed search will start from the speed that is detected by the encoder and accelerate quickly to the commanded frequency. The output current is set by the Pr.07-09.

 In PG control mode, the AC motor drive will execute the speed search function automatically by the PG speed when this setting isn't set to 0.

07-13 Decel. Time at Momentary Power Loss (dEb function)

Factory Setting: 0

- Settings
- 0: Disable
 - 1: 1st decel. time
 - 2: 2nd decel. time
 - 3: 3rd decel. time
 - 4: 4th decel. time
 - 5: Current decel. time
 - 6: Auto decel. time
-

 This parameter is used for the decel. time selection for momentary power loss.

07-14 dEb Return Time

Factory Setting: 0.0

- Settings 0.0~25.0 sec
-

 function is the AC motor drive decelerates to stop after momentary power loss. When the momentary power loss occurs, this function can be used for the motor to decelerate to 0 speed with deceleration stop method. When the power is on again, motor will run again after DEB return time. (has applied on high-speed spindle)

Status 1: Insufficient power supply due to momentary power-loss/unstable power (due to low voltage)/sudden heavy-load.

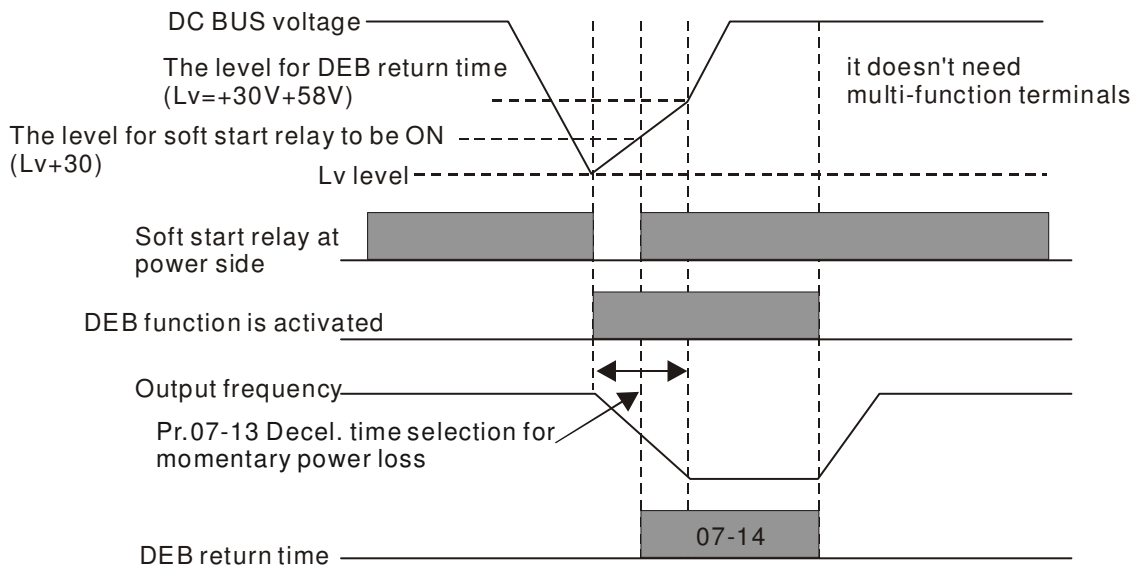

NOTE

When Pr.07-14 is set to 0, the AC motor drive will be stopped and won't re-start at the power-on again.

Status 2: unexpected power off, such as momentary power loss.

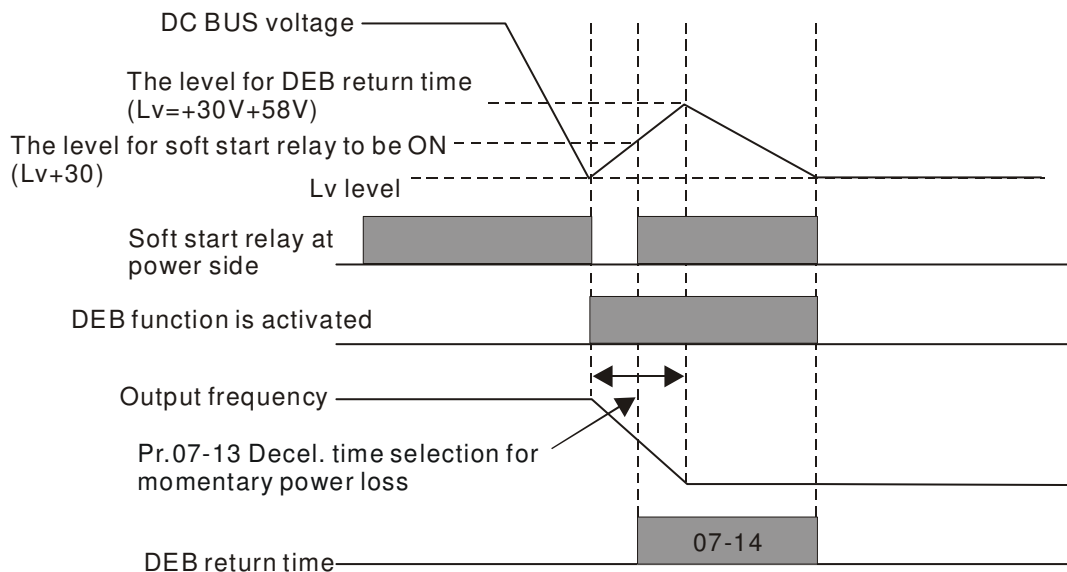

NOTE

For example, in textile machinery, you will hope that all the machines can be decelerated to stop to prevent broken stitching when power loss. In this case, the host controller will send a message to the AC motor drive to use dEb function with deceleration time via EF.

↙	07-15 Dwell Time at Accel.	Factory Setting: 0.00
	Settings 0.00~600.00 sec	
↙	07-16 Dwell Frequency at Accel.	Factory Setting: 0.00
	Settings 0.00~600.00Hz	

➤ **07-17** Dwell Time at Decel.

Factory Setting: 0.00

Settings 0.00~600.00 sec

➤ **07-18** Dwell Frequency at Decel.

Factory Setting: 0.00

Settings 0.00~600.00 Hz

📖 In the heavy load situation, Dwell can make stable output frequency temporarily, such as crane or elevator.

📖 Pr.07-15 to Pr.07-18 is for heavy load to prevent OV or OC occurs.

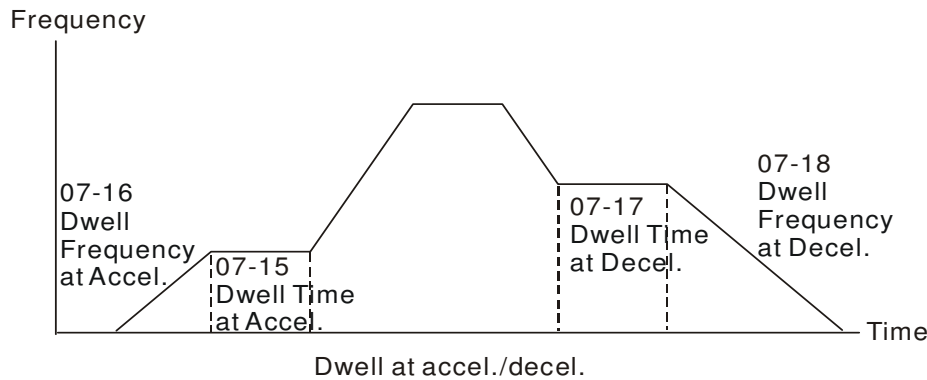

➤ **07-19** Fan Cooling Control

Factory Setting: 0

Settings 0: Fan always ON

1: 1 minute after the AC motor drive stops, fan will be OFF

2: When the AC motor drive runs, the fan is ON. When the AC motor drive stops, the fan is OFF

3: Fan turns ON when preliminary heat sink temperature (around 60°C) is attained.

4: Fan always OFF

📖 This parameter is used for the fan control.

📖 Setting 0: Fan will be ON as the drive's power is turned ON.

📖 Setting 1: 1 minute after AC motor drive stops, fan will be OFF

📖 Setting 2: AC motor drive runs and fan will be ON. AC motor drive stops and fan will be OFF.

📖 Setting 3: Fan run according to IGBT and capacitance temperature. Fan will be ON when preliminary capacitance temperature is higher than 60oC. Fan will be OFF, when capacitance temperature is lower than 40oC.

📖 Setting 4: Fan is always OFF

➤ **07-20** Emergency Stop (EF) & Force Stop

Factory Setting: 0

Settings 0: Coast to stop

1: Stop by 1st deceleration time

2: Stop by 2nd deceleration time

3: Stop by 3rd deceleration time

4: Stop by 4th deceleration time

5: System Deceleration

6: Automatic Deceleration

 Pr.07-20 determines AC motor drive stop method. When the multi-function input terminal is set to 10 or 18 and is activated, the drive will stop according to the setting in Pr.07-20.

07-21 Auto Energy-saving Operation

Factory Setting: 0

Settings 0: Disable

1: Enable

 When Pr.07-21 is set to 1, the acceleration and deceleration will operate with full voltage. During constant speed operation, it will auto calculate the best voltage value by the load power for the load. This function is not suitable for the ever-changing load or near full-load during operation.

 When the output frequency is constant, i.e. constant operation, the output voltage will auto decrease by the load reduction. Therefore, the drive will operate with min. power, multiplication of voltage and current.

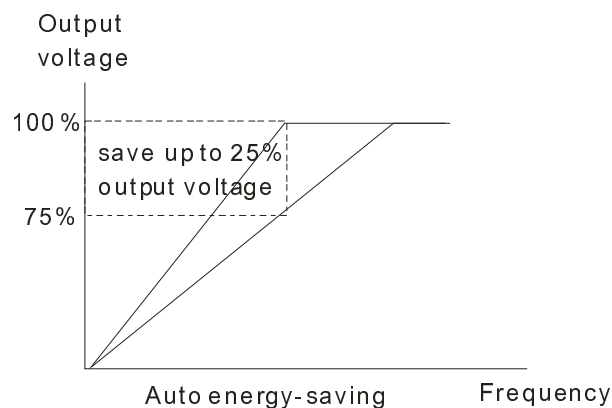

07-22 Energy-saving Gain

Factory Setting: 100

Settings 10~1000%

 When Pr.00-19 is set to 1, this parameter can be used to adjust the gain of energy-saving. The factory setting is 100%. If the result is not good, it can adjust by decreasing the setting. If the motor oscillates, it should increase the setting.

07-23 Auto Voltage Regulation(AVR) Function

Factory Setting: 0

Settings 0: Enable AVR

1: Disable AVR

2: Disable AVR during deceleration

 The rated voltage of the motor is usually 220V/200VAC 60Hz/50Hz and the input voltage of the AC motor drive may vary between 180V to 264 VAC 50Hz/60Hz. Therefore, when the AC motor drive is used without AVR function, the output voltage will be the same as the input voltage. When the motor runs at voltages exceeding the rated voltage with 12% - 20%, its lifetime will be shorter and it can be damaged due to higher temperature, failing insulation and unstable torque output.

- 📖 AVR function automatically regulates the AC motor drive output voltage to the motor rated voltage. For instance, if V/f curve is set at 200 VAC/50Hz and the input voltage is at 200V to 264VAC, then the motor Output Voltage will automatically be reduced to a maximum of 200VAC/50Hz. If the input voltage is at 180V to 200VAC, output voltage to motor and input power will be in direct proportion.
- 📖 Setting 0: when AVR function is enabled, the drive will calculate the output voltage by actual DC-bus voltage. The output voltage won't be changed by DC bus voltage.
- 📖 Setting 1: when AVR function is disabled, the drive will calculate the output voltage by DC-bus voltage. The output voltage will be changed by DC bus voltage. It may cause insufficient/over current.
- 📖 Setting 2: the drive will disable the AVR during deceleration, such as operated from high speed to low speed.
- 📖 When the motor ramps to stop, the deceleration time is longer. When setting this parameter to 2 with auto acceleration/deceleration, the deceleration will be quicker.
- 📖 When it is in FOCPG or TQCPG, it is recommended to set to 0 (enable AVR).

↗ **07-24** Filter Time of Torque Command (V/F and SVC control mode) Factory Setting: 0.020

Settings 0.001~10.000 sec

- 📖 When the setting is too long, the control will be stable but the control response will be delay. When the setting is too short, the response will be quickly but the control may be unstable. User can adjust the setting by the control and response situation.

↗ **07-25** Filter Time of Slip Compensation (V/F and SVC control mode) Factory Setting: 0.100

Settings 0.001~10.000 sec

- 📖 It can set Pr.05-22 and 05-23 to change the response time of compensation.
- 📖 If Pr.05-22 and 05-23 are set to 10seconds, the response time of compensation is the slowest. But the system may be unstable when the setting is too short.

↗ **07-26** Torque Compensation Gain (V/F and SVC control mode) Factory Setting: 0





Settings 0~10

- 📖 When the motor load is large, a part of drive output voltage is absorbed by the resistor of stator winding and causes insufficient voltage at motor induction and result in over output current and insufficient output torque. It can auto adjust output voltage by the load and keep the air gap magnetic fields stable to get the optimal operation.
- 📖 In the V/F control, the voltage will be decreased in direct proportion when the frequency is decreased. It'll cause decrease torque at low speed due to small AC resistor and the same DC resistor. Therefore, Auto torque compensation function will increase the output voltage in the low frequency to get higher start torque.
- 📖 When Pr.07-26 is set to large, it may cause motor overflux and result in too large output current, motor overheat or triggers protection function.

07-27 Slip Compensation Gain (V/F and SVC control mode)

Factory Setting: 0.00

Settings 0.00~10.00

-  The induction motor needs the constant slip to produce magnetic torque. It can be ignore in the higher motor speed, such as rated speed or 2-3% slip.
-  In the operation with variable frequency, the slip and the synchronous frequency will be in reverse proportion to produce the same magnetic torque. That is the slip will be larger with the reduction of synchronous frequency. The motor may stop when the synchronous frequency is decreased to a specific value. Therefore, the slip serious affects the accuracy of motor speed at low speed.
-  In another situation, when the drive uses with induction motor, the slip will be increased by the increasing load. It also affects the accuracy of motor speed.
-  This parameter can be used to set compensation frequency and reduce the slip to close the synchronous speed when the motor runs in the rated current to raise the drive accuracy. When the drive output current is larger than Pr.05-05 No-load Current of Induction Motor 1 (A), the drive will compensation the frequency by this parameter.
-  When the control method (Pr.00-11) is changed from V/f mode to vector mode, this parameter will auto be set to 1.00. Otherwise, it will be set to 0.00. Please do the compensation of slip after overload and acceleration. The compensation value should be increased from small to large gradually. That is to add the output frequency with motor rated slip X Pr.07-27 Slip Compensation Gain when the motor is rated load. If the actual speed ratio is slow than expectation, please increase the setting. Otherwise, decrease the setting.

07-28 Reserved

07-29 Slip Deviation Level

Factory Setting: 0

Settings 0~100.0%

0: No detection

07-30 Detection Time of Slip Deviation

Factory Setting:1.0

Settings 0.0~10.0 sec

07-31 Over Slip Treatment

Factory Setting:0

Settings

- 0: Warn and keep operation
- 1: Warn and ramp to stop
- 2: Warn and coast to stop
- 3: No warning

-  Pr.07-29 to Pr.07-31 are used to set allowable slip level/time and over slip treatment when the drive is running.

↗ **07-32** Motor Hunting Gain

Factory Setting:1000

Settings 0~10000
0: Disable

📖 The motor will have current wave motion in some specific area. It can improve this situation by setting this parameter. (When it is high frequency or run with PG, it can be set to 0. when the current wave motion happens in the low frequency, please increase Pr.05-29.)

↗ **07-33** Recovery Time to Pr.07-11 (# of automatic reboots after fault)

Factory Setting:60.0

Settings 0.0~6000.0 sec

📖 When a reset/restart after fault occurs, the drive will regards Pr.07-33 as a time boundary and begin counting the numbers of faults occur within this time period. Within the period, if numbers of faults occurred did not exceed the setting in Pr.07-11, the counting will be cleared and starts from 0 when next fault occurs. However, if the numbers of faults occurred within this time period have exceed the setting in Pr.07-11, user will need to press RESET key manually for the drive to operate again.

07-34
~ Reserved
07-37

↗ **07-38** Speed Tracking on Frequency Derivative

Factory Setting: 1

Settings 1~500

08 High-function PID Parameters

✈ This parameter can be set during operation.

08-00	Input Terminal for PID Feedback
-------	---------------------------------

Factory Setting:0

- Settings
- 0: No function
 - 1: Negative PID feedback: input from external terminal AVI (Pr.03-00)
 - 2: Reserved
 - 3: Reserved
 - 4: Positive PID feedback from external terminal AVI (Pr.03-00)

📖 Negative feedback means: +target value – feedback. It is used for the detection value will be increased by increasing the output frequency.

📖 Positive feedback means: -target value + feedback. It is used for the detection value will be decreased by increasing the output frequency.

Common applications for PID control

- ☑ Flow control: A flow sensor is used to feedback the flow data and performs accurate flow control.
- ☑ Pressure control: A pressure sensor is used to feedback the pressure data and performs precise pressure control.
- ☑ Air volume control: An air volume sensor is used to feedback the air volume data to have excellent air volume regulation.
- ☑ Temperature control: A thermocouple or thermistor is used to feedback temperature data for comfortable temperature control.
- ☑ Speed control: A speed sensor or encoder is used to feedback motor shaft speed or input another machines speed as a target value for closed loop speed control of master-slave operation. Pr.10.00 sets the PID set point source (target value).
- ☑ PID control operates with the feedback signal as set by Pr.10.01 either 0~+10V voltage or 4-20mA current.

📖 PID control loop:

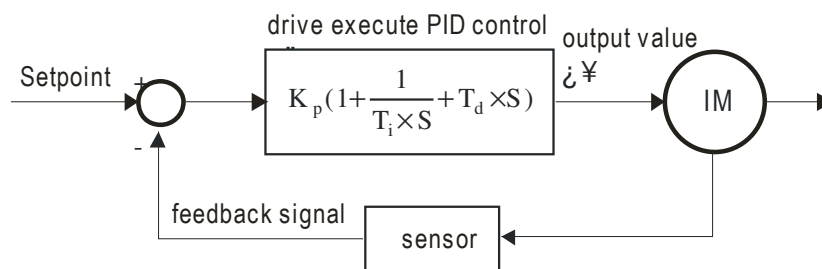

K_p : Proportional gain(P) T_i : Integral time(I) T_d : Derivative control(D) S: Operator

📖 Concept of PID control

1. Proportional gain(P):
the output is proportional to input. With only proportional gain control, there will always be a steady-state error.
2. Integral time(I):
the controller output is proportional to the integral of the controller input. To eliminate the steady-state error, an “integral part” needs to be added to the controller. The integral time

decides the relation between integral part and error. The integral part will be increased by time even if the error is small. It gradually increases the controller output to eliminate the error until it is 0. In this way a system can be stable without steady-state error by proportional gain control and integral time control.

3. Differential control(D):

the controller output is proportional to the differential of the controller input. During elimination of the error, oscillation or instability may occur. The differential control can be used to suppress these effects by acting before the error. That is, when the error is near 0, the differential control should be 0. Proportional gain(P) + differential control(D) can be used to improve the system state during PID adjustment.

 When PID control is used in a constant pressure pump feedback application:

Set the application's constant pressure value (bar) to be the set point of PID control. The pressure sensor will send the actual value as PID feedback value. After comparing the PID set point and PID feedback, there will be an error. Thus, the PID controller needs to calculate the output by using proportional gain(P), integral time(I) and differential time(D) to control the pump. It controls the drive to have different pump speed and achieves constant pressure control by using a 4-20mA signal corresponding to 0-10 bar as feedback to the drive.

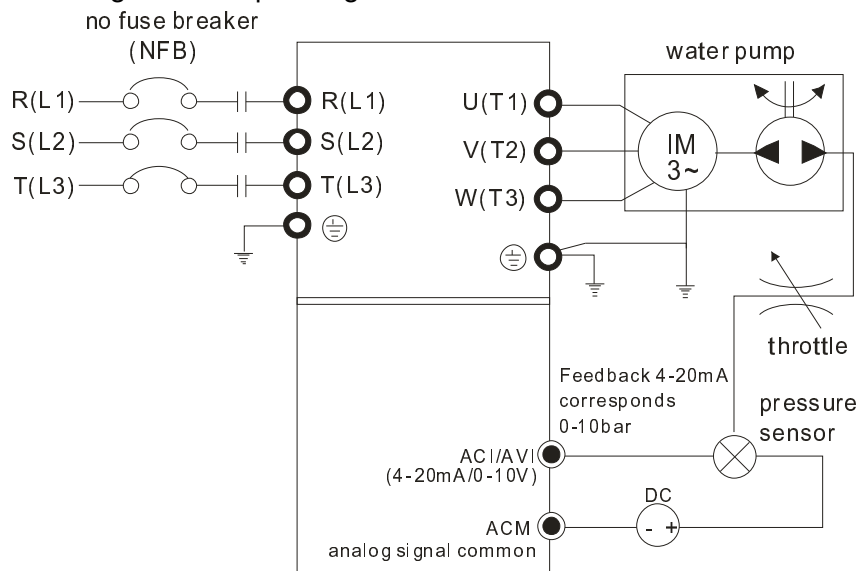

1. Pr.00-04 is set to 10 (Display PID analog feedback signal value (b) (%))
2. Pr.01-12 Acceleration Time will be set as required
3. Pr.01-13 Deceleration Time will be set as required
4. Pr.00-21=0 to operate from the digital keypad
5. Pr.00-20=0, the set point is controlled by the digital keypad
6. Pr.08-00=1 (Negative PID feedback from analog input)
7. ACI analog input Pr. 03-01 set to 5, PID feedback signal.
8. Pr.08-01-08-03 will be set as required
 - 8.1 If there is no vibration in the system, increase Pr.08-01(Proportional Gain (P))
 - 8.2 If there is no vibration in the system, reduce Pr.08-02(Integral Time (I))
 - 8.3 If there is no vibration in the system, increase Pr.08-03(Differential Time(D))

 Refer to Pr.08-00 to 08-21 for PID parameters settings.

08-01 Proportional Gain (P)

Factory Setting:80.0

Settings 0.0~500.0%

- It is used to eliminate the system error. It is usually used to decrease the error and get the faster response speed. But if setting too large value in Pr.08-01, it may cause the system oscillation and instability.
- If the other two gains (I and D) are set to zero, proportional control is the only one effective.

08-02 Integral Time (I)

Factory Setting:1.00

Settings 0.00~100.00 sec

0.00: Disable

- 📖 The integral controller is used to eliminate the error during stable system. The integral control doesn't stop working until error is 0. The integral is acted by the integral time. The smaller integral time is set, the stronger integral action will be. It is helpful to reduce overshoot and oscillation to make a stable system. At this moment, the decreasing error will be slow. The integral control is often used with other two controls to become PI controller or PID controller.
- 📖 This parameter is used to set the integral time of I controller. When the integral time is long, it will have small gain of I controller, the slower response and bad external control. When the integral time is short, it will have large gain of I controller, the faster response and rapid external control.
- 📖 When the integral time is too small, it may cause system oscillation.
- 📖 If the integral time is set as 0.00, Pr.08-02 will be disabled.

08-03 Derivative Control (D)

Factory Setting:0.00



Settings 0.00~1.00 sec

- 📖 The differential controller is used to show the change of system error and it is helpful to preview the change of error. So the differential controller can be used to eliminate the error to improve system state. With the suitable differential time, it can reduce overshoot and shorten adjustment time. However, the differential operation will increase the noise interference. Please note that too large differential will cause big noise interference. Besides, the differential shows the change and the output of the differential will be 0 when there is no change. Therefore, the differential control can't be used independently. It needs to be used with other two controllers to make a PD controller or PID controller.
- 📖 This parameter can be used to set the gain of D controller to decide the response of error change. The suitable differential time can reduce the overshoot of P and I controller to decrease the oscillation and have a stable system. But too long differential time may cause system oscillation.
- 📖 The differential controller acts for the change of error and can't reduce the interference. It is not recommended to use this function in the serious interference.

08-04 Upper limit of Integral Control

Factory Setting:100.0

Settings 0.0~100.0%

-  This parameter defines an upper bound or limit for the integral gain (I) and therefore limits the Master Frequency. The formula is: Integral upper bound = Maximum Output Frequency (Pr.01-00) x (Pr.08-04 %).
-  Too large integral value will make the slow response due to sudden load change. In this way, it may cause motor stall or machine damage.

08-05 PID Output Frequency Limit

Factory Setting:100.0

Settings 0.0~110.0%

-  This parameter defines the percentage of output frequency limit during the PID control. The formula is Output Frequency Limit = Maximum Output Frequency (Pr.01-00) X Pr.08-05 %.

08-06 Reserved

08-07 PID Delay Time





Factory Setting: 0.0

Settings 0.0~35.0 sec

08-20 PID Mode Selection

Factory Setting: 0

 Settings 0: Serial connection
 1: Parallel connection

-  Pr.08-07 determines the primary low pass filter time when in PID control. Setting a large time constant may slow down the response rate of drive.
-  Output frequency of PID control will filter by primary low pass function. This function could filtering a mix frequencies. A long primary low pass time means filter degree is high and vice versa.
-  Inappropriate setting of delay time may cause system error.
-  PI Control: controlled by the P action only, and thus, the deviation cannot be eliminated entirely. To eliminate residual deviations, the P + I control will generally be utilized. And when the PI control is utilized, it could eliminate the deviation incurred by the targeted value changes and the constant external interferences. However, if the I action is excessively powerful, it will delay the responding toward the swift variation. The P action could be used solely on the loading system that possesses the integral components.
-  PD Control: when deviation occurred, the system will immediately generate some operation load that is greater than the load generated single handedly by the D action to restrain the increment of the deviation. If the deviation is small, the effectiveness of the P action will be decreasing as well. The control objects include occasions with integral component loads, which are controlled by the P action only, and sometimes, if the integral component is functioning, the whole system will be vibrating. On such occasions, in order to make the P action's vibration subsiding and the

system stabilizing, the PD control could be utilized. In other words, this control is good for use with loadings of no brake functions over the processes.

 **PID Control:** Utilize the I action to eliminate the deviation and the D action to restrain the vibration, thereafter, combine with the P action to construct the PID control. Use of the PID method could obtain a control process with no deviations, high accuracies and a stable system.

 **Serial connection**

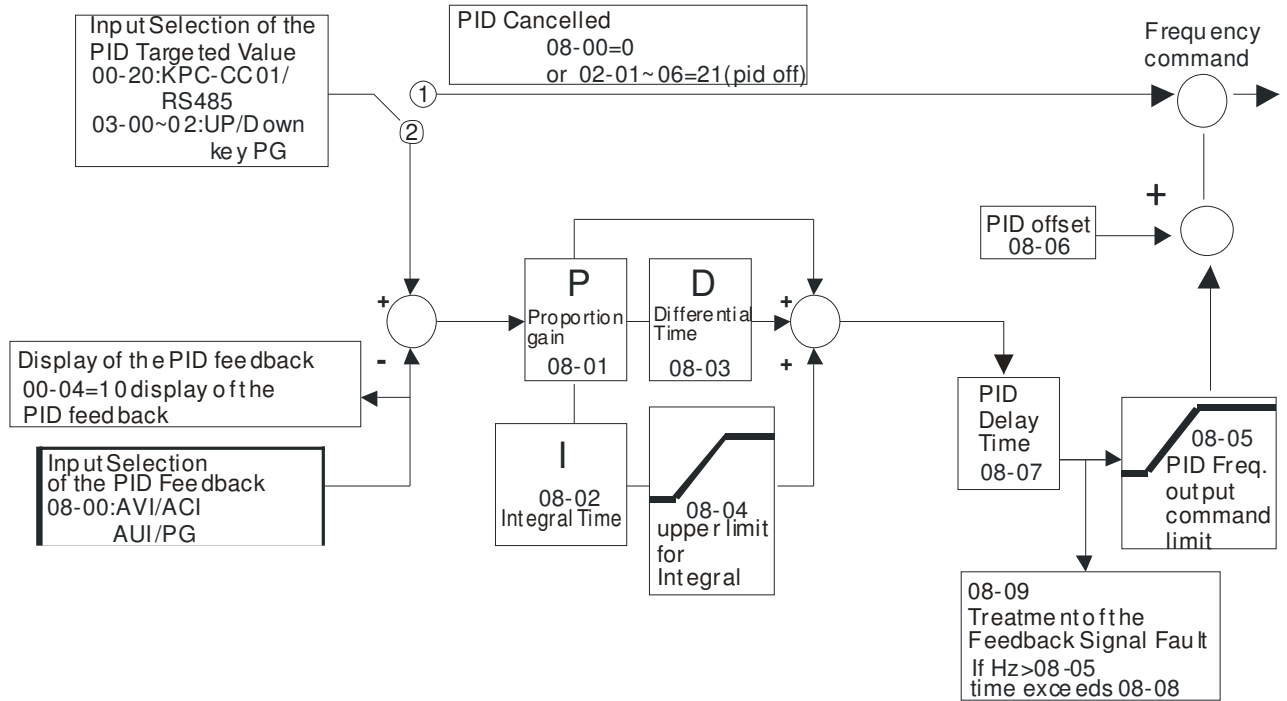

 **Parallel connection**

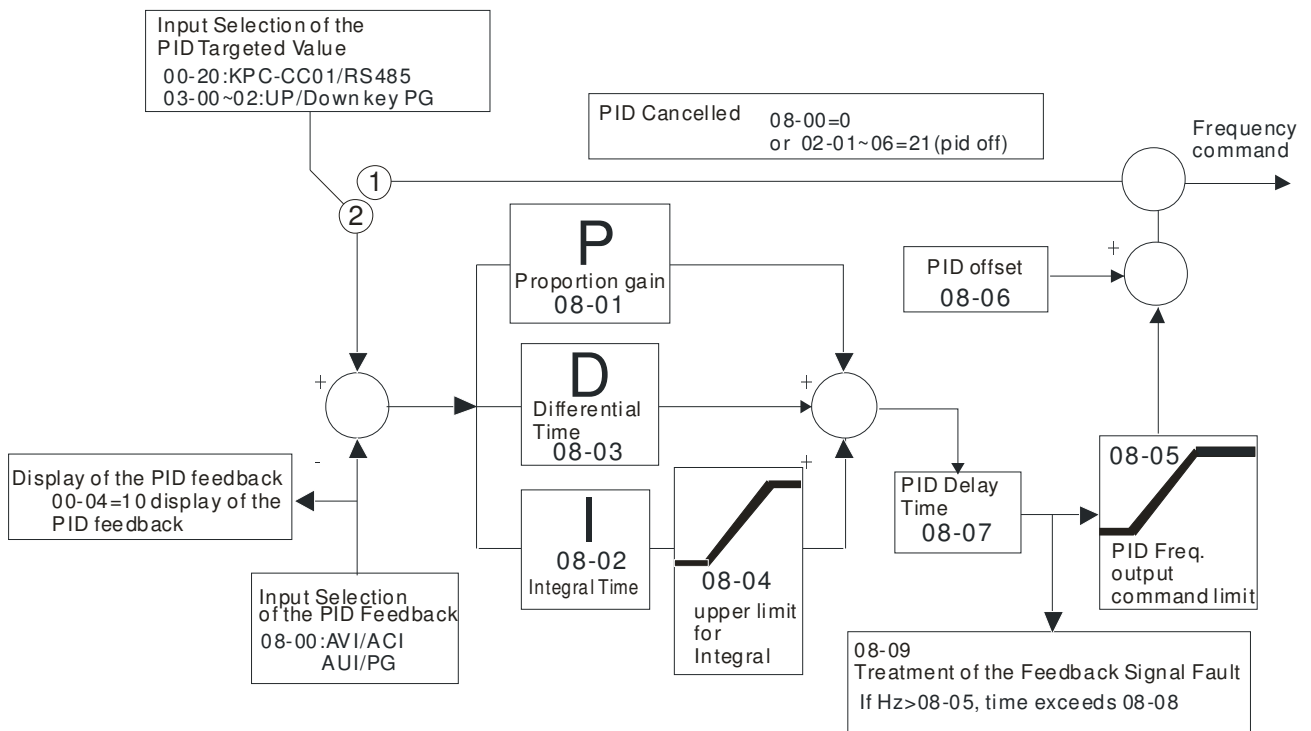

➤ **08-08** Feedback Signal Detection Time

Factory Setting: 0.0

Settings 0.0~3600.0 sec

- 📖 Pr.08-08 is valid only if the feedback signal is ACI.
- 📖 This parameter sets the detection time of abnormal PID derivative. If detection time is set to 0.0, detection function is disabled.

08-09 Feedback Signal Fault Treatment

Factory Setting: 0

Settings 0: Warn and keep operation
 1: Warn and ramp to stop
 2: Warn and coast to stop
 3: Warn and operate at last frequency

- 📖 This parameter is valid only when the feedback signal is ACI.
- 📖 AC motor drive acts when the feedback signals (analog PID feedback or PG (encoder) feedback) are abnormal.

➤ **08-10** Sleep Frequency

Factory Setting: 0.00

Settings Pr.08-18=0: 0.00~600.00Hz
 Pr.08-18=1: 0.00~200.00%

➤ **08-11** Wake-up Frequency

Factory Setting: 0.00

Settings Pr.08-18=0: 0.00~600.00Hz
 Pr.08-18=1: 0.00~200.00%



➤ **08-12** Sleep Time

Factory Setting: 0.0

Settings 0.00~6000.0 sec

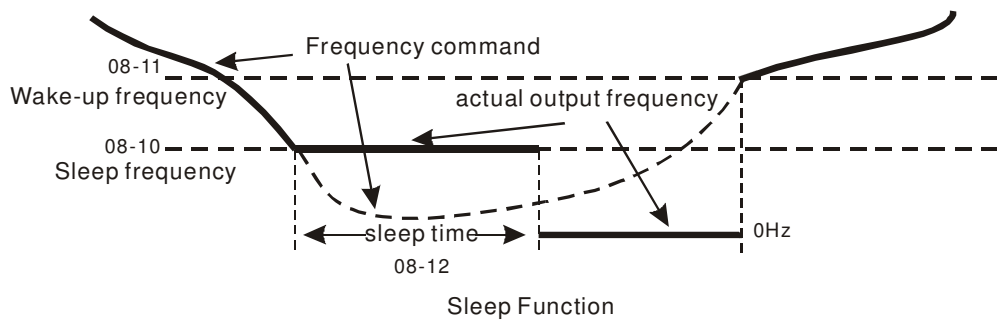
- 📖 If the command frequency falls below the sleep frequency, for the specified time in Pr. 08-12, then the drive will shut off the output and wait until the command frequency rises above Pr.08-11.



↗	08-13 PID Deviation Level	Factory Setting: 10.0
	Settings 1.0~50.0%	
↗	08-14 PID Deviation Time	Factory Setting: 5.0
	Settings 0.1~300.0 sec	
↗	08-15 Filter Time for PID Feedback	Factory Setting: 5.0
	Settings 0.1~300.0 sec	
	<p> When the PID control function is normal, it should calculate within a period of time and close to the setpoint value.</p> <p> Refer to the PID control diagram for details. When executing PID feedback control, if $\text{PID reference target value} - \text{detection value} > \text{Pr.08-13 PID Deviation Level}$ and exceeds Pr.08-14 setting, the PID control fault occurs. The treatment will be done as Pr.08-09 setting.</p>	
↗	08-16 PID Compensation Selection	Factory Setting: 0
	Settings 0: Parameter setting 1: Analog input	
↗	08-17 PID Compensation	Factory Setting: 0
	Settings -100.0~+100.0%	
	08-18 Setting of Sleep Mode Function	Factory Setting: 0
	Settings 0: Follow PID output command 1: Follow PID feedback signal	
	08-19 Wake-up Integral Limit	Factory Setting: 50.0
	Settings 0.0~200.0%	
	 The upper limit when the VFD is at sleep mode to avoid running at high speed right after being waken up.	

There are three types of Sleep mode and Wakeup mode.

01: Frequency command(Not using PID, Pr08-00=0)

Output Frequency \leq Sleep Frequency, the drive goes to Sleep mode, 0Hz.

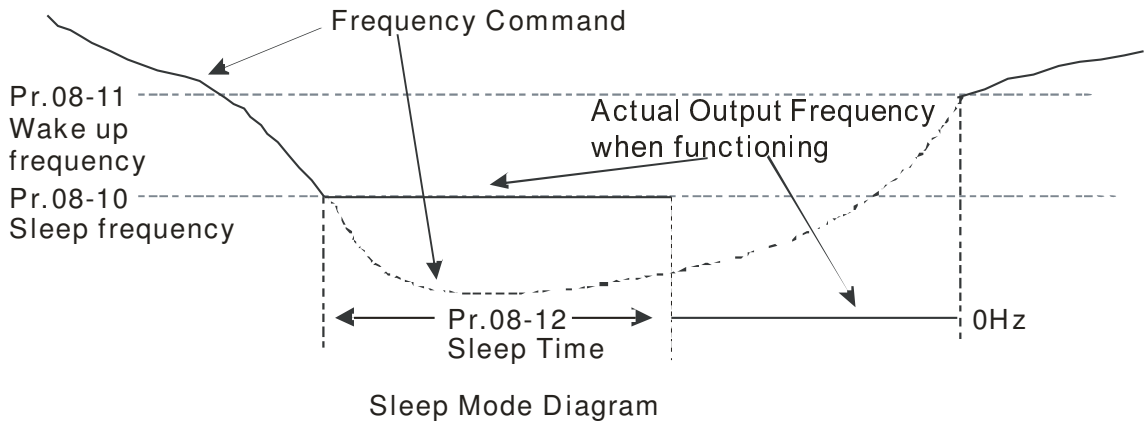

02: Internal PID Frequency Calculation Command (Not using PID, Pr08 ≠ 0)

When arriving at the sleep frequency, the system starts to calculating sleep time and the output frequency starts to decrease. If it passes the preset sleep time, the system will go to seelp at 0Hz.

If the system is not yet reaching the preset sleep time, (if there is a preset) or will stay at Pr01-07, waiting to reach the sleep time then go to sleep at 0Hz.

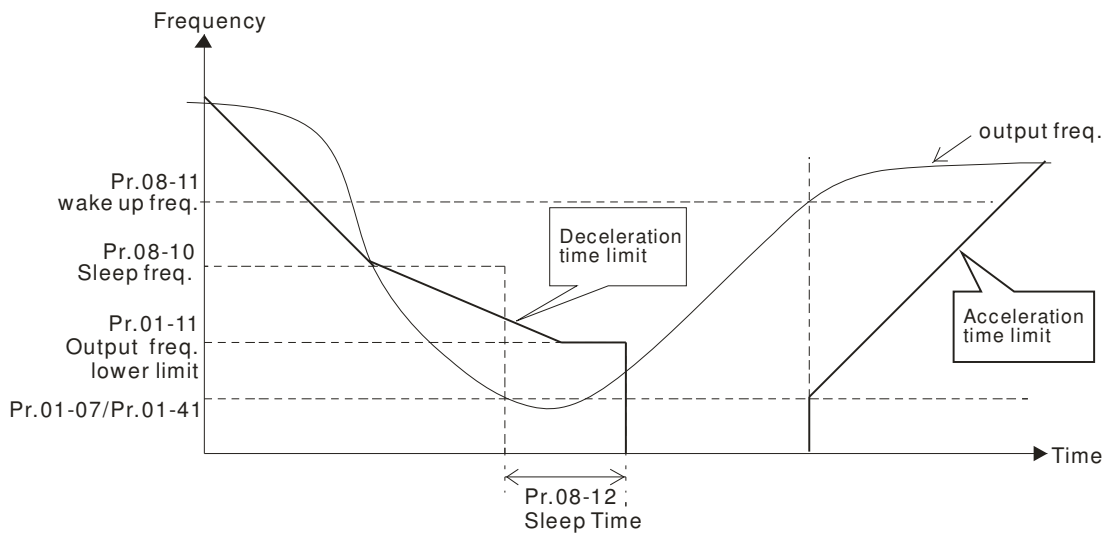

03: Percentage of PID's Target Value (Set PID, Pr08-00 ≠ 0)

When reaching the percentage of PID's Target Value and the percentage of the feedback value, the system.

Starts to calculate the sleep time. The output frequency decreases immediately. If the system passes the preset sleep time, it will go to sleep at 0Hz. However, if it doesn't reach the preset sleep time, it will remain at Pr01-11 (if there is a preset value) or Pr01-07 waiting to reach the sleep time then go to sleep at 0Hz.

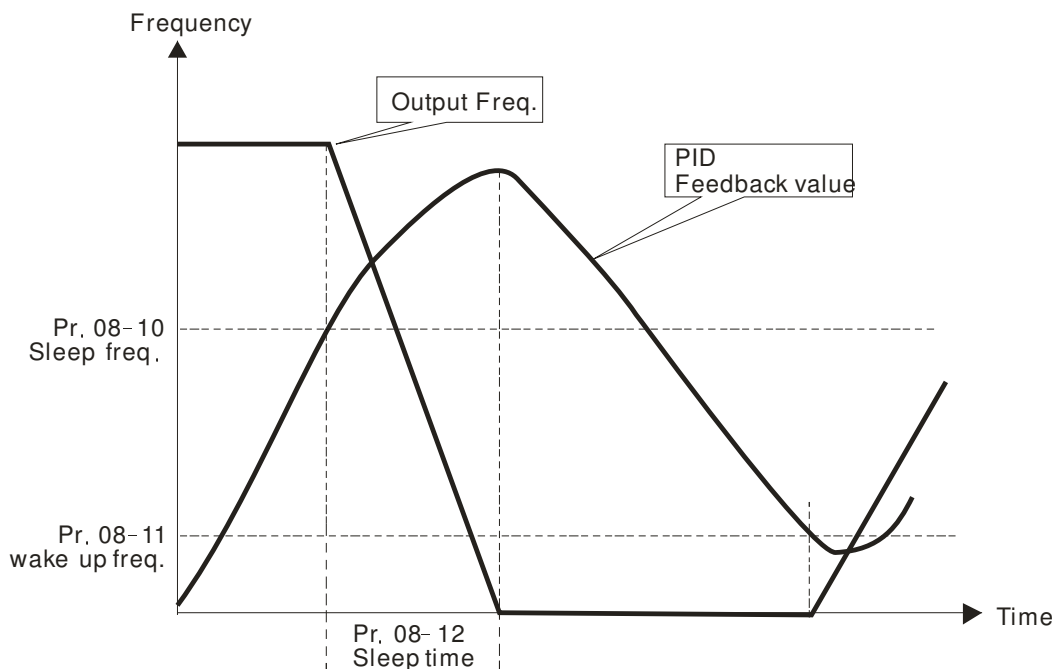

📖 Enable or disable the Sleep and Wakeup functions depends on the setting of Pr08-10. When Pr08-10=0, it means Disable, while Pr08-10 ≠ 0, it means Enable.

08-21	Enable PID to Change the Operation Direction	Factory Setting: 0
Settings	0: Disable change of direction 1: Enable change of direction	

09 Communication Parameters

↗ The parameter can be set during the operation.

When using communication devices, connects AC drive with PC by using Delta IFD6530 or IFD6500.

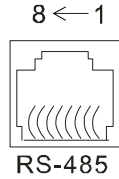

Modbus RS-485
 Pin 1~2,7,8: Reserved
 Pin 3, 6: GND
 Pin 4: SG-
 Pin 5: SG+

↗ **09-00** COM1 Communication Address

Factory Setting: 1

Settings 1~254

📖 If the AC motor drive is controlled by RS-485 serial communication, the communication address for this drive must be set via this parameter. And the communication address for each AC motor drive must be different and unique.

↗ **09-01** COM1 Transmission Speed

Factory Setting: 9.6

Settings 4.8~115.2 Kbps

📖 This parameter is used to set the transmission speed between the RS485 master (PLC, PC, etc.) and AC motor drive.

↗ **09-02** COM1 Transmission Fault Treatment

Factory Setting: 3

Settings 0: Warn and keep operation
 1: Warn and ramp to stop
 2: Warn and coast to stop
 3: No warning and continue operation

📖 This parameter is set to how to react if transmission errors occur.

↗ **09-03** COM1 Time-out Detection

Factory Setting: 0.0

Settings 0.0~100.0 sec.
 0.0: Disable



📖 It is used to set the transmission time between communication and keypad.

↗ **09-04** COM1 Communication Protocol

Factory Setting: 1

Settings 0: 7, N, 1 for ASCII
 1: 7, N, 2 for ASCII
 2: 7, E, 1 for ASCII
 3: 7, O, 1 for ASCII
 4: 7, E, 2 for ASCII
 5: 7, O, 2 for ASCII
 6: 8, N, 1 for ASCII
 7: 8, N, 2 for ASCII

- 8: 8, E, 1 for ASCII
- 9: 8, O, 1 for ASCII
- 10: 8, E, 2 for ASCII
- 11: 8, O, 2 for ASCII
- 12: 8, N, 1 for RTU
- 13: 8, N, 2 for RTU
- 14: 8, E, 1 for RTU
- 15: 8, O, 1 for RTU
- 16: 8, E, 2 for RTU
- 17: 8, O, 2 for RTU

-  Control by PC or PLC (Computer Link)
-  A VFD-C2000 can be set up to communicate on Modbus networks using one of the following modes: ASCII (American Standard Code for Information Interchange) or RTU (Remote Terminal Unit). Users can select the desired mode along with the RS-485 serial port communication protocol in Pr.09-00.
-  MODBUS ASCII (American Standard Code for Information Interchange) : Each byte data is the combination of two ASCII characters. For example, a 1-byte data: 64 Hex, shown as '64' in ASCII, consists of '6' (36Hex) and '4' (34Hex).

1. Code Description

Communication protocol is in hexadecimal, ASCII: "0", "9", "A", "F", every 16 hexadecimal represent ASCII code. For example:

Character	'0'	'1'	'2'	'3'	'4'	'5'	'6'	'7'
ASCII code	30H	31H	32H	33H	34H	35H	36H	37H
Character	'8'	'9'	'A'	'B'	'C'	'D'	'E'	'F'
ASCII code	38H	39H	41H	42H	43H	44H	45H	46H

2. Data Format

10-bit character frame (For ASCII):

(7, N, 2)

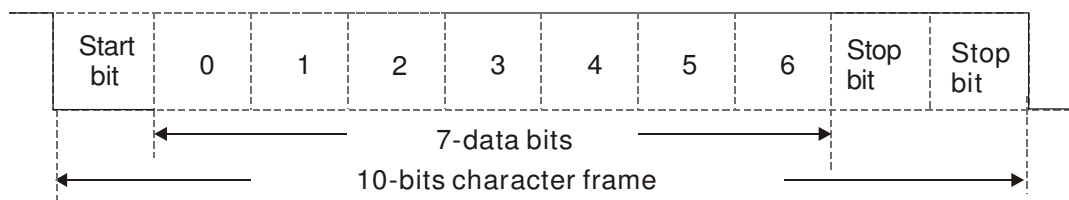

(7, E, 1)

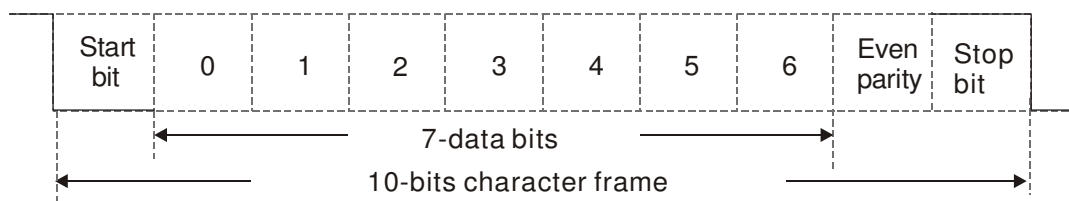

(7, O, 1)

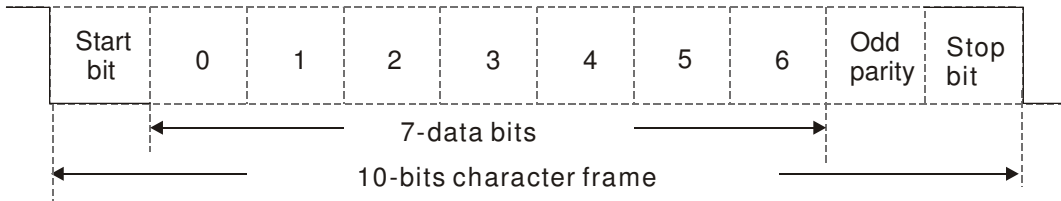

11-bit character frame (For RTU):

(8, N, 2)

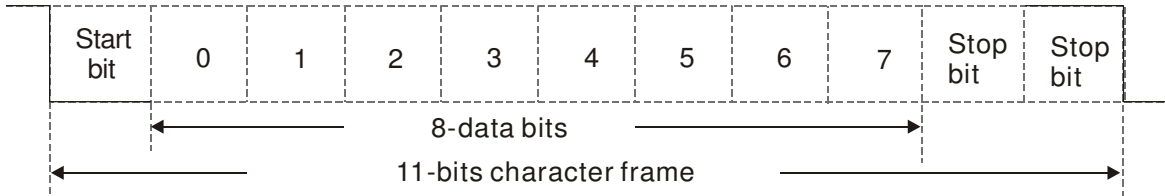

(8, E, 1)

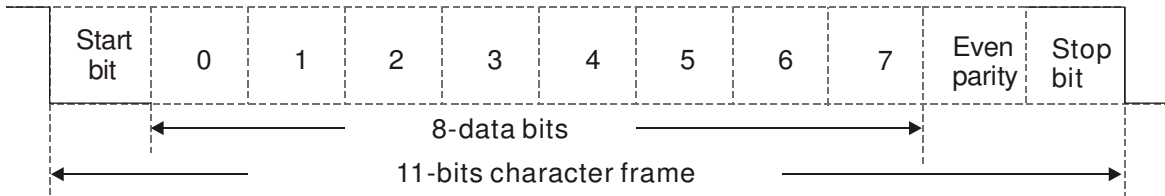

(8, O, 1)

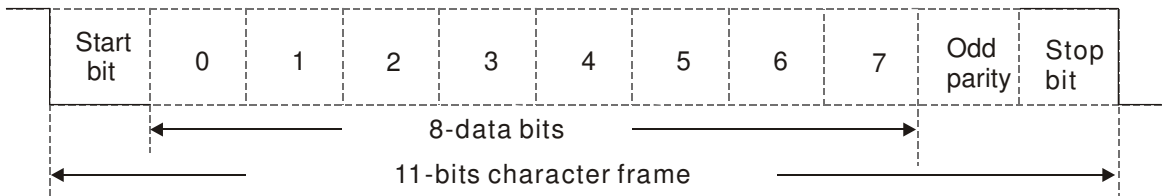

3. Communication Protocol

Communication Data Frame: **ASCII mode**

STX	Start character = ':' (3AH)
Address Hi	Communication address: 8-bit address consists of 2 ASCII codes
Address Lo	
Function Hi	Command code: 8-bit command consists of 2 ASCII codes
Function Lo	
DATA (n-1)	Contents of data: Nx8-bit data consist of 2n ASCII codes n<=16, maximum of 32 ASCII codes
.....	
DATA 0	
LRC CHK Hi	LRC check sum: 8-bit check sum consists of 2 ASCII codes
LRC CHK Lo	
END Hi	End characters: END1= CR (0DH), END0= LF(0AH)
END Lo	

Communication Data Frame: **RTU** mode

START	A silent interval of more than 10 ms
Address	Communication address: 8-bit address
Function	Command code: 8-bit command
DATA (n-1)	Contents of data: n×8-bit data, n≤16
.....	
DATA 0	
CRC CHK Low	CRC check sum: 16-bit check sum consists of 2 8-bit characters
CRC CHK High	
END	A silent interval of more than 10 ms

Address (Communication Address)

Valid communication addresses are in the range of 0 to 254. A communication address equal to 0, means broadcast to all AC drives (AMD). In this case, the AMD will not reply any message to the master device.

00H: broadcast to all AC drives

01H: AC drive of address 01

0FH: AC drive of address 15

10H: AC drive of address 16

:

FEH: AC drive of address 254

Function (Function code) and DATA (data characters)

The format of data characters depends on the function code.

03H: read data from register

06H: write single register

Example: reading continuous 2 data from register address 2102H, AMD address is 01H.

ASCII mode:

Command Message:

STX	‘.’
Address	‘0’
	‘1’
Function	‘0’
	‘3’
Starting address	‘2’
	‘1’
	‘0’
	‘2’
Number of data (count by word)	‘0’
	‘0’
	‘2’
	‘2’
LRC Check	‘D’
	‘7’
END	CR
	LF

Response Message

STX	‘.’
Address	‘0’
	‘1’
Function	‘0’
	‘3’
Number of data (count by byte)	‘0’
	‘4’
Content of starting address 2102H	‘1’
	‘7’
	‘7’
	‘0’
Content of address 2103H	‘0’
	‘0’
	‘0’
	‘0’
LRC Check	‘7’
	‘1’
END	CR
	LF

RTU mode:

Command Message:		Response Message	
Address	01H	Address	01H
Function	03H	Function	03H
Starting data address	21H	Number of data (count by byte)	04H
	02H		Content of data address 2102H
Number of data (count by word)	00H	17H	
	02H	70H	
CRC CHK Low	6FH	Content of data address 2103H	00H
CRC CHK High	F7H	00H	
		CRC CHK Low	FEH
		CRC CHK High	5CH

06H: single write, write single data to register.

Example: writing data 6000(1770H) to register 0100H. AMD address is 01H.

ASCII mode:

Command Message:		Response Message	
STX	‘.’	STX	‘.’
Address	‘0’	Address	‘0’
	‘1’		‘1’
Function	‘0’	Function	‘0’
	‘6’		‘6’
Data address	‘0’	Data address	‘0’
	‘1’		‘1’
	‘0’		‘0’
	‘0’		‘0’
Data content	‘1’	Data content	‘1’
	‘7’		‘7’
	‘7’		‘7’
	‘0’		‘0’
LRC Check	‘7’	LRC Check	‘7’
	‘1’		‘1’
END	CR	END	CR
	LF		LF

RTU mode:

Command Message:		Response Message	
Address	01H	Address	01H
Function	06H	Function	06H
Data address	01H	Data address	01H
	00H		00H
Data content	17H	Data content	17H
	70H		70H
CRC CHK Low	86H	CRC CHK Low	86H
CRC CHK High	22H	CRC CHK High	22H

10H: write multiple registers (write multiple data to registers)

Example: Set the multi-step speed,

Pr.04-00=50.00 (1388H), Pr.04-01=40.00 (0FA0H). AC drive address is 01H.

ASCII Mode

Command Message:		Response Message	
STX	':'	STX	':'
ADR 1	'0'	ADR 1	'0'
ADR 0	'1'	ADR 0	'1'
CMD 1	'1'	CMD 1	'1'
CMD 0	'0'	CMD 0	'0'
Starting data address	'0'	Starting data address	'0'
	'5'		'5'
	'0'		'0'
	'0'		'0'
Number of data (count by word)	'0'	Number of data (count by word)	'0'
	'0'		'0'
	'0'		'0'
	'2'		'2'
Number of data (count by byte)	'0'	LRC Check	'E'
	'4'		'8'
The first data content	'1'	END	CR
	'3'		LF
	'8'		
	'8'		
The second data content	'0'		
	'F'		
	'A'		
	'0'		
LRC Check	'9'		
	'A'		
END	CR		
	LF		

RTU mode:

Command Message:		Response Message	
ADR	01H	ADR	01H
CMD	10H	CMD 1	10H
Starting data address	05H	Starting data address	05H
	00H		00H
Number of data (count by word)	00H	Number of data (count by word)	00H
	02H		02H
Number of data (count by byte)	04	CRC Check Low	41H
The first data content	13H	CRC Check High	04H
	88H		
The second data content	0FH		
	A0H		
CRC Check Low	'9'		
CRC Check High	'A'		

Check sum

ASCII mode:

LRC (Longitudinal Redundancy Check) is calculated by summing up, module 256, and the values of the bytes from ADR1 to last data character then calculating the hexadecimal representation of the 2's-complement negation of the sum.

For example,

$01H+03H+21H+02H+00H+02H=29H$, the 2's-complement negation of 29H is **D7H**.

RTU mode:

CRC (Cyclical Redundancy Check) is calculated by the following steps:

Step 1:

Load a 16-bit register (called CRC register) with FFFFH.

Step 2:

Exclusive OR the first 8-bit byte of the command message with the low order byte of the 16-bit CRC register, putting the result in the CRC register.

Step 3:

Examine the LSB of CRC register.

Step 4:

If the LSB of CRC register is 0, shift the CRC register one bit to the right with MSB zero filling, then repeat step 3. If the LSB of CRC register is 1, shift the CRC register one bit to the right with MSB zero filling, Exclusive OR the CRC register with the polynomial value A001H, then repeat step 3.

Step 5:

Repeat step 3 and 4 until eight shifts have been performed. When this is done, a complete 8-bit byte will have been processed.

Step 6:

Repeat step 2 to 5 for the next 8-bit byte of the command message. Continue doing this until all bytes have been processed. The final contents of the CRC register are the CRC value. When transmitting the CRC value in the message, the upper and lower bytes of the CRC value must be swapped, i.e. the lower order byte will be transmitted first.

The following is an example of CRC generation using C language. The function takes two arguments:

Unsigned char* data ← a pointer to the message buffer

Unsigned char length ← the quantity of bytes in the message buffer

The function returns the CRC value as a type of unsigned integer.

Unsigned int crc_chk(unsigned char* data, unsigned char length)

```
{
    int j;
    unsigned int reg_crc=0Xffff;
    while(length--){
```

```

reg_crc ^= *data++;
for(j=0;j<8;j++){
if(reg_crc & 0x01){ /* LSB(b0)=1 */
    reg_crc=(reg_crc>>1) ^ 0Xa001;
}else{
    reg_crc=reg_crc >>1;
}
}
}
}

return reg_crc; // return register CRC

```

4. Address list

Content	Address	Function	
AC drive Parameters	GGnnH	GG means parameter group, nn means parameter number, for example, the address of Pr 4-01 is 0401H.	
Command Write only	2000H	bit 0-3	0: No function 1: Stop 2: Run 3: Jog + Run
		bit 4-5	00B: No function 01B: FWD 10B: REV 11B: Change direction
		bit 6-7	00B: 1st accel/decel 01B: 2nd accel/decel 10B: 3rd accel/decel 11B: 4th accel/decel
		bit 8-11	000B: master speed
			0001B: 1st accel/decel.
			0010B: 2nd accel/decel
			0011B: 3rd accel/decel
			0100B: 4th accel/decel
			0101B: 5th accel/decel
			0110B: 6th accel/decel
			0111B: 7th accel/decel
			1000B: 8th accel/decel
			1001B: 9th accel/decel
1010B: 10th accel/decel			
1011B: 11th accel/decel			
1100B: 12th accel/decel			
1101B: 13th accel/decel			
1110B: 14th accel/decel			
1111B: 15th accel/decel			
bit 12	1: enable bit06-11 function		
bit 13~14	00B: No function 01B: operated by digital keypad 10B: operated by Pr.00-21 setting 11B: change operation source		
bit 15	Reserved		

Content	Address	Function		
Command Write only	2001H	Frequency command		
	2002H	bit 0	1: EF (external fault) on	
		bit 1	1: Reset	
		bit 2	1: B.B. ON	
	bit 3-15	Reserved		
Status monitor Read only	2100H	Error code: refer to Pr.06-17 to Pr.06-22		
	2101H	bit 0	AC Drive Operation Status 00b: Drive stops 01b: Drive decelerating	
		bit 1	10b: Drive standby 11b: Drive operating	
		bit 2	1: JOG Command	
		bit 3	Operation Direction 00b: FWD run 01b: from REV run to FWD run	
		bit 4	10b: REV run 11b: from FWD run to REV run	
		bit 8	1: Master frequency controlled by communication interface	
		bit 9	1: Master frequency controlled by analog signal	
		bit 10	1: Operation command controlled by communication interface	
		bit 11	1: Parameter locked	
		bit 12	1: Enable to copy parameters from keypad	
		bit 13~15	Reserved	
	2102H	Frequency command (F)		
	2103H	Output frequency (H)		
	2104H	Output current (AXX.X.X)		
	2105H	DC-BUS Voltage (UXXX.X)		
	2106H	Output voltage (EXXX.X)		
	2107H	Current step number of Multi-Step Speed Operation		
	2108H	Reserved		
	2109H	Counter value		
	210AH	Power Factor Angle (XXX.X)		
	210BH	Output Torque (%)		
	210CH	Actual motor speed (rpm)		
	210DH	Number of PG feed back pulses		
	210FH	Power output (X.XXX)		
	2116H	Multi-function display (Pr.00-04)		
	211BH	Max. operation frequency (Pr.01-00) or Max. user defined value (Pr.00-26)		
	2200H	Display output current (A)		
	2201H	Display counter value of TRG terminal (c)		
	2202H	Display actual output frequency (H)		
	2203H	Display DC-BUS voltage (u)		
	2204H	Display output voltage of U, V, W (E)		
	2205H	Display output power angle of U, V, W (n)		
	2206H	Display actual motor speed kW of U, V, W (P)		
	2207H	Display motor speed in rpm estimated by the drive or encoder feedback (r00: positive speed, -00: negative speed)		
	2208H	Display positive/negative output torque in %, estimated by the drive (t0.0: positive torque, -0.0: negative torque)		
220AH	Display PID feedback value after enabling PID function in % (b)			
220BH	Display signal of AVI analog input terminal, 0-10V corresponds to 0-100% (1.)			

Content	Address	Function
	220CH	Display signal of ACI analog input terminal, 4-V20mA/0-10V corresponds to 0-100% (2.)
	220DH	Display signal of AUI analog input terminal, -10V~10V corresponds to -100~100% (3.)
	220EH	Display the IGBT temperature of drive power module in °C (c.)
	220FH	Display the temperature of capacitance in °C (i.)
	2210H	The status of digital input (ON/OFF), refer to Pr.02-12
	2211H	The status of digital output (ON/OFF), refer to Pr.02-18
	2212H	Display the multi-step speed that is executing (S)
	2213H	The corresponding CPU pin status of digital input (d.)
	2214H	The corresponding CPU pin status of digital output (O.)
	2218H	Position command tracing error (P.)
	2219H	Display times of counter overload (0.00~100.00%)
	221AH	Display GFF in % (G.)
	221BH	Display DCbus voltage ripples (Unit: Vdc) (r.)
	221CH	Display PLC register D1043 data (C)
	221DH	Display Pole of Permanent Magnet Motor
	221EH	User page displays the value in physical measure
	221FH	Output Value of Pr.00-05
	2222H	Fan speed of the drive
	2223H	Control mode of the drive 0: speed mode 1: torque mode
	2224H	Carrier frequency of the drive

5. Exception response:

The AC motor drive is expected to return a normal response after receiving command messages from the master device. The following depicts the conditions when no normal response is replied to the master device.

The AC motor drive does not receive the messages due to a communication error; thus, the AC motor drive has no response. The master device will eventually process a timeout condition.

The AC motor drive receives the messages without a communication error, but cannot handle them. An exception response will be returned to the master device and an error message "CExx" will be displayed on the keypad of AC motor drive. The xx of "CExx" is a decimal code equal to the exception code that is described below.

In the exception response, the most significant bit of the original command code is set to 1, and an exception code which explains the condition that caused the exception is returned.

Example:

ASCII mode:		RTU mode:	
STX	‘.’	Address	01H
Address	‘0’	Function	86H
	‘1’	Exception code	02H
Function	‘8’	CRC CHK Low	C3H
	‘6’	CRC CHK High	A1H
Exception code	‘0’		
	‘2’		
LRC CHK	‘7’		
	‘7’		
END	CR		
	LF		

The explanation of exception codes:

Exception code	Explanation
1	Illegal data value: The data value received in the command message is not available for the AC drive.
2	Illegal data address: The data address received in the command message is not available for the AC motor drive.
3	Parameters are locked: parameters can't be changed
4	Parameters can't be changed during operation
10	Communication time-out.

09-05

~ Reserved

09-08

↗ **09-09** Response Delay Time

Factory Setting: 2.0

Settings 0.0~200.0ms

📖 This parameter is the response delay time after AC drive receives communication command as shown in the following.

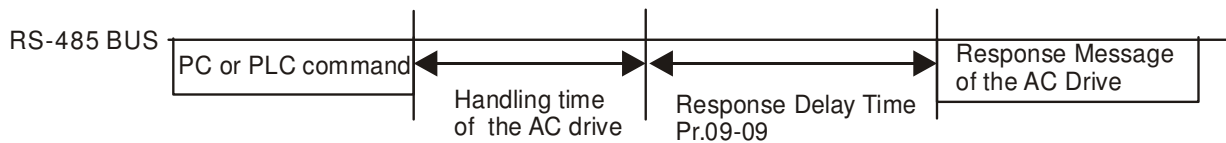

09-10 Main Frequency of the Communication

Factory Setting: 60.00

Settings 0.00~600.00Hz

📖 When Pr.00-20 is set to 1 (RS485 communication). The AC motor drive will save the last frequency command into Pr.09-10 when abnormal turn-off or momentary power loss. After reboots the power, it will regards the frequency set in Pr.09-10 if no new frequency command is inputted.

↗ **09-11** Block Transfer 1

↗ **09-12** Block Transfer 2

↗ **09-13** Block Transfer 3

↗ **09-14** Block Transfer 4

↗ **09-15** Block Transfer 5

↗ **09-16** Block Transfer 6

↗ **09-17** Block Transfer 7

↗ **09-18** Block Transfer 8

↗ **09-19** Block Transfer 9

↗ **09-20** Block Transfer 10

↗	09-21	Block Transfer 11
↗	09-22	Block Transfer 12
↗	09-23	Block Transfer 13
↗	09-24	Block Transfer 14
↗	09-25	Block Transfer 15
↗	09-26	Block Transfer 16

Factory Setting: 0.00

Settings 0.00~655.35

📖 There is a group of block transfer parameter available in the AC motor drive (Pr.09-11 to Pr.09-20). User can use them (Pr.09-11 to Pr.09-20) to save those parameters that you want to read.

09-27	~ Reserved
09-29	

09-30	Communication Decoding Method
--------------	-------------------------------

Factory Setting: 0

Settings 0: Decoding Method 1 (20xx)
1: Decoding Method 2 (60xx)

		Decoding Method 1	Decoding Method 2
Source of Operation Control	Digital Keypd	Digital keypad controls the drive action regardless decoding method 1 or 2.	
	External Terminal	External terminal controls the drive action regardless decoding method 1 or 2.	
	RS-485	Refer to address: 2000h~20FFh	Refer to address: 6000h ~ 60FFh
	CANopen	Refer to index: 2020-01h~2020-FFh	Refer to index:2060-01h ~ 2060-FFh
	Communication Card	Refer to address: 2000h ~ 20FFh	Refer to address: 6000h ~ 60FFh
	PLC	PLC commands the drive action regardless decoding method 1 or 2.	

09-31	Internal Communication Protocol
--------------	---------------------------------

Factory Setting: 0

Settings 0: Modbus 485

09-32	~ Reserved
09-33	

09-34	PLC PID
--------------	---------

Factory Setting: 0

Settings 0~65535

09-35 PLC Address

Factory Setting: 2

Settings 1~254

09-36 CANopen Slave Address

Factory Setting: 0

Settings 0: Disable
1~127

09-37 CANopen Speed

Factory Setting: 0

Settings 0: 1M
1: 500k
2: 250k
3: 125k
4: 100k (Delta only)
5: 50k

09-38 CANopen Frequency Gain

Factory Setting: 1.00

Settings 0.00~2.00

09-39 CANopen Warning Record

Factory Setting: 0

Settings bit 0: CANopen Guarding Time out
bit 1: CANopen Heartbeat Time out
bit 2: CANopen SYNC Time out
bit 3: CANopen SDO Time out
bit 4: CANopen SDO buffer overflow
bit 5: Can Bus Off
bit 6: Error protocol of CANOPEN

09-40 CANopen Decoding Method

Factory Setting: 1

Settings 0: Delta defined decoding method
1: CANopen Standard DS402 protocol

09-41 CANopen Status

Factory Setting: 0

Settings 0: Node Reset State
1: Com Reset State
2: Boot up State
3: Pre Operation State
4: Operation State
5: Stop State

09-42 CANopen Control Status

Factory Setting: Read Only

Settings 0: Not ready for use state
 1: Inhibit start state
 2: Ready to switch on state
 3: Switched on state
 4: Enable operation state
 7: Quick stop active state
 13: Err reaction activation state
 14: Error state

09-43 Reset CANopen Index

Factory Setting: 65535

Settings: bit0: reset address 20XX to 0.
 bit1: reset address 264X to 0
 bit2: reset address 26AX to 0
 bit3: reset address 60XX to 0

09-44 CANopen Error state

Factory Setting: Read Only

Settings 0~65535

09-44 Reserved**09-45** CANopen Master Function

Factory Setting: 0

Settings 0 : Disable
 1 : Enable

09-46 CANopen Master Address

Factory Setting: 100

Settings 1~127

10 PID Control

⚡ This parameter can be set during operation.

In this parameter group, ASR is the abbreviation for Adjust Speed Regulator and PG is the abbreviation for Pulse Generator.

10-00 Reserved

10-01 Encoder Pulse

Factory Setting: 600

Settings 1~20000

- 📖 A Pulse Generator (PG) or encoder is used as a sensor that provides a feedback signal of the motor speed. This parameter defines the number of pulses for each cycle of the PG control, i.e. the number of pulses for a cycle of A phase/B phase.
- 📖 This setting is also the encoder resolution. With the higher resolution, the speed control will be more accurate.
- 📖 An errotic input to Pr.10-00 may result drive over current, motor stall, PM motor magnetic pole origin detection error. If Pr.10-00 setting has changed, please trace the magnetic pole again, set Pr.05-00=4 (static test for PM motor magnetic pole and PG origin again).

10-02 Encoder Input Type Setting MI7=A; MI8=B

Factory Setting: 0

Settings 0: Disable

1: Phase A leads in a forward run command and phase B leads in a reverse run command

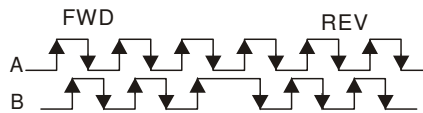

2: Phase B leads in a forward run command and phase A leads in a reverse run command

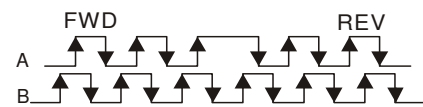

3: Phase A is a pulse input and phase B is a direction input. (L =reverse direction, H=forward direction)

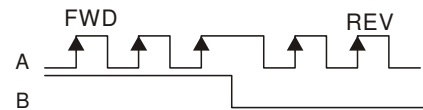

4: Phase A is a pulse input and phase B is a direction input. (L=forward direction, H=reverse direction)

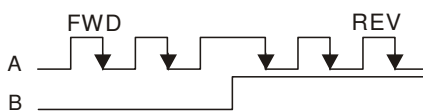

5: Single-phase input



10-03 Reserved✎ **10-04** Electrical Gear at Load Side A1✎ **10-05** Electrical Gear at Motor Side B1✎ **10-06** Electrical Gear at Load Side A2✎ **10-07** Electrical Gear at Motor Side B2

Factory Setting: 100

Settings 1~65535

📖 Parameters 10-04 to 10-07 can be used with the multi-function input terminal (set to 48) to switch to Pr.10-04~10-05 or Pr.10-06~10-07 as shown as follows

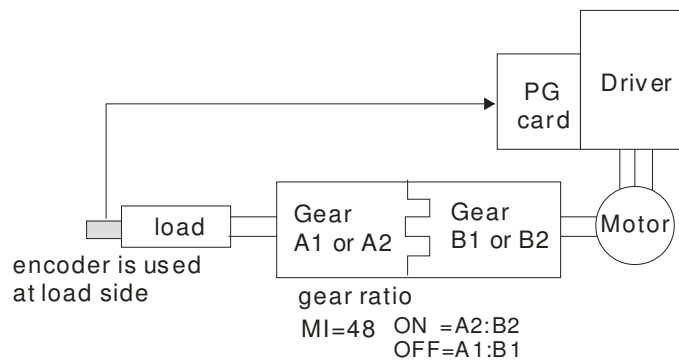
✎ **10-08** Treatment for Encoder Feedback Fault

Factory Setting: 2

Settings 0: Warn and keep operating
1: Warn and RAMP to stop
2: Warn and COAST to stop

✎ **10-09** Detection Time of Encoder Feedback Fault

Factory Setting: 1.0

Settings 0.0~10.0 sec
0: No function

📖 When encoder loss, encoder signal error, pulse signal setting error or signal error, if time exceeds the detection time for encoder feedback fault (Pr.10-09), the encoder signal error will occur. Refer to the Pr.10-08 for encoder feedback fault treatment.

✎ **10-10** Encoder Stall Level

Factory Setting: 115

Settings 0~120%
0: No function

📖 This parameter determines the maximum encoder feedback signal allowed before a fault occurs. (Max. output frequency Pr.01-00 =100%)

✎ **10-11** Detection Time of Encoder Stall

Factory Setting: 0.1

Settings 0.0~2.0 sec

➤ **10-12** Treatment for Encoder Stall

Factory Setting: 2

- Settings 0: Warn and keep operation
 1: Warn and ramp to stop
 2: Warn and coast to stop

📖 When the motor frequency exceeds Pr.10-10 setting and detection time exceeds Pr.10-11, it will operate as Pr.10-12 setting.

➤ **10-13** Encoder Slip Range

Factory Setting: 50

- Settings 0~50%
 0: Disable

➤ **10-14** Detection Time of Encoder Slip

Factory Setting: 0.5

- Settings 0.0~10.0 sec

➤ **10-15** Treatment for Encoder Stall and Slip Error

Factory Setting: 2

- Settings 0: Warn and keep operation
 1: Warn and ramp to stop
 2: Warn and coast to stop

📖 When the value of (rotation speed – motor frequency) exceeds Pr.10-13 setting, detection time exceeds Pr.10-14; it will start to accumulate time. If detection time exceeds Pr.10-14, the encoder feedback signal error will occur. Refer to Pr.10-15 encoder stall and slip error treatment.

10-16
 ~ Reserved
10-23

➤ **10-24** FOC&TQC Function Control

Factory Setting: 0

- Settings 0~65535

bit #	Description
0	ASR control at sensorless torque. 0:use PI as ASR; 1:use P as ASR
1~10	NA
11	Activate DC braking when executing zero torque command 0:ON , 1:OFF
12	FOC Sensorless mode, cross zero means speed goes from negative to positive or positive to negative (forward to reverse direction or reverse to forward direction). 0: determine by stator frequency , 1: determine by speed command
13~14	NA
15	Direction control at open loop status 0: Switch ON direction control 1: Switch OFF direction control

- ↗ **10-25** FOC Bandwidth of Speed Observer
 Factory Setting:40.0
 Settings 20.0~100.0Hz
 ⓘ Setting speed observer to higher bandwidth could shorten the speed response time but will create greater noise interference during the speed observation.
- ↗ **10-26** FOC Minimum Stator Frequency
 Factory Setting:2.0
 Settings 0.0~10.0%fN
 ⓘ This parameter is used to set the minimum level of stator frequency at operation status. This setting ensures the stability and accuracy of observer and avoid interferences from voltage, current and motor parameter.
- ↗ **10-27** FOC Low-pass Filter Time Constant
 Factory Setting:50
 Settings 0~1000ms
 ⓘ This parameter sets the low-pass filter time constant of a flux observer at start up. If the motor can not be activated during the high-speed operation, please lower the setting in this parameter.
- ↗ **10-28** FOC Gain of Excitation Current Rise Time
 Factory Setting:100
 Settings 0~100% Tr (Tr: rotor time constant)
 ⓘ This parameter sets the drive's excitation current rise time when activates at sensorless torque mode. When the drive's activation time is too long at torque mode, please adjust this parameter to a shorter time constant.
- ↗ **10-29** Top Limit of Frequency Deviation
 Factory Setting: 20.00
 Settings 0.00~100.00Hz
 ⓘ Pr.10-29 is for setting the maximum of frequency deviation.
- 10-30** Reserved
- ↗ **10-31** Observer Gain
 Factory Setting: 600
 Settings 0~65535
- ↗ **10-32** PM Sensorless Observer Bandwidth for High Speed Zone
 Factory Setting: 4.00
 Settings 0.00~600.00Hz
- ↗ **10-33** Reserved

↗	10-34	PM Sensorless Observer Low-pass Filter Gain	Factory Setting: 1.00
		Settings 0.00~655.35Hz	
↗	10-35	Reservevd	
↗	10-36	Reservevd	
↗	10-37	PM Sensorless Control Word	Factory Setting: 0000
		Settings 0000~FFFFh	
↗	10-38	Reservevd	
↗	10-39	Frequency Point when switch from I/F mode to PM Sensorless mode	Factory Setting: 20.00
		Settings 0.00~600.00Hz	
↗	10-40	Frequency Point when switch from PM Sensorless Observation mde to I/F mode	Factory Setting: 20.00
		Settings 0.00~600.00Hz	
↗	10-41	I/F mode, low pass-filter time	Factory Setting: 0.2
		Settings 0.0~6.0 sec	
↗	10-42	Initial Angle Detection Time	Factory Setting: 0
		Settings 0~10ms	

PM Sensorless Adjustment Procedure

- When using high frequency standstill VFD parameter tuning, use VFD software V1.48 or higher version to monitor adjustment procedure. To download VFD Software v1.45. go to:
<http://www.deltaww.com/services/DownloadCenter2.aspx?secID=8&pid=2&tid=0&CID=06&itemID=060101&typeID=1&dowloadID=&title=--%20%E8%AB%8B%E9%81%B8%E6%93%87%20--&dataType=8;&check=1&hl=zh-TW>
- Testing PM High Frequency Standstill VFD (calculation of Rs, Ld, Lg)
Procedures:
 - Set control mode as VF mode (Pr00-10=0, Pr00-11=0)
 - Output Frequency of Motor 1 (Pr01-01)
 - Output Voltage of Motor 1 (Pr01-02)
 - Induction Motor and Permanent Magnet Motor Selection (Pr05-33=1)
 - Full-load current of Permanent Magnet Motor(Pr05-34)
 - Set Moto Auto Tuning Pr 05-00 =13; High frequency and blocked rotor test for PM motor.
Then run the drive.
- Set control mode as PM sensorless Mode (Parameters 00-10=0, 00-11=6)

4. Set VFD Parameters

- ☑ Pr05-35 Rated Power of Permanent Magnet Motor
- ☑ Pr05-36 Rated speed of Permanent Magnet Motor
- ☑ Pr05-37 Pole number of Permanent Magnet Motor
- ☑ Pr05-38 Inertia of Permanent Magnet Motor

5. Set ASR Parameters

- ☑ Pr11-00 bit0=1: Auto tuning for ASR and APR
- ☑ Pr11-02 : ASR1/ASR2 Switch Frequency, it is recommended to set Pr10-39 higher than 10Hz.
- ☑ Pr11-03: ASR1 Low-speed Bandwidth and Pr11-03, ASR2 High-speed Bandwidth. Do not set Low-speed Bandwidth too high to avoid dissipation of the estimator.

6. Set speed estimator and speed control's parameter.

- ☑ Pr10-39 Frequency when switch from I/F Mode to PM sensorless mode.
- ☑ Pr10-32 PM Sensorless Observer Bandwidth for High Speed Zone

7. Zero-load test

- ☑ Refer to switch point procedure of I/F and FOC as shown in the image below.

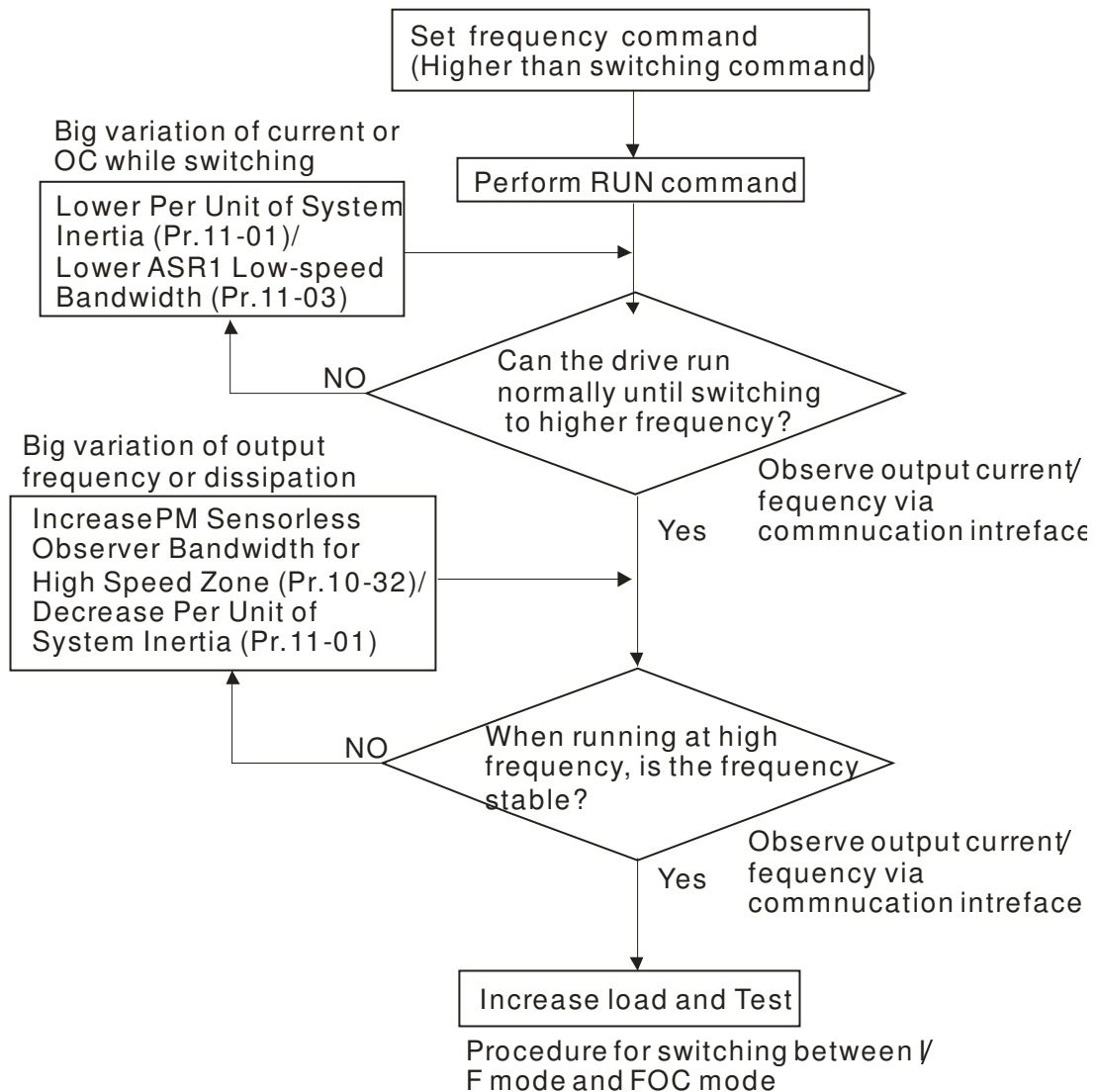

10-43	Reserved
~	
10-46	

10-47	The Filter Time of the Low Resolution ppr Encoder at Low Speed
	Factory Setting: 2
Settings	1~2000

10-48	The Switching Frequency of the Calculation Method for the Low Resolution ppr Encoder at Low Speed
	Factory Setting: 25.00
Settings	25.00~600.00Hz

11 Advanced Parameters

✎ This parameter can be set during operation.

In this parameter group, ASR is the abbreviation for Adjust Speed Regulator

11-00 System Control

Factory Setting: 0

- Settings
- 0: Auto tuning for ASR and APR
 - 1: Inertia estimate (only in FOC/PG mode)
 - 2: Zero servo
 - 3: Dead time compensation closed
 - 7: Selection to save or not save the frequency

- 📖 bit 0=0: Pr.11-06 to 11-11 will be valid and Pr.11-03~11-05 are invalid.
 bit 0=1: system will generate an ASR setting. At this moment, Pr.11-06~11-11 will be invalid and Pr.11-03~11-05 are valid.
- bit 1=0: no function.
 bit 1=1: Inertia estimate function is enabled. (Bit 1 setting would not activate the estimation process, please set Pr.05-00=12 to begin FOC/TQC Sensorless inertia estimating)
- bit 2=0: no function.
 bit 2=1: when frequency command is less than Fmin (Pr.01-07), it will use zero servo function.

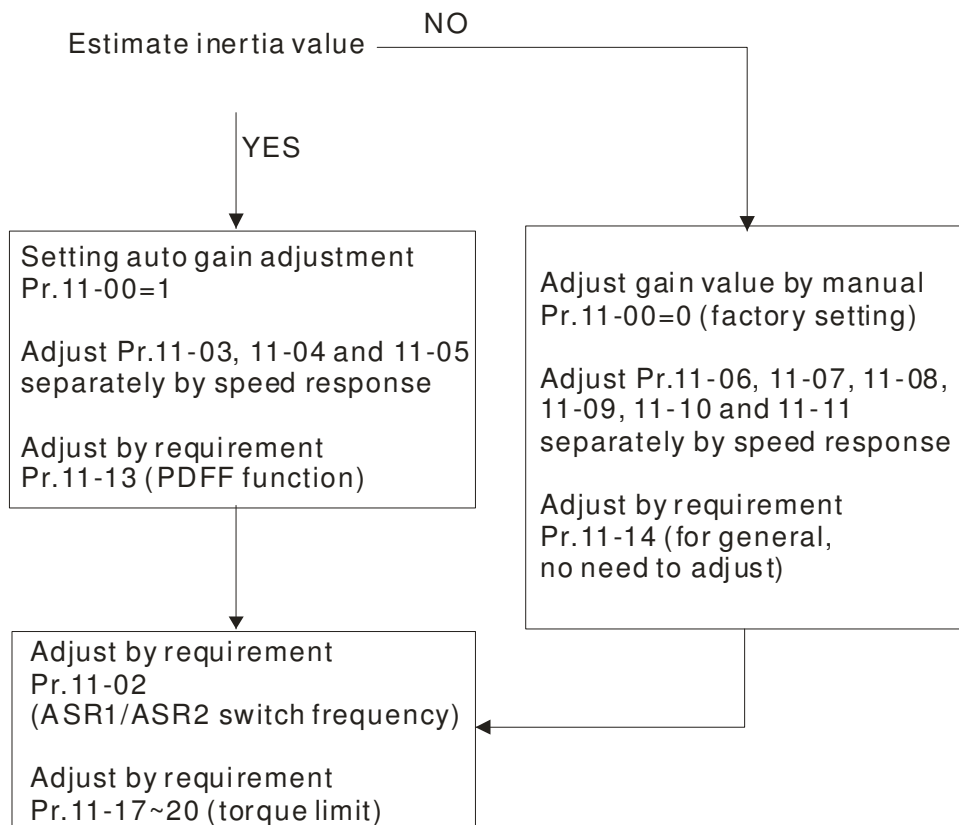

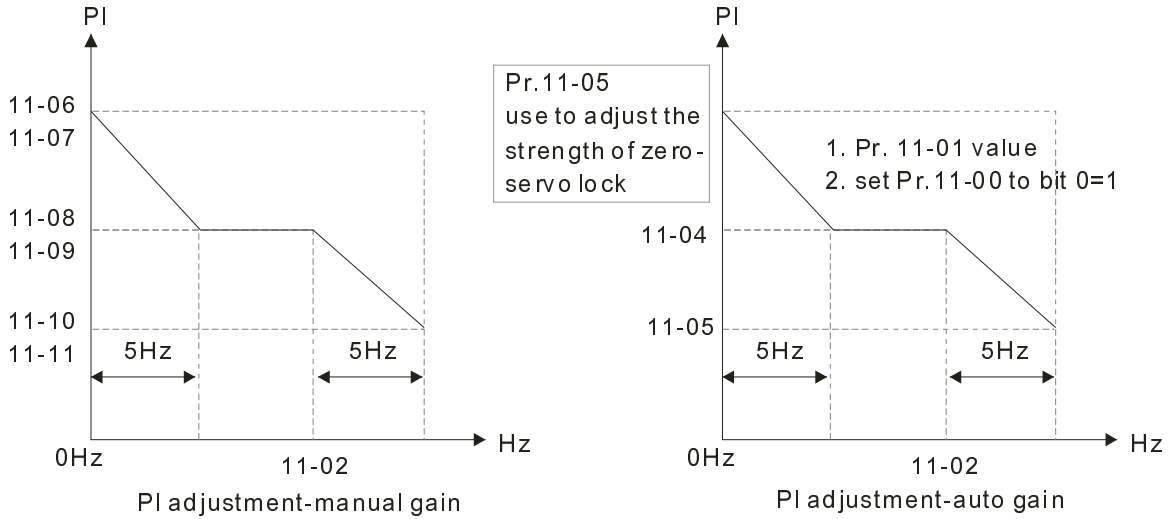

📖 bit 7=0: frequency is saved before power turns off. When power turns on again, the display frequency will be the memorized frequency.

bit 7=1: frequency is not saved before power turns off. When power turns ON again, the display frequency will be 0.00Hz.

➤ **11-01** Per Unit of System Inertia

Factory Setting: 400

Settings 1~65535 (256=1PU)

📖 To get the system inertia from Pr.11-01, user needs to set Pr.11-00 to bit1=1 and execute continuous forward/reverse running.

Unit of induction motor system inertia is 0.001kg-m²:

Power	Setting
1HP	2.3
2HP	4.3
3HP	8.3
5HP	14.8
7.5HP	26.0
10HP	35.8

The base value for induction motor system inertia is set by Pr.05-38 and the unit is in 0.001kg-m².

➤ **11-02** ASR1/ASR2 Switch Frequency

Factory Setting: 7.00

Settings 5.00~600.00Hz

0: no function

➤ **11-03** ASR1 Low-speed Bandwidth

Factory Setting: 10

Settings 1~40Hz (IM)/ 1~100Hz (PM)

➤ **11-04** ASR2 High-speed Bandwidth

Factory Setting: 10

Settings 1~40Hz (IM)/ 1~100Hz (PM)

➤ **11-05** Zero-speed Bandwidth

Factory Setting: 10

Settings 1~40Hz (IM)/ 1~100Hz (PM)

After estimating inertia and set Pr.11-00 to bit 0=1 (auto tuning), user can adjust parameters Pr.11-03, 11-04 and 11-05 separately by speed response. The larger number you set, the faster response you will get. Pr.11-02 is the switch frequency for low-speed/high-speed bandwidth.

➤	11-06 ASR (Auto Speed Regulation) control (P) 1	Factory Setting: 10
	Settings 0~40 Hz (IM)/ 1~100Hz (PM)	
➤	11-07 ASR (Auto Speed Regulation) control (I) 1	Factory Setting: 0.100
	Settings 0.000~10.000 sec	
➤	11-08 ASR (Auto Speed Regulation) control (PI) 2	Factory Setting: 10
	Settings 0~40 Hz (IM)/ 0~100Hz (PM)	
➤	11-09 ASR (Auto Speed Regulation) control (I) 2	Factory Setting: 0.100
	Settings 0.000~10.000 sec	
➤	11-10 ASR(Auto Speed Regulation) Control (P) of Zero Speed	Factory Setting: 10
	Settings 0~40 Hz (IM)/ 0~100Hz (PM)	
➤	11-11 ASR(Auto Speed Regulation) Control (I) of Zero Speed	Factory Setting: 0.100
	Settings 0.000~10.000 sec	
➤	11-12 Gain for ASR Speed Feed Forward	Factory Setting: 0
	Settings 0~100%	

This parameter is used to improve speed response.

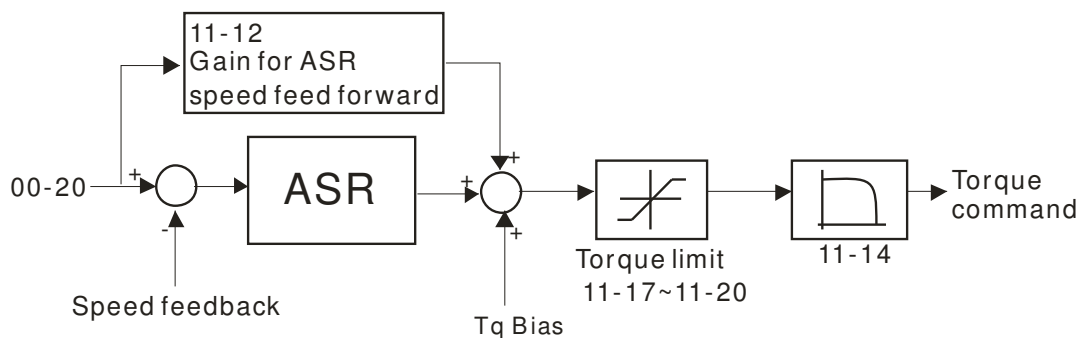

➤	11-13 PDFF Gain Value	Factory Setting: 30
	Settings 0~200%	

After finishing estimating and set Pr.11-00 to bit 0=1 (auto tuning), using Pr.11-13 to reduce overshoot. Please adjust PDFF gain value by actual situation.

📖 This parameter will be invalid when Pr.05-24 is set to 1.

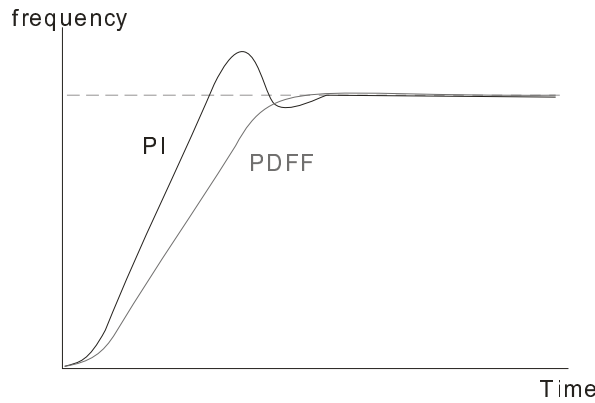

↗ **11-14** Low-pass Filter Time of ASR Output Factory Setting: 0.008
 Settings 0.000~0.350 sec

📖 It is used to set the filter time of ASR command.

↗ **11-15** Notch Filter Depth Factory Setting: 0
 Settings 0~20db

↗ **11-16** Notch Filter Frequency Factory Setting: 0.00
 Settings 0.00~200.00Hz

📖 This parameter is used to set resonance frequency of mechanical system. It can be used to suppress the resonance of mechanical system.

📖 The larger number you set Pr.11-15, the better suppression resonance function you will get.

📖 The notch filter frequency is the resonance of mechanical frequency.

↗ **11-17** Forward Motor Torque Limit

↗ **11-18** Forward Regenerative Torque Limit

↗ **11-19** Reverse Motor Torque Limit

↗ **11-20** Reverse Regenerative Torque Limit Factory Setting: 500
 Settings 0~500%

📖 The motor rated torque is 100%. The settings for Pr.11-17 to Pr.11-20 will compare with Pr.03-00=7, 8, 9, 10. The minimum of the comparison result will be torque limit.

📖 Calculation equation for motor rated torque:

$$\text{Motor rated torque} = T(N.M) = \frac{P(W)}{\omega(rad/s)} ; P(W) \text{ value} = \text{Pr.05-02};$$

$$\omega(rad/s) \text{ value} = \text{Pr.05-03} \cdot \frac{RPM \times 2\pi}{60} = rad/s$$

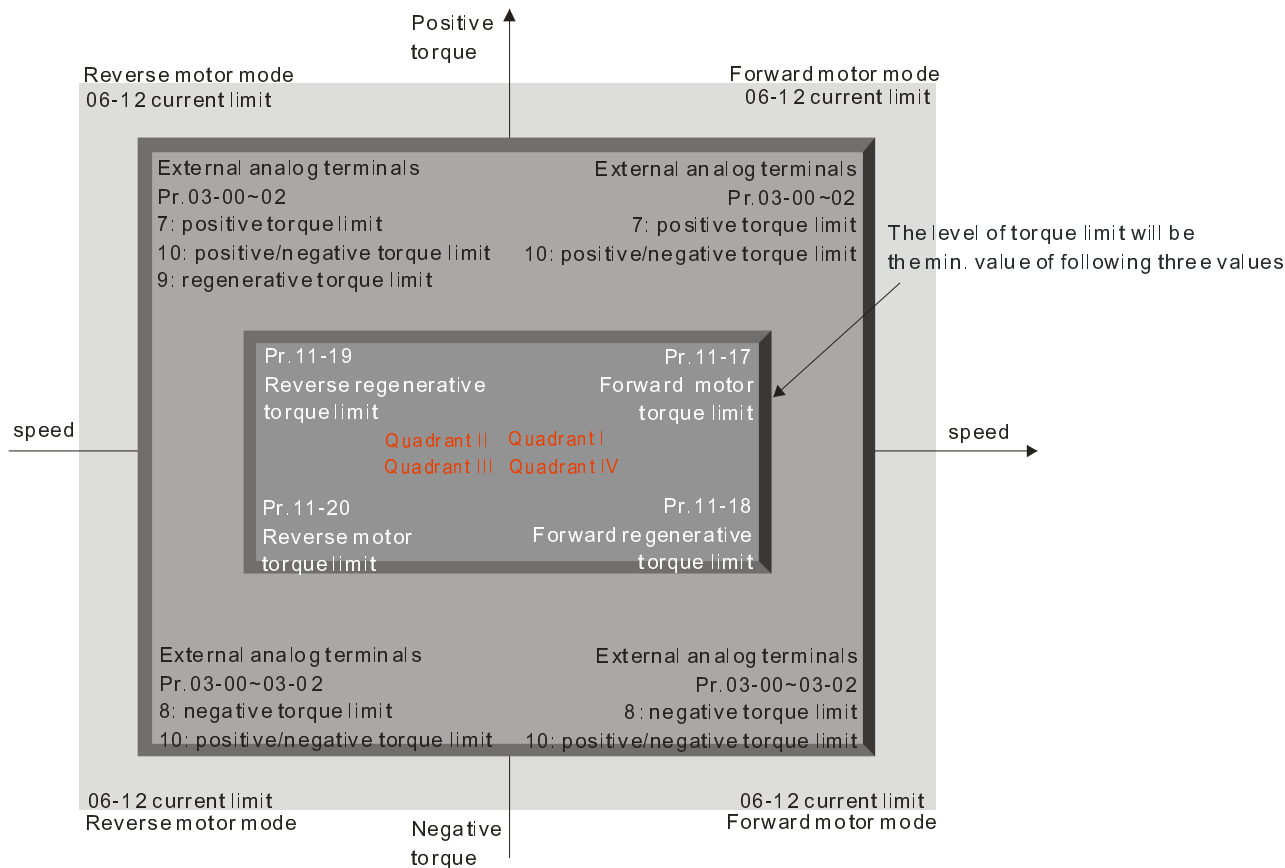

11-21 Gain Value of Flux Weakening Curve for Motor 1

Factory Setting: 90

Settings 0~200%

11-22 Gain Value of Flux Weakening Curve for Motor 2

Factory Setting: 90

Settings 0~200%

- Pr.11-21 and 11-22 are used to adjust the output voltage of flux weakening curve.
- For the spindle application, the adjustment method is
 1. It is used to adjust the output voltage when exceeding rated frequency.
 2. Monitor the output voltage
 3. Adjust Pr.11-21 (motor 1) or Pr.11-22 (motor 2) setting to make the output voltage reach motor rated voltage.
 4. The larger number it is set, the larger output voltage you will get.

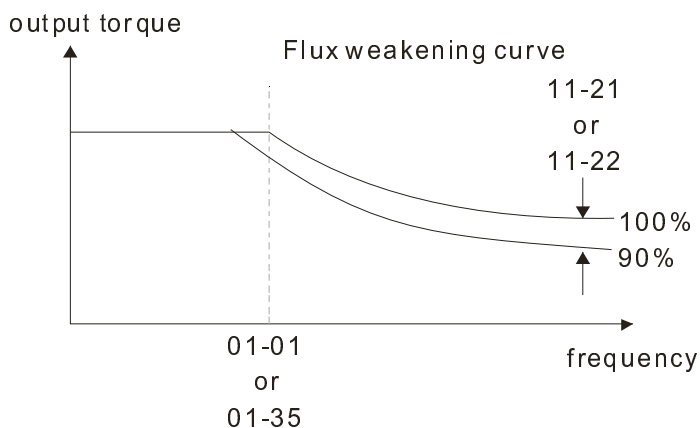

↖ **11-23** Speed Response of Flux Weakening Area

Factory Setting: 65

Settings 0: Disable
0~150%

📖 It is used to control the speed in the flux weakening area. The larger value is set in Pr.11-23, the faster acceleration/deceleration will generate. In general, it is not necessary to adjust this parameter.

11-24 Reserved

11-25 Reserved

11-26 Reserved

↖ **11-27** Max. Torque Command

Factory Setting: 100

Settings 0~500%

📖 The upper limit of torque command is 100%.

📖 Calculation equation for motor rated torque:

$$\text{motor rated torque: } T(N.M) = \frac{P(W)}{\omega(rad/s)}; P(W) \text{ value= Pr.05-02;}$$

$$\omega(rad/s) \text{ value= Pr.05-03} \cdot \frac{RPM \times 2\pi}{60} = rad/s$$

11-28 Source of Torque Offset

Factory Setting: 0

Settings 0: Disable
1: Analog input (Pr.03-00)
2: Torque offset setting (Pr.11-29)
3: Control by external terminal (by Pr.11-30 to Pr.11-32)

📖 This parameter is the source of torque offset.

📖 When it is set to 3, source of torque offset would determine Pr.11-30 to Pr.11-32 by

📖 When it is set to 3, the source of torque offset will regard Pr.11-30~11-32 by the multi-function input terminals (MI) setting (31, 32 or 33).

N.O. switch status: ON= contact closed, OFF= contact open

Pr. 11-32	Pr. 11-31	Pr. 11-30	Torque Offset
MI=33(High)	MI=32(Mid)	MI=31(Low)	
OFF	OFF	OFF	None
OFF	OFF	ON	Pr.11-30
OFF	ON	OFF	Pr.11-31
OFF	ON	ON	Pr.11-30+Pr.11-31
ON	OFF	OFF	Pr.11-32
ON	OFF	ON	Pr.11-30+Pr.11-32
ON	ON	OFF	Pr.11-31+Pr.11-32
ON	ON	ON	Pr.11-30+Pr.11-31+Pr.11-32

11-29 Torque Offset Setting

Factory Setting: 0.0

Settings 0.0~100.0%

📖 This parameter is torque offset. The motor rated torque is 100%.

📖 Calculation equation for motor rated torque:

$$\text{motor rated torque: } T(N.M) = \frac{P(W)}{\omega(rad/s)}; P(W) \text{ value= Pr.05-02;}$$

$$\omega(rad/s) \text{ value= Pr.05-03} \cdot \frac{RPM \times 2\pi}{60} = rad/s$$

11-30 High Torque Offset

Factory Setting: 30.0

Settings 0.0~100.0%

11-31 Middle Torque Offset

Factory Setting: 20.0

Settings 0.0~100.0%

11-32 Low Torque Offset

Factory Setting: 10.0

Settings 0.0~100.0%

📖 When it is set to 3, the source of torque offset will regard Pr.11-30, Pr.11-31 and Pr.11-32 by the multi-function input terminals setting (31, 32 or 33). The motor rated torque is 100%.

📖 Calculation equation for motor rated torque:

$$\text{motor rated torque: } T(N.M) = \frac{P(W)}{\omega(rad/s)}; P(W) \text{ value= Pr.05-02;}$$

$$\omega(rad/s) \text{ value= Pr.05-03} \cdot \frac{RPM \times 2\pi}{60} = rad/s$$

11-33 Source of Torque Command

Factory Setting: 0

Settings 0: Digital Keypad (Pr.11-34)
 1: RS485 serial communication
 2: Analog signal (Pr.03-00)
 3: CANopen

📖 When Pr.11-33 is set to 0, torque command can be set in Pr.11-34.

📖 When Pr.11-33 is set to 1 or 2, Pr.11-34 would only display the torque command

11-34 Torque Command

Factory Setting: 0.0

Settings -100.0~100.0%(Pr.11-27=100%)

📖 This parameter is for the torque command. When Pr.11-27 is set to 250% and Pr.11-34 is set to 100%, actual torque command=250X100%=250% motor rated torque.

📖 The drive will save the setting to the record before power turns off.

11-35 Low-pass Filter Time of Torque Command

Factory Setting: 0.000

Settings 0.000~1.000 sec

When the setting is too long, the control will be stable but the control response will be delay. When the setting is too short, the response will be quickly but the control maybe unstable. User can adjust the setting by the control and response situation.

11-36 Speed Limit Selection

Factory Setting: 0

Settings 0: Set by Pr.11-37 (Forward speed limit) and Pr.11-38 (Reverse speed limit)
 1: Set by Pr.11-37,11-38 and Pr.00-20 (Source of Master Frequency Command)
 2: Set by Pr.00-20 (Source of Master Frequency Command).

Speed limit function: in TQCPG, when the motor speed is accelerated to speed limit value (Pr.11-36, 11-37 and 11-38), it will switch to speed control mode to stop acceleration.
 When the torque is positive direction, speed limit is positive direction. When the torque is negative direction, speed limit is negative direction.

Pr. 11-36=0
 Forward/reverse running speed are limited by Pr. 11-37 and Pr. 11-38.

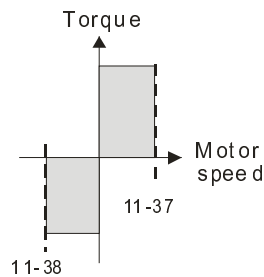

Pr. 11-36=2
 Forward/reverse running speed are limited by Pr.00-20.

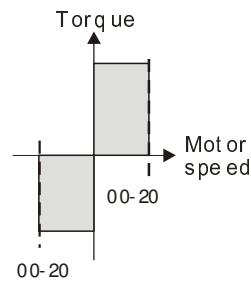

Pr. 11-36=1
 When torque is positive, forward running speed is limited by Pr.00-20; reverse running speed is limited by Pr.11-38.

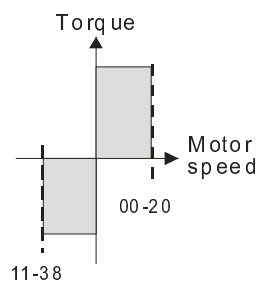

Pr. 11-36=1
 When torque is negative, forward running speed is limited by Pr.11-37; reverse running speed is limited by Pr.00-20.

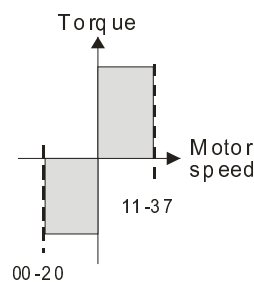

↖ **11-37** Forward Speed Limit (torque mode)

Factory Setting: 10

Settings 0~120%

↖ **11-38** Reverse Speed Limit (torque mode)

Factory Setting: 10

Settings 0~120%

📖 These parameters are used in the torque mode to limit the running direction and opposite direction. (Pr.01-00 max. output frequency=100%)

11-39 Zero Torque Command Mode

Factory Setting: 0

Settings 0: Torque mode

1: Speed mode

📖 This parameter defines the torque command mode at 0% of torque output. When Pr.11-39 is set as 0 (the torque mode), if torque command is 0%, the motor will produce excitation current but no torque current. When Pr.11-39 is set as 1 (the speed mode), if torque command is 0%, the AC motor drive can still produce torque current through speed controller to prevent motor race and the drive will also automatically adjust the speed to 0 when the speed command is not equal to 0.

11-40

~ Reserved

11-41

↖ **11-42** System Control 2

Factory Setting: 0

Settings 0~65535

10-2 Adjustment & Application

Swing Function

The C200 will accomplish the Texturing machine function via enable the built-in “Texturing machine function”. The method is as below:

- Step 1: Set PLC as Disable.
- Step 2: Set Pr00-02 = 2.
- Step 3: Then, set Pr00-02=100
- Step 4: Set PLC in PLC RUN mode.

04- MULTI-SPEED

- ◆ 50 PLC Buffer 0
- 51 PLC Buffer 1
- 52 PLC Buffer 2

Before enabling the built-in PLC Swing Vibration Program

04- MULTI-SPEED

- ◆ 50 Pre-Frequency
- 51 Keep Pre-Freq T
- 52 PLC Buffer 2

After enabling the built-in PLC Swing Vibration Program

Description of the Swing Function Parameters







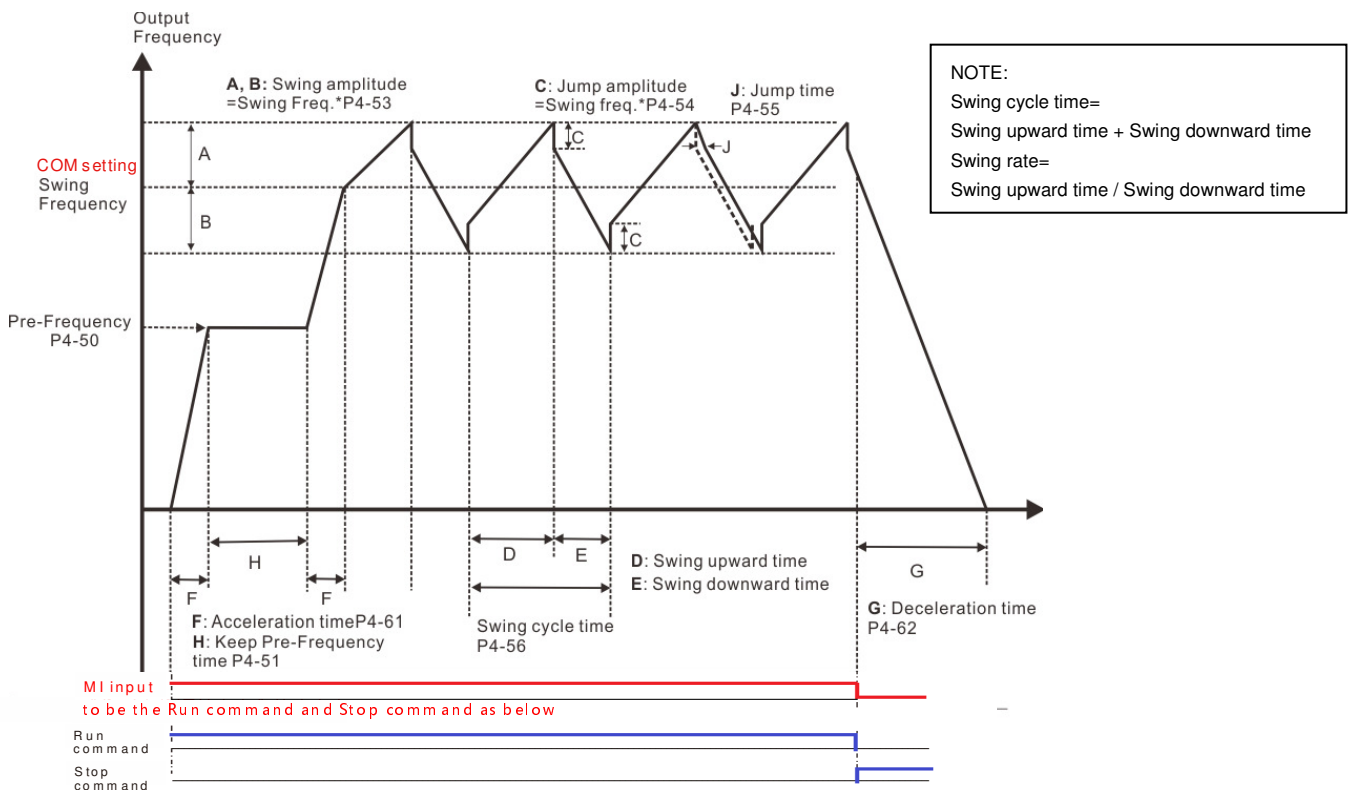

The Swing function parameters are suitable for textile industry, synthetic fiber fabricating, cable reeling, and transverse movement.

The following process shows how the Swing function work.

1. Start to run and reach the Pre-Frequency (P4-50) according to the system acceleration time (P4-61).
2. Running at the Pre-Frequency for Keep Pre-Freq Time (P4-51).
3. After, accelerating to Swing frequency and start to operate Swing function according to P4-53 Swing amplitude (%), P4-54 Jump amplitude (%), P4-55 Jump time, P4-56 Swing Cycle Time and P4-57 Swing Rate. To operate with cycle and cycle until received a Stop command. To stop the motor according to the system deceleration time (P4-62).

The swing frequency should be set by COM.



04-50 Pre-Frequency	Factory Setting: 3000
Settings 0.00~600.00Hz	
04-51 Keep Pre-Freq. Time	Factory Setting: 3.0
Settings 0.1~6000.0 sec.	
<p> The operating frequency and time before start to operate "Swing function".</p>	
04-53 Swing Amplitude (%)	Factory Setting: 10.0
Settings 0.0~50.0%	
<p> Maximum swing operate freq.=Swing freq. + Swing freq. x Pr.4-53 Minimum swing operate freq. = Swing freq. - Swing freq. x Pr.4-53</p> <p> The swing frequency is limited by the output Frequency Upper Limit and Output Frequency Lower Limit. When the frequency is over upper limit or lowers than lower limit frequency, the swing frequency will be recalculated by the upper and lower limit frequency.</p>	
04-54 Jump Amplitude (%)	Factory Setting: 2.0
Settings 0.0~50.0%	
<p> Swing jumping frequency = Swing frequency x Pr.4-54</p> <p> An over voltage or over torque might happened if the Pr.04-54 setting is too big. The setting is limited to be less than 30% of the swing amplitude.</p>	
04-55 Jump Time	Factory Setting: 0.00
Settings 0.00~0.10 sec.	
04-56 Swing Cycle Time	Factory Setting: 10.0
Settings 0.00~100.00 sec.	
<p> Swing cycle time = Swing upward time + Swing downward time</p>	
04-57 Swing Rate	Factory Setting: 1.00
Settings 0.01~100.0	
<p> This parameter is to set up the ratio between Swing upward and downward time.</p> <p> Swing rate = Swing upward time / Swing downward time</p>	
04-58 Enable Random Swing	Factory Setting: 0
Settings 0: Disable 1: Enable	
<p> To avoid accumulation of fibers and to provide more variety on swing function. When Pr.04-58=1,</p>	

the turbulence slope of the swing vibration will go up and down in an irregular way. But the output frequency will not go beyond the maximum swing operate frequency and minimum swing operate frequency.

📖 When the Pr.04-58=1, the Pr.04-57 setting is disabled.

↗ **04-59** Maximum Random Rate

Factory Setting: 1.00

Settings 0.01~100.00

↗ **04-60** Minimum Random Rate

Factory Setting: 1.00

Settings 0.01~100.00

📖 Maximum random rate \geq Swing upward time / Swing downward time

📖 Minimum random rate \leq Swing upward time / Swing downward time

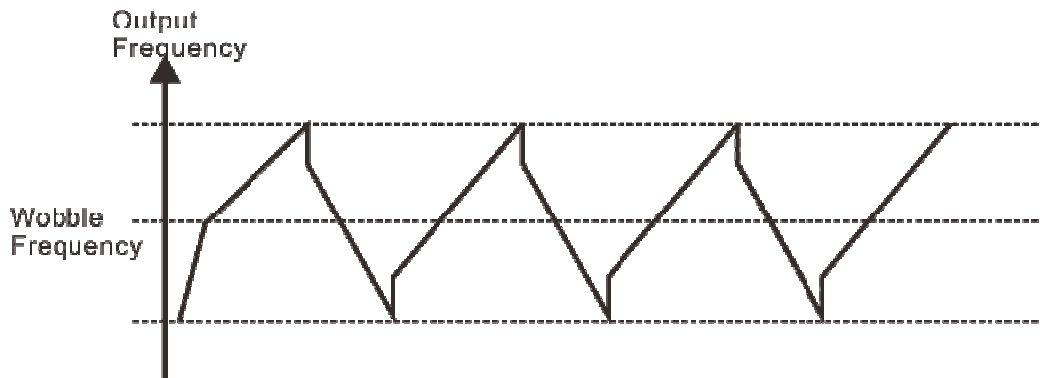

↗ **04-61** Start Run Acceleration Time

Factory Setting: 10.00

Settings 0.00~600.00

↗ **04-62** Start Run Deceleration Time

Factory Setting: 10.00

Settings 0.00~600.00

Chapter 11 Warning Codes

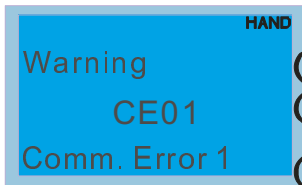

- ① Display error signal
- ② Abbreviate error code.
The code is displayed as shown on KPC-CE01
- ③ Display error description

ID No.	KPE-LE02 Display	LCM Display	Descriptions
1	CE01	Warning CE01 Comm. Error 1	Modbus function code error
2	CE02	Warning CE02 Comm. Error 2	Address of Modbus data is error
3	CE03	Warning CE03 Comm. Error 3	Modbus data error
4	CE04	Warning CE04 Comm. Error 4	Modbus communication error
5	CE 10	Warning CE10 Comm. Error 10	Modbus transmission time-out
6	CP 10	Warning CP10 Keypad time out	Keypad transmission time-out
7	SE 1	Warning SE1 Save Error 1	Keypad COPY error 1 Keypad simulation error, including communication delays, communication error (keypad received error FF86) and parameter value error.
8	SE2	Warning SE2 Save Error 2	Keypad COPY error 2 Keypad simulation done, parameter write error
9	oH 1	Warning oH1 Over heat 1 warn	IGBT over-heating warning

ID No.	KPE-LE02 Display	LCM Display	Descriptions
10	oH2	<div style="border: 1px solid black; padding: 2px;"> HAND Warning oH2 Over heat 2 warn </div>	Capacity over-heating warning
11	PId	<div style="border: 1px solid black; padding: 2px;"> HAND Warning PID PID FBK Error </div>	PID feedback error
12	AnL	<div style="border: 1px solid black; padding: 2px;"> HAND Warning AnL Analog loss </div>	A ACI signal error When Pr03-19 is set to 1 and 2.
13	uI	<div style="border: 1px solid black; padding: 2px;"> HAND Warning uC Under Current </div>	Low current
14	AUE	<div style="border: 1px solid black; padding: 2px;"> HAND Warning AUE Auto-tune error </div>	Auto tuning error
15	PGFb	<div style="border: 1px solid black; padding: 2px;"> HAND Warning PGFB PG FBK Warn </div>	PG feedback error
16	PGL	<div style="border: 1px solid black; padding: 2px;"> HAND Warning PGL PG Loss Warn </div>	PG feedback loss
17	oSPd	<div style="border: 1px solid black; padding: 2px;"> HAND Warning oSPD Over Speed Warn </div>	Over-speed warning
18	dAvE	<div style="border: 1px solid black; padding: 2px;"> HAND Warning DAve Deviation Warn </div>	Over speed deviation warning
19	PHL	<div style="border: 1px solid black; padding: 2px;"> HAND Warning PHL Phase Loss </div>	Phase loss
20	ot 1	<div style="border: 1px solid black; padding: 2px;"> HAND Warning ot1 Over Torque 1 </div>	Over torque 1
21	ot 2	<div style="border: 1px solid black; padding: 2px;"> HAND Warning ot2 Over Torque 2 </div>	Over torque 2

ID No.	KPE-LE02 Display	LCM Display	Descriptions
22	oH3		Motor over-heating
23	c.c		CC warning
24	oSL		Over slip
25	tUn		Auto tuning processing
26	AHSP		Auto/Hand on switching STOP
27	PGrE		PG Ref input error
28	OPHL		Output phase loss
29	Swcc		Software CC occurred
30	SE3		Keypad COPY error 3 Keypad copy between different power range drive
36	CGdn		CAN guarding time-out 1
37	CHbn		CAN guarding time-out 2
38	CSYn		CAN synchrony time-out

ID No.	KPE-LE02 Display	LCM Display	Descriptions
39	CbFn	Warning CbFn Can Bus Off	CAN bus off
40	CIdn	Warning CIdn CAN/S Idx exceed	CAN index error
41	CAdn	Warning CAdn CAN/S Adres set	CAN station address error
42	CFrn	Warning CFrn CAN/S FRAM fail	CAN memory error
43	CSdn	Warning CSdn SDO T-out	CAN SDO transmission time-out
44	CSbn	Warning CSbn Buf Overflow	CAN SDO received register overflow
45	Cbtn	Warning Cbtn Boot up fault	CAN boot up error
46	CPtn	Warning CPtn Error Protocol	CAN format error
47	PLrA	Warning PLra RTC Adjust	Adjust RTC
48	PLic	Warning PLiC Inner COM Error	InnerCOM Error
49	PLrt	Warning PLrt Keypad RTC TOut	Keypad RTC time out
50	PLod	Warning PLod Opposite Defect	Opposite data defect

ID No.	KPE-LE02 Display	LCM Display	Descriptions
51	PLSu	Warning PLSv Save mem defect	Saving memory is incorrect
52	PLdA	Warning PLdA Data defect	Data code defect
53	PLFn	Warning PLFn Function defect	Function code defect
54	PLor	Warning PLor Buf overflow	Over the buffer of PLC
55	PLFF	Warning PLFF Function defect	Function code defect
56	PLSn	Warning PLSn Check sum error	Checksum error
57	PLEd	Warning PLEd No end command	PLC no end command
58	PLCr	Warning PLCr PLC MCR error	PLC MCR error
59	PLdF	Warning PLdF Download fail	PLC download fail
60	PLSF	Warning PLSF Scane time fail	PLC scan time fail
61	PC9d	Warning PCGd CAN/M Guard err	PLC CAN Master CANopen Guarding Tome Out
62	PCbF	Warning PCbF CAN/M bus off	PLC CAN Master Can Bus off

ID No.	KPE-LE02 Display	LCM Display	Descriptions
63	PCnL	Warning PCnL CAN/M Node Lack	PLC CAN Master node lack
64	PCct	Warning PCct CAN/M Cycle Time	PLC CAN Master cycle time
65	PCSF	Warning PCSF CAN/M SDO over	PLC CAN Master TX buffer overflow SDO, NMT, GUD
66	PCSD	Warning PCSD CAN/M Sdo Tout	PLC CAN Master SDO transfer time out
67	PCAd	Warning PCAd CAN/M Address set	CAN Master Slave address set fail
70	EC id	Warning ECid ExCom ID failed	Duplicate MAC ID error node address setting error
71	ECLv	Warning ECLv ExCom pwr loss	Low voltage of communication card
72	ECtt	Warning ECtt ExCom Test Mode	Communication card in test mode
73	ECbF	Warning ECbF ExCom Bus off	DeviceNet bus-off
74	ECnP	Warning ECnP ExCom No power	DeviceNet no power
75	ECFF	Warning ECFF ExCom Facy def	Factory default setting error
76	ECiF	Warning ECiF ExCom Inner err	Serious internal error

ID No.	KPE-LE02 Display	LCM Display	Descriptions
77	EC 10	Warning EC10 ExCom IONet brk	IO connection break off
78	ECPP	Warning ECPP ExCom Pr data	Profibus parameter data error
79	ECPi	Warning ECPi ExCom Conf data	Profibus configuration data error
80	ECEF	Warning ECEF ExCom Link fail	Ethernet Link fail
81	ECto	Warning ECto ExCom Inr T-out	Communication time-out for communication card and drive
82	ECCS	Warning ECCS ExCom Inr CRC	Check sum error for Communication card and drive
83	ECrF	Warning ECrF ExCom Rtn def	Communication card returns to default setting
84	EC00	Warning EC00 ExCom MTCP over	Modbus TCP exceed maximum communication value
85	EC01	Warning EC01 ExCom EIP over	EtherNet/IP exceed maximum communication value
86	ECiP	Warning ECiP ExCom IP fail	IP fail
87	EC3F	Warning EC3F ExCom Mail fail	Mail fail
88	ECby	Warning ECby ExCom Busy	Communication card busy

ID No.	KPE-LE02 Display	LCM Display	Descriptions
90	CPLP	<div style="border: 1px solid black; padding: 2px;"> HAND Warning CPLP Copy PLC Pass Wd </div>	Copy PLC password error
91	CPL0	<div style="border: 1px solid black; padding: 2px;"> HAND Warning CPL0 Copy PLC Mode Rd </div>	Copy PLC Read mode error
92	CPL1	<div style="border: 1px solid black; padding: 2px;"> HAND Warning CPL1 Copy PLC Mode Wt </div>	Copy PLC Write mode error
93	CPLv	<div style="border: 1px solid black; padding: 2px;"> HAND Warning CPLv Copy PLC Version </div>	Copy PLC Version error
94	CPLS	<div style="border: 1px solid black; padding: 2px;"> HAND Warning CPLS Copy PLC Size </div>	Copy PLC Capacity size error
95	CPLF	<div style="border: 1px solid black; padding: 2px;"> HAND Warning CPLF Copy PLC Func </div>	Copy PLC must PLC function disable
96	CPLT	<div style="border: 1px solid black; padding: 2px;"> HAND Warning CPLT Copy PLC Time Out </div>	Copy PLC time out
101	ictn	<div style="border: 1px solid black; padding: 2px;"> HAND Warning ictn InrCOM Time Out </div>	InnerCOM time out fail

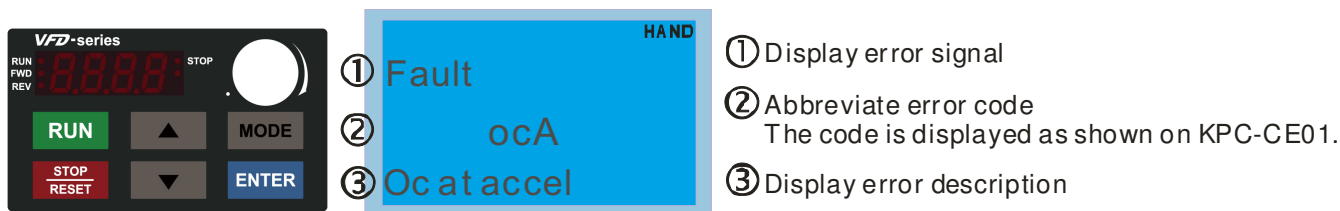

Chapter 12 Fault Codes and Descriptions



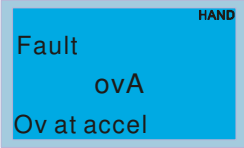
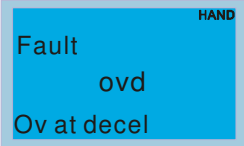
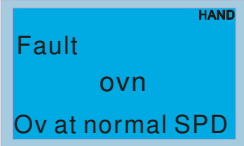
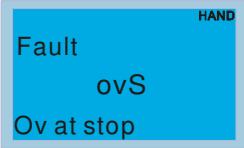
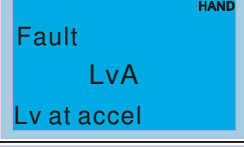
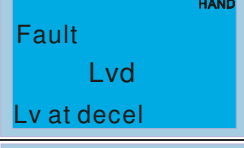
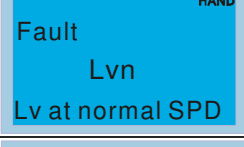
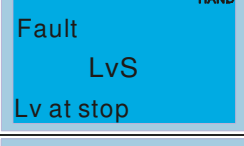
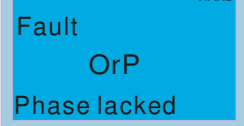

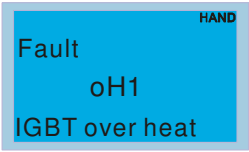
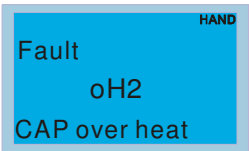
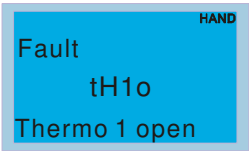
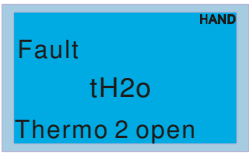
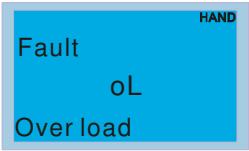
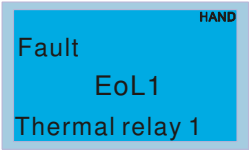
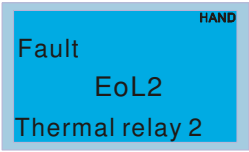
ID No.	KPE-LE02 Display	LCM Display	Descriptions
1	ocA		Over-current during acceleration (Output current exceeds triple rated current during acceleration.) Corrective Actions: <ol style="list-style-type: none"> Short-circuit at motor output: Check for possible poor insulation at the output lines. Acceleration Time too short: Increase the Acceleration Time. AC motor drive output power is too small: Replace the AC motor drive with the next higher power model.
2	ocd		Over-current during deceleration (Output current exceeds triple rated current during deceleration.) Corrective Actions: <ol style="list-style-type: none"> Short-circuit at motor output: Check for possible poor insulation at the output line. Deceleration Time too short: Increase the Deceleration Time. AC motor drive output power is too small: Replace the AC motor drive with the next higher power model.
3	ocn		Over-current during steady state operation (Output current exceeds triple rated current during constant speed.) Corrective Actions: <ol style="list-style-type: none"> Short-circuit at motor output: Check for possible poor insulation at the output line. Sudden increase in motor loading: Check for possible motor stall. AC motor drive output power is too small: Replace the AC motor drive with the next higher power model.
4	GFF		Corrective Actions: When (one of) the output terminal(s) is grounded, short circuit current is more than 75% of AC motor drive rated current, the AC motor drive power module may be damaged. NOTE: The short circuit protection is provided for AC motor drive protection, not for protection of the user. <ol style="list-style-type: none"> Check the wiring connections between the AC motor drive and motor for possible short circuits, also to ground. Check whether the IGBT power module is damaged. Check for possible poor insulation at the output line.
5	occ		Short-circuit is detected between upper bridge and lower bridge of the IGBT module. Corrective Actions: Return to the factory
6	ocS		Over-current at stop Corrective Actions: Return to the factory

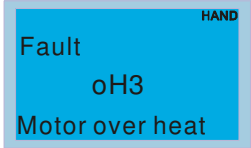
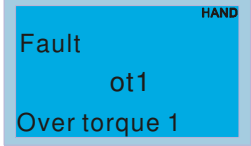
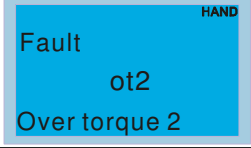

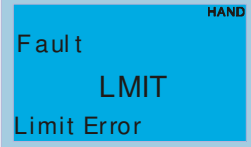
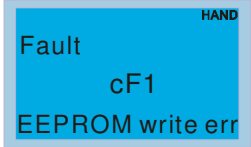
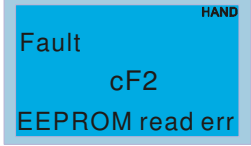
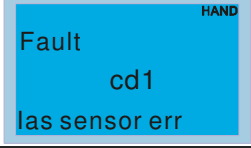
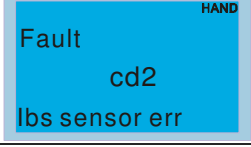
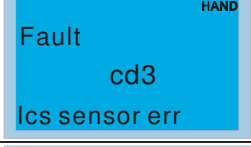
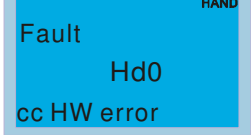

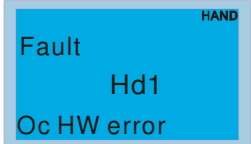
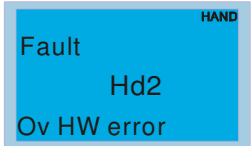
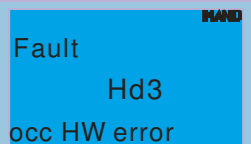
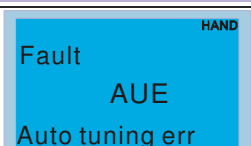
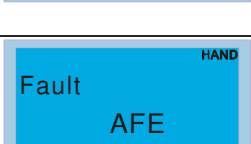
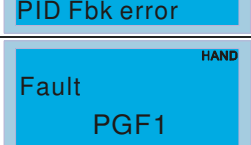
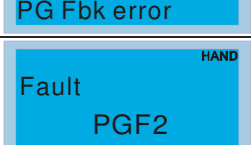
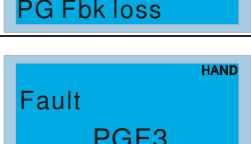
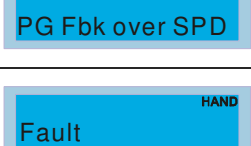
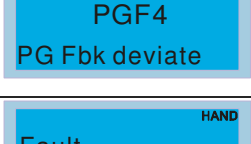
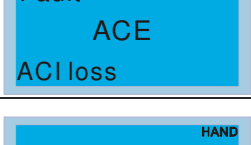
ID No.	KPE-LE02 Display	LCM Display	Descriptions
7	ovA		<p>DC BUS over-voltage during acceleration (230V: DC 450V; 460V: DC 900V)</p> <p>Corrective Actions:</p> <ol style="list-style-type: none"> 1. Check if the input voltage falls within the rated AC motor drive input voltage range. 2. Check for possible voltage transients. 3. If DC BUS over-voltage due to regenerative voltage, please increase the Deceleration Time or add an optional brake resistor.
8	ovd		<p>DC BUS over-voltage during deceleration (230V: DC 450V; 460V: DC 900V)</p> <p>Corrective Actions:</p> <ol style="list-style-type: none"> 1. Check if the input voltage falls within the rated AC motor drive input voltage range. 2. Check for possible voltage transients. 3. If DC BUS over-voltage due to regenerative voltage, please increase the Deceleration Time or add an optional brake resistor.
9	ovn		<p>DC BUS over-voltage during constant speed (230V: DC 450V; 460V: DC 900V)</p> <p>Corrective Actions:</p> <ol style="list-style-type: none"> 1. Check if the input voltage falls within the rated AC motor drive input voltage range. 2. Check for possible voltage transients. 3. If DC BUS over-voltage due to regenerative voltage, please increase the Deceleration Time or add an optional brake resistor.
10	ovS		<p>DC BUS over-voltage at stop</p> <p>Corrective Actions:</p> <ol style="list-style-type: none"> 1. Check if the input voltage falls within the rated AC motor drive input voltage range. 2. Check for possible voltage transients.
11	LvA		<p>DC BUS voltage is less than Pr.06-00 during acceleration.</p> <p>Corrective Actions:</p> <ol style="list-style-type: none"> 1. Check if the input voltage is normal 2. Check for possible sudden load
12	Lvd		<p>DC BUS voltage is less than Pr.06-00 during deceleration.</p> <p>Corrective Actions:</p> <ol style="list-style-type: none"> 1. Check if the input voltage is normal 2. Check for possible sudden load
13	Lvn		<p>DC BUS voltage is less than Pr.06-00 during constant speed.</p> <p>Corrective Actions:</p> <ol style="list-style-type: none"> 1. Check if the input voltage is normal 2. Check for possible sudden load
14	LvS		<p>Low voltage at stop</p> <p>Corrective Actions:</p> <ol style="list-style-type: none"> 1. Check if the input voltage is normal 2. Check for possible sudden load
15	orP		<p>Phase Loss</p> <p>Corrective Actions:</p> <p>Check Power Source Input if all 3 input phases are connected without loose contacts.</p>

ID No.	KPE-LE02 Display	LCM Display	Descriptions
16	oH1		<p>IGBT overheating IGBT temperature exceeds protection level 40 to100HP: 100 °C</p> <p>Corrective Actions:</p> <ol style="list-style-type: none"> 1. Ensure that the ambient temperature falls within the specified temperature range. 2. Make sure that the ventilation holes are not obstructed. 3. Remove any foreign objects from the heatsinks and check for possible dirty heat sink fins. 4. Check the fan and clean it. 5. Provide enough spacing for adequate ventilation.
17	oH2		<p>Heatsink overheating Capacitance temperature exceeds cause heatsink overheating.</p> <p>Corrective Actions:</p> <ol style="list-style-type: none"> 1. Ensure that the ambient temperature falls within the specified temperature range. 2. Make sure heat sink is not obstructed. Check if the fan is operating 3. Check if there is enough ventilation clearance for AC motor drive.
18	tH1o		<p>Motor 1 overload</p> <p>Corrective Actions:</p> <ol style="list-style-type: none"> 1. Check whether the motor is overloaded. 2. Check whether the rated current of motor (Pr.05-01) is suitable 3. Take the next higher power AC motor drive model.
19	tH2o		<p>Motor overheating The AC motor drive detects that the internal temperature exceeds Pr.06-30 (PTC level)</p> <p>Corrective Actions:</p> <ol style="list-style-type: none"> 1. Make sure that the motor is not obstructed. 2. Ensure that the ambient temperature falls within the specified temperature range. 3. Take the next higher power AC motor drive model.
21	oL		<p>Overload The AC motor drive detects excessive drive output current. NOTE: The AC motor drive can withstand up to 150% of the rated current for a maximum of 60 seconds.</p> <p>Corrective Actions:</p> <ol style="list-style-type: none"> 1. Check whether the motor is overloaded. 2. Take the next higher power AC motor drive model.
22	EoL1		<p>Electronic Thermal Relay 1 Protection</p> <p>Corrective Actions:</p> <ol style="list-style-type: none"> 1. Check whether the motor is overloaded. 2. Check whether motor rated current setting (Pr.05-01) is suitable 3. Check electronic thermal relay function 4. Take the next higher power AC motor drive model.
23	EoL2		<p>Electronic Thermal Relay 2 Protection</p> <p>Corrective Actions:</p> <ol style="list-style-type: none"> 1. Check whether the motor is overloaded. 2. Check whether motor rated current setting (Pr.05-01) is suitable 3. Check electronic thermal relay function 4. Take the next higher power AC motor drive model.

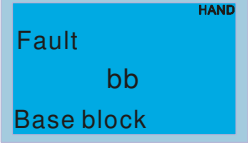
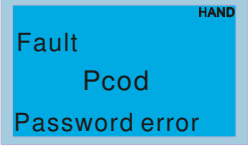
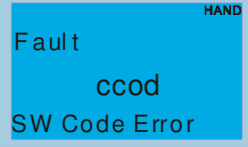
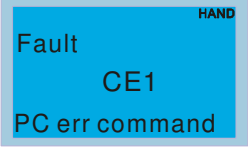
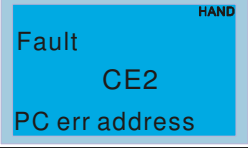
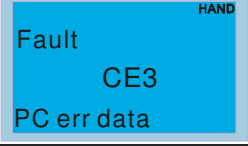
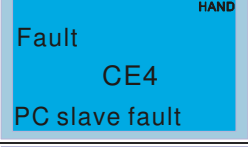
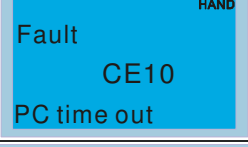
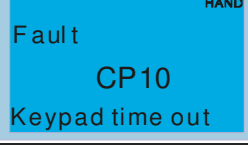
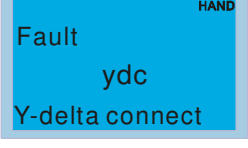
ID No.	KPE-LE02 Display	LCM Display	Descriptions
24	oH3		<p>Motor overheating The AC motor drive detecting internal temperature exceeds the setting of Pr.06-30 (PTC level)</p> <p>Corrective Actions:</p> <ol style="list-style-type: none"> 1. Make sure that the motor is not obstructed. 2. Ensure that the ambient temperature falls within the specified temperature range. 3. Take the next higher power AC motor drive model.
26	ot1		<p>These two fault codes will be displayed when output current exceeds the over-torque detection level (Pr.06-07 or Pr.06-10) and exceeds over-torque detection (Pr.06-08 or Pr.06-11) and it is set to 2 or 4 in Pr.06-06 or Pr.06-09.</p>
27	ot2		<p>Corrective Actions:</p> <ol style="list-style-type: none"> 1. Check whether the motor is overloaded. 2. Check whether motor rated current setting (Pr.05-01) is suitable 3. Take the next higher power AC motor drive model.
28	uC		<p>Low current</p>
29	LMIT		<p>Limit switching error</p>
30	cF1		<p>Internal EEPROM can not be programmed.</p> <p>Corrective Actions:</p> <ol style="list-style-type: none"> 1. Press “RESET” key to the factory setting. 2. Return to the factory.
31	cF2		<p>Internal EEPROM can not be read.</p> <p>Corrective Actions:</p> <ol style="list-style-type: none"> 1. Press “RESET” key to the factory setting. 2. Return to the factory.
33	cd1		<p>U-phase error</p> <p>Corrective Actions: Re-power on to try it. If fault code is still displayed on the keypad, please return to the factory.</p>
34	cd2		<p>V-phase error</p> <p>Corrective Actions: Re-power on to try it. If fault code is still displayed on the keypad, please return to the factory.</p>
35	cd3		<p>W-phase error</p> <p>Corrective Actions: Re-power on to try it. If fault code is still displayed on the keypad, please return to the factory.</p>
36	Hd0		<p>CC (current clamp)</p> <p>Corrective Actions: Re-power on to try it. If fault code is still displayed on the keypad, please return to the factory.</p>

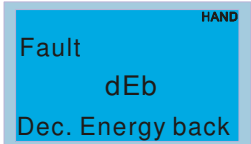
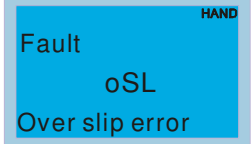
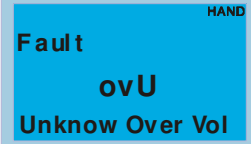
ID No.	KPE-LE02 Display	LCM Display	Descriptions
37	Hd1	 The LCM display shows the word 'Fault' at the top, 'Hd1' in the middle, and 'Oc HW error' at the bottom. A 'HAND' indicator is visible in the top right corner of the display area.	OC hardware error Corrective Actions: Re-power on to try it. If fault code is still displayed on the keypad, please return to the factory.
38	Hd2	 The LCM display shows the word 'Fault' at the top, 'Hd2' in the middle, and 'Ov HW error' at the bottom. A 'HAND' indicator is visible in the top right corner of the display area.	OV hardware error Corrective Actions: Re-power on to try it. If fault code is still displayed on the keypad, please return to the factory.
39	Hd3	 The LCM display shows the word 'Fault' at the top, 'Hd3' in the middle, and 'occ HW error' at the bottom. A 'HAND' indicator is visible in the top right corner of the display area.	Occ hardware error Corrective Actions: Reboots the power. If fault code is still displayed on the keypad please return to the factory
40	AUE	 The LCM display shows the word 'Fault' at the top, 'AUE' in the middle, and 'Auto tuning err' at the bottom. A 'HAND' indicator is visible in the top right corner of the display area.	Auto tuning error Corrective Actions: 1. Check cabling between drive and motor 2. Check the motor capacity and parameters settings 3. Retry again
41	AFE	 The LCM display shows the word 'Fault' at the top, 'AFE' in the middle, and 'PID Fbk error' at the bottom. A 'HAND' indicator is visible in the top right corner of the display area.	PID loss (ACI) Corrective Actions: 1. Check the wiring of the PID feedback 2. Check the PID parameters settings
42	PGF1	 The LCM display shows the word 'Fault' at the top, 'PGF1' in the middle, and 'PG Fbk error' at the bottom. A 'HAND' indicator is visible in the top right corner of the display area.	PG feedback error Corrective Actions: Check if Pr.10-01 is not set to 0 when it is PG feedback control
43	PGF2	 The LCM display shows the word 'Fault' at the top, 'PGF2' in the middle, and 'PG Fbk loss' at the bottom. A 'HAND' indicator is visible in the top right corner of the display area.	PG feedback loss Corrective Actions: Check the wiring of the PG feedback
44	PGF3	 The LCM display shows the word 'Fault' at the top, 'PGF3' in the middle, and 'PG Fbk over SPD' at the bottom. A 'HAND' indicator is visible in the top right corner of the display area.	PG feedback stall Corrective Actions: 1. Check the wiring of the PG feedback 2. Check if the setting of PI gain and deceleration is suitable 3. Return to the factory
45	PGF4	 The LCM display shows the word 'Fault' at the top, 'PGF4' in the middle, and 'PG Fbk deviate' at the bottom. A 'HAND' indicator is visible in the top right corner of the display area.	PG slip error Corrective Actions: 1. Check the wiring of the PG feedback 2. Check if the setting of PI gain and deceleration is suitable 3. Return to the factory
48	ACE	 The LCM display shows the word 'Fault' at the top, 'ACE' in the middle, and 'ACI loss' at the bottom. A 'HAND' indicator is visible in the top right corner of the display area.	ACI loss Corrective Actions: 1. Check the ACI wiring Check if the ACI signal is less than 4mA
49	EF	 The LCM display shows the word 'Fault' at the top, 'EF' in the middle, and 'External fault' at the bottom. A 'HAND' indicator is visible in the top right corner of the display area.	External Fault Corrective Actions: 1. Input EF (N.O.) on external terminal is closed to GND. Output U, V, W will be turned off. 2. Give RESET command after fault has been cleared.

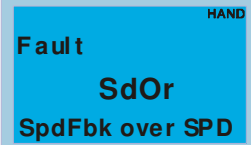
ID No.	KPE-LE02 Display	LCM Display	Descriptions
50	EF 1		Emergency stop Corrective Actions: 1. When the multi-function input terminals MI1 to MI8 are set to emergency stop and the AC motor drive stops output. 2. Press RESET after fault has been cleared.
51	bb		Base Block Corrective Actions: 1. When the multi-function input terminals MI1 to MI8 are set to base block and the AC motor drive stops output. 2. Press RESET after fault has been cleared.
52	Pcod		Password is locked Corrective Actions: Keypad will be locked. Turn the power ON after power OFF to re-enter the correct password. See Pr.00-07 and 00-08.
53	ccod		SW code error
54	CE 1		Illegal function code Corrective Actions: Check if the function code is correct (function code must be 03, 06, 10, 63)
55	CE 2		Illegal data length Corrective Actions: Check if the communication data length is correct.
56	CE 3		Illegal data value Corrective Actions: Check if the data value exceeds max./min. value.
57	CE 4		illegal communication address Corrective Actions: Check if the communication address is correct.
58	CE 10		Communication time-out Corrective Actions: Check if the wiring for the communication is correct.
59	CP 10		Keypad communication error (time out)
61	ydc		Y-connection/Δ-connection switch error Corrective Actions: 1. Check the wiring of the Y-connection/Δ-connection 2. Check the parameters settings

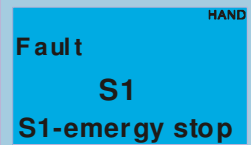
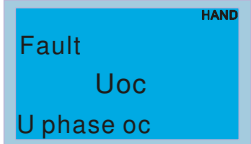
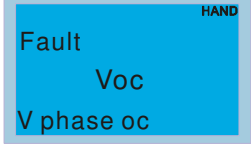
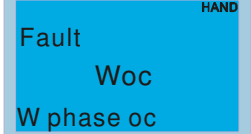
ID No.	KPE-LE02 Display	LCM Display	Descriptions
62	dEb		<p>When Pr.07-13 is not set to 0 and momentary power off or power cut, it will display dEb during accel./decel. stop.</p> <p>Corrective Actions:</p> <ol style="list-style-type: none"> Set Pr.07-13 to 0 Check if input power is stable
63	oSL		<p>It will be displayed when slip exceeds Pr.07-29 setting and time exceeds Pr.07-30 setting.</p> <p>Corrective Actions:</p> <ol style="list-style-type: none"> Check if motor parameter is correct (please decrease the load if overload) Check the settings of Pr.07-29 and Pr.07-30
66	ocU		Unknow Over Amp
67	ouU		Unknow Over Vol
68	Sdrv		Estimated speed is not in the same direction with speed command
69	Sdor		Estimated speed is greater than speed command
70	Sdde		Estimated speed has great speed deviation
73	S1		Safety protection error
79	Uoc		U phase short circuit
80	voc		V phase short circuit
81	woc		W phase short circuit

ID No.	KPE-LE02 Display	LCM Display	Descriptions
82	OPHL	Fault OPHL U phase lacked	Output phase loss (Phase U)
83	OPHL	Fault OPHL V phase lacked	Output phase loss (Phase V)
84	OPHL	Fault OPHL W phase lacked	Output phase loss (Phase W)
101	CGdE	Fault CGdE Guarding T-out	CANopen guarding fail
102	CHbE	Fault CHbE Heartbeat T-out	CANopen heartbeat fail
103	CSyE	Fault CSyE SYNC T-out	CANopen sync fail
104	CbFE	Fault CbFE CAN/S Bus Off	CANopen bus-off fail
105	CIdE	Fault CIdE CAN/S Idx exceed	CANopen index fail
106	CAdE	Fault CAdE CAN/S Addres set	CANopen address fail
107	CFrE	Fault CFrE CAN/S FRAM fail	CANopen memory fail
111	ictE	Fault ictE InnerCom TimeOut	InnerCOM time out fail

Chapter 13 CANopen Overview

- 13-1 CANopen Overview
- 13-2 Wiring for CANopen
- 13-3 How to control by CANopen
 - 13-3-1 CANopen Control Mode Selection
 - 13-3-2 DS402 Standard Control Mode
 - 13-3-3 Delta Defined Control Mode (There are two modes available)
- 13-4 CANopen Supporting Index
- 13-5 CANopen Fault Code
- 13-6 CANopen LED Function

The built-in CANopen function is a kind of remote control. Master can control the AC motor drive by using CANopen protocol. CANopen is a CAN-based higher layer protocol. It provides standardized communication objects, including real-time data (Process Data Objects, PDO), configuration data (Service Data Objects, SDO), and special functions (Time Stamp, Sync message, and Emergency message). And it also has network management data, including Boot-up message, NMT message, and Error Control message. Refer to CiA website <http://www.can-cia.org/> for details. The content of this instruction sheet may be revised without prior notice. Please consult our distributors or download the most updated version at <http://www.delta.com.tw/industrialautomation/>

Delta CANopen supporting functions:

- Support CAN2.0A Protocol;
- Support CANopen DS301 V4.02;
- Support DSP-402 V2.0.

Delta CANopen supporting services:

- PDO (Process Data Objects): PDO1~ PDO2
- SDO (Service Data Object):
 - Initiate SDO Download;
 - Initiate SDO Upload;
 - Abort SDO;
 - SDO message can be used to configure the slave node and access the Object Dictionary in every node.
- SOP (Special Object Protocol):
 - Support default COB-ID in Predefined Master/Slave Connection Set in DS301 V4.02;
 - Support SYNC service;
 - Support Emergency service.
- NMT (Network Management):
 - Support NMT module control;
 - Support NMT Error control;
 - Support Boot-up.

Delta CANopen not supporting service:

- Time Stamp service

13-1 CANopen Overview

CANopen Protocol

CANopen is a CAN-based higher layer protocol, and was designed for motion-oriented machine control networks, such as handling systems. Version 4 of CANopen (CiA DS301) is standardized as EN50325-4. The CANopen specifications cover application layer and communication profile (CiA DS301), as well as a framework for programmable devices (CiA 302), recommendations for cables and connectors (CiA 303-1) and SI units and prefix representations (CiA 303-2).

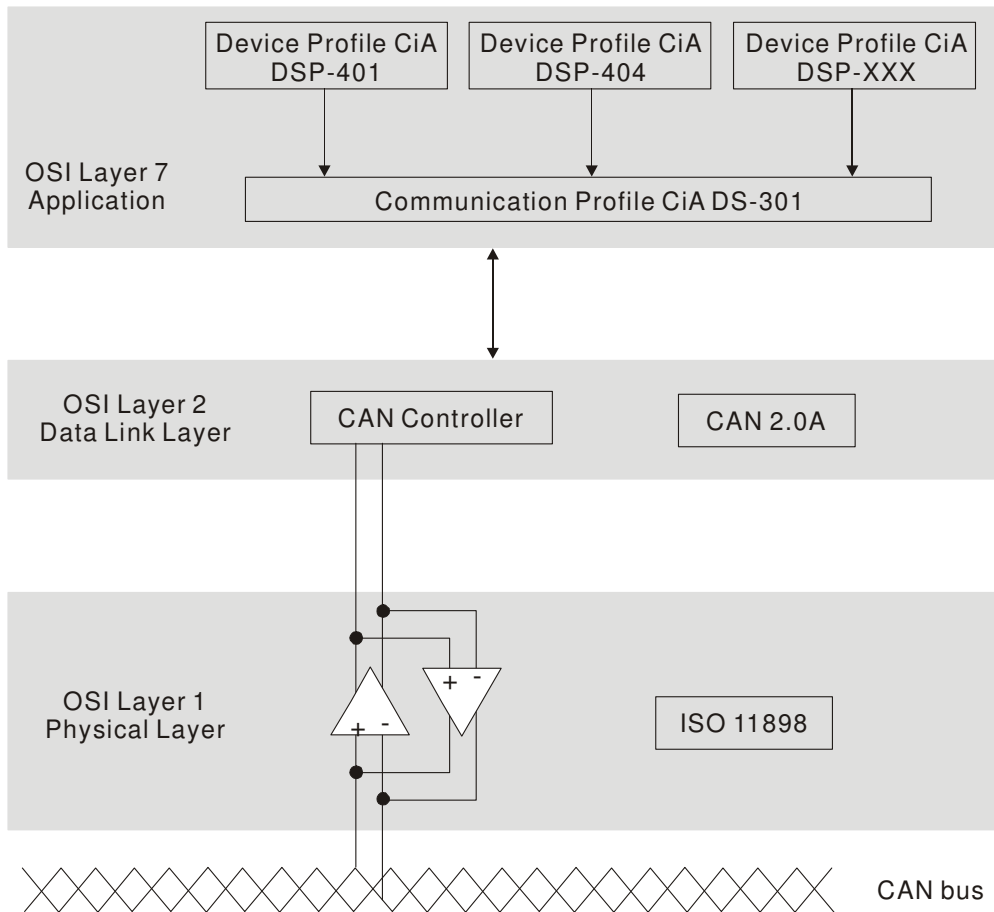

RJ-45 Pin Definition

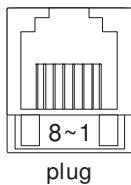

PIN	Signal	Description
1	CAN_H	CAN_H bus line (dominant high)
2	CAN_L	CAN_L bus line (dominant low)
3	CAN_GND	Ground / 0V /V-
6	CAN_GND	Ground / 0V /V-

CANopen Communication Protocol

It has services as follows:

- NMT (Network Management Object)
- SDO (Service Data Objects)
- PDO (Process Data Object)
- EMCY (Emergency Object)

NMT (Network Management Object)

The Network Management (NMT) follows a Master/Slave structure for executing NMT service. Only one NMT master is in a network, and other nodes are regarded as slaves. All CANopen nodes have a present NMT state, and NMT master can control the state of the slave nodes. The state diagram of a node is shown as follows:

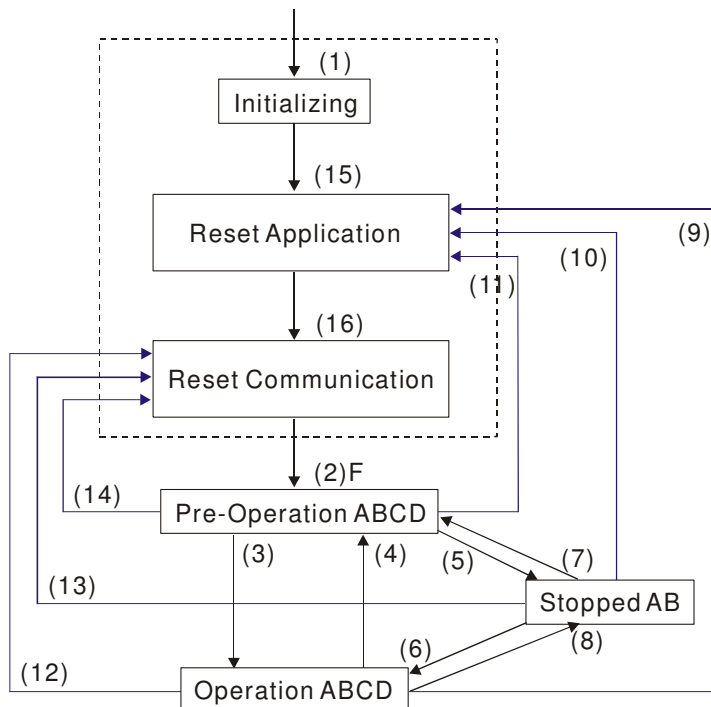

- (1) After power is applied, it is auto in initialization state
- (2) Enter pre-operational state automatically
- (3) (6) Start remote node
- (4) (7) Enter pre-operational state
- (5) (8) Stop remote node
- (9) (10) (11) Reset node
- (12) (13) (14) Reset communication
- (15) Enter reset application state automatically
- (16) Enter reset communication state automatically

- A: NMT
- B: Node Guard
- C: SDO
- D: Emergency
- E: PDO
- F: Boot-up

	Initializing	Pre-Operational	Operational	Stopped
PDO			○	
SDO		○	○	
SYNC		○	○	
Time Stamp		○	○	
EMCY		○	○	
Boot-up	○			
NMT		○	○	○

SDO (Service Data Objects)

SDO is used to access the Object Dictionary in every CANopen node by Client/Server model. One SDO has two COB-ID (request SDO and response SDO) to upload or download data between two nodes. No data limit for SDOs to transfer data. But it needs to transfer by segment when data exceeds 4 bytes with an end signal in the last segment.

The Object Dictionary (OD) is a group of objects in CANopen node. Every node has an OD in the system, and OD contains all parameters describing the device and its network behavior. The access path of OD is the index and sub-index, each object has a unique index in OD, and has sub-index if necessary.

PDO (Process Data Object)

PDO communication can be described by the producer/consumer model. Each node of the network will listen to the messages of the transmission node and distinguish if the message has to be processed or not after receiving the message. PDO can be transmitted from one device to one another device or to many other devices. Every PDO has two PDO services: a TxPDO and a RxPDO. PDOs are transmitted in a non-confirmed mode.

PDO Transmission type is defined in the PDO communication parameter index (1400h for the 1st RxPDO or 1800h for the 1st TxPDO), and all transmission types are listed in the following table:

Type number	PDO				
	Cyclic	Acyclic	Synchronous	Asynchronous	RTR only
0		○	○		
1-240	○		○		
241-251	Reserved				
252			○		○
253				○	○
254				○	
255				○	

Type number 1-240 indicates the number of SYNC message between two PDO transmissions.

Type number 252 indicates the data is updated (but not sent) immediately after receiving SYNC.

Type number 253 indicates the data is updated immediately after receiving RTR.

Type number 254: Delta CANopen doesn't support this transmission format.

Type number 255 indicates the data is asynchronous transmission.

All PDO transmission data must be mapped to index via Object Dictionary.

Example:

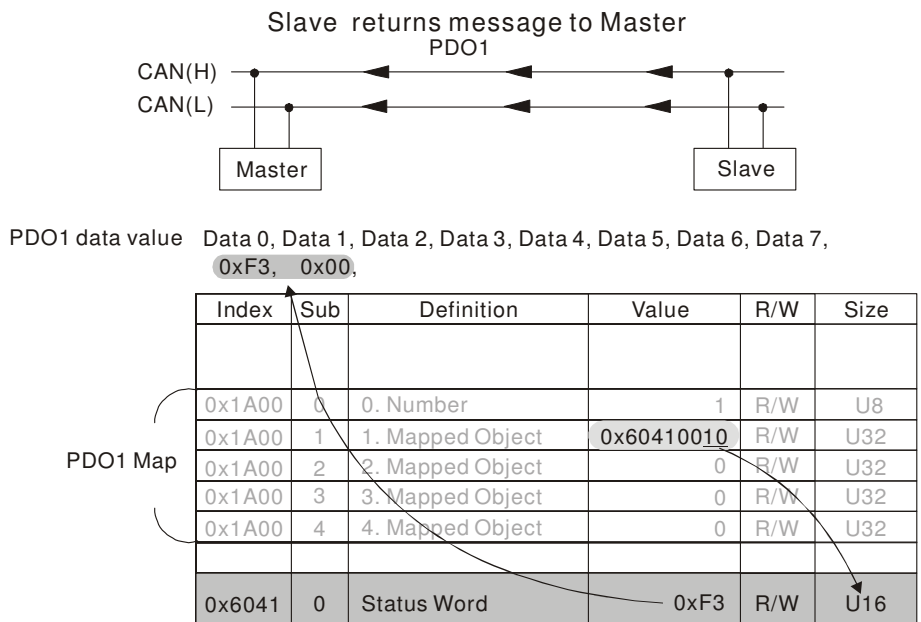
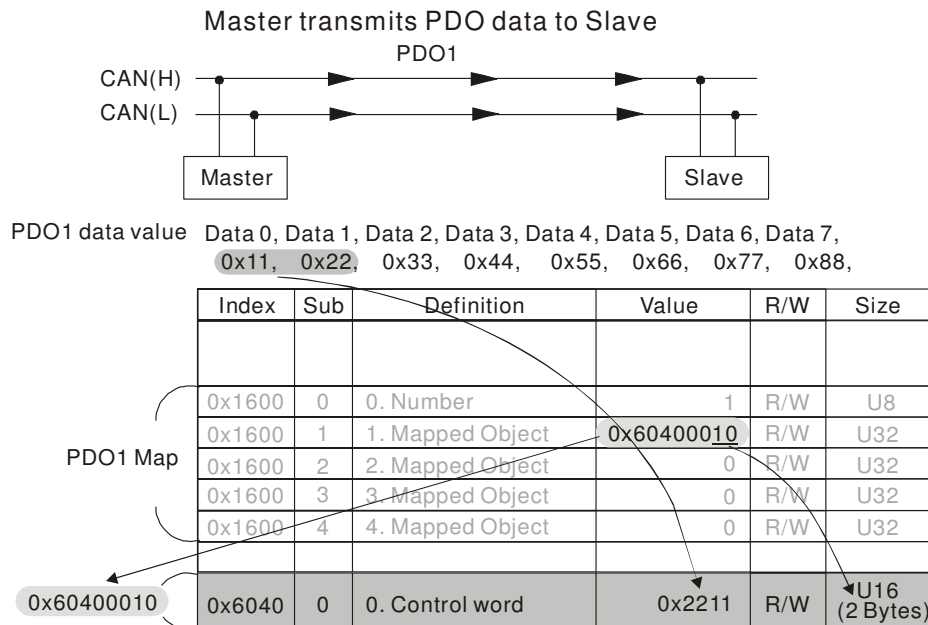

EMCY (Emergency Object)

Emergency objects are triggered when hardware failure occurs for a warning interrupt. The data format of a emergency object is a 8 bytes data as shown in the following:

Byte	0	1	2	3	4	5	6	7
Content	Emergency Error Code		Error register (Object 1001H)		Manufacturer specific Error Field			

Please refer to Chapter 13.5 CANopen error codes for emergency definition of C200.

13-2 Wiring for CANopen

An external adapter card: EKCB-HUB01 is used for CANopen wiring; establish CANopen to VFD C200 connection. The link is enabled by using RJ45 cable. The two farthest ends must be terminated with 120Ω terminating resistors.

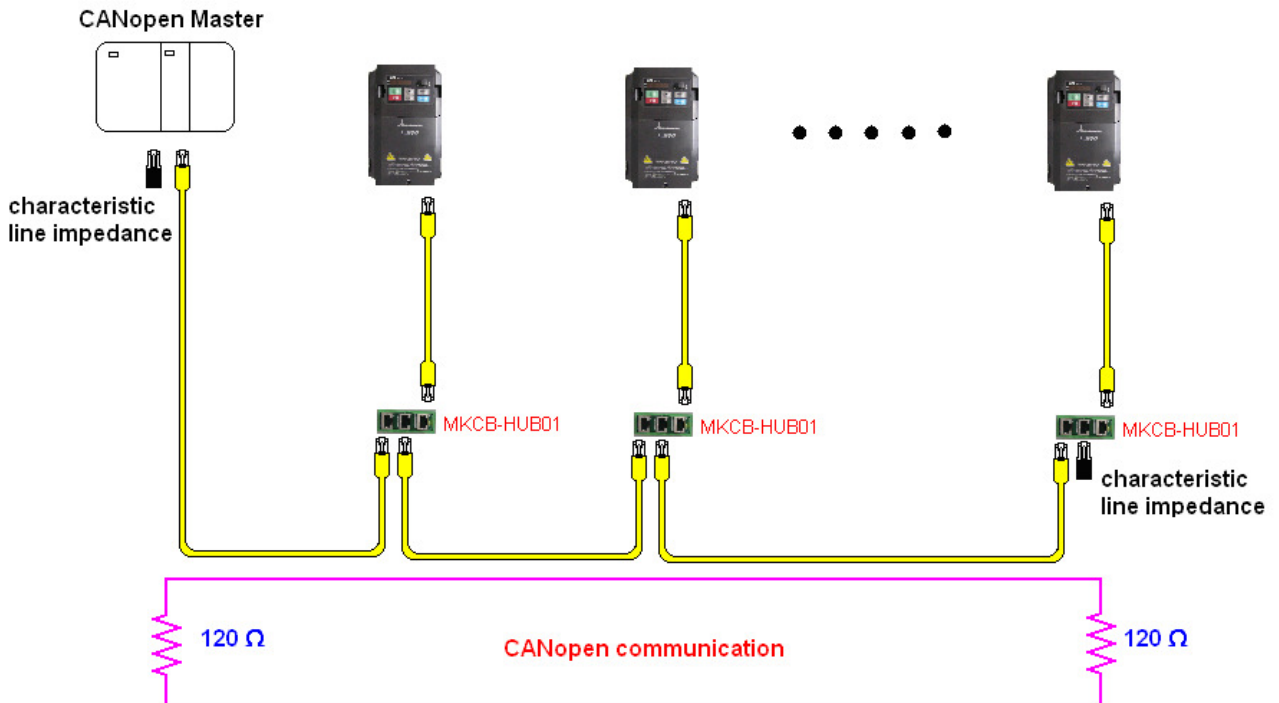

13-3 How to Control by CANopen

13-3-1 CANopen Control Mode Selection

There are two control modes for CANopen; Pr.09-40 set to 1 is the factory setting mode DS402 standard and Pr.09.40 set to 0 is Delta's standard setting mode.

Actually, there are two control modes according to Delta's standard, one is the old control mode (Pr09-30=0).

This control mode can only control the motor drive under frequency control. Another mode is a new standard (Pr09-30=1)

CANopen Control Mode Selection	Control Mode							
	Speed		Torque		Operation Control		Other	
	Index	Description	Index	Description	Index	Description	Index	Description
DS402 standard P09-40=1	6042-00	Target rotating speed (RPM)	6071-00	Target torque (%)	6040-00	Operation command	605A-00	Quick stop processing mode
	-----	-----	6072-00	Max. torque limit (%)	-----	-----	605C-00	Disable operation processing mode
Delta standard (Old definition) P09-40=0, P09-30=0	2020-02	Target rotating speed (Hz)	-----	-----	2020-01	Operation command	-----	-----
Delta standard (New definition) P09-40=0, P09-30=1	2060-03	Target rotating speed (Hz)	2060-07	Target torque (%)	2060-01	Operation command	-----	-----
	2060-04	Torque limit (%)	2060-08	Speed limit (Hz)	-----	-----	-----	-----

However, you can use some index regardless DS402 or Delta's standard.

For example:

1. Index which are defined as RO attributes.
2. Index correspond to parameters such as (2000 ~200B-XX)

13-3-2 DS402 Standard Control Mode

To control the AC motor drive by CANopen, please set the parameters by the following steps:

1. Wiring for hardware (refer to Chapter 2 Wiring for CANopen)
2. Operation source setting: set Pr.00.21 to 3 (CANopen communication. Keypad STOP/RESET disabled.)
3. Frequency source setting: set Pr.02.00 to 6 for CANopen communication card control. For CANopen to do torque control, set Pr.11-33 to 3; to do position control, set Pr.11-40 to 3. Also set Pr.09-30 to 1 (decoding method 2), use new address 60XX to control torque and position. The old address 20XX does not support torque and position control.
4. Source of torque setting is set by Pr.11-33.
5. CANopen station setting: set Pr.09-36 (Range of setting is 1~127. When Pr.09-36=0, CANopen slave function is disabled.) (Note: If error occurred (CAde or CANopen memory error) as station setting is completed, press Pr.00-02=7 for reset.)
6. CANopen baud rate setting: set Pr.09.37 (CANBUS Baud Rate: 1M(0), 500K(1), 250K(2), 125K(3), 100K(4) and50K(5))

7. Set multiple input functions to Quick Stop (it can also be enable or disable, default setting is disable). If it is necessary to enable the function, set MI terminal to 53 in one of the following parameter: Pr.02.01 ~Pr.02.08 or Pr.02.26 ~ Pr.02.31. (Note: This function is available in DS402 only.)
8. Switch to C2000 operation mode via the NMT string; control word 0x6040 (bit 0, bit 1, bit 2, bit 3 and bit 7) and status word 0x6041.

For example:

1. If the multi-function input terminal MI set Quick Stop to disable, enable the responsive terminal of such MI terminal.
2. Set index 6040H to 7EH.
3. Set index 6040H to 7FH, the drive is now in operation mode.
4. Set index 6042H to 1500 (rpm), the default setting for pole is 4 (50Hz). Set the pole in Pr.05.04 (Motor1) and Pr.05.16 (Motor 2).

Calculation for motor speed: $n = f \times \frac{120}{P}$ where $n =$ ramp per minute (rpm/min);
 $P =$ poles
 $f =$ frequency (Hz)

Example 1: set motor running in forward direction, $f = 30\text{Hz}$, $P = 4$.
 $(120 \times 30) / 4 = 900\text{rpm}$

Example 2: set motor running in reverse direction, $f = 20\text{Hz}$, $P = 6$.
 $(120 \times 15) / 6 = 300\text{rpm}$; $300\text{rpm} = 0x012C$
 Also,

Bit15 defines the positive and negative sign.

i.e. Index 6042 = -300 = (300' + 1) = 012CH' + 1 = FED3H + 1 = FED4H

Switching mode:

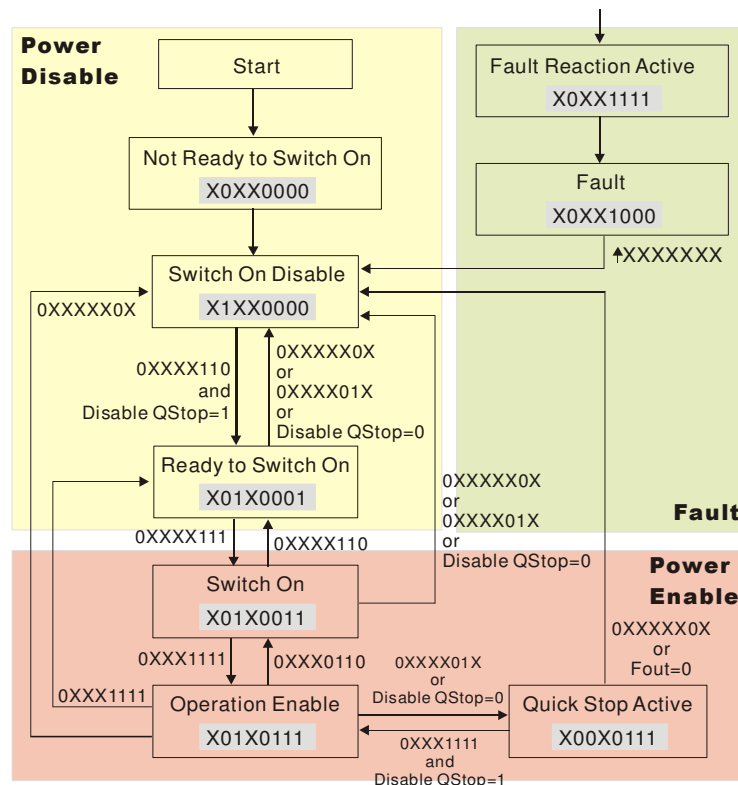

< Status Switching Graph >

9. The operation of AC motor drive in DS402 standard is controlled by the Control Word 0x6040 (bit4~bit6), as shown in the following chart:

	Index 6040			END
	bit 6	bit 5	bit 4	
Speed (Index 6060=2)	Other			Decelerate to 0Hz
	1	0	1	Locked at the current signal.
	1	1	1	Run to reach targeting signal.
	Index 6040			END
	bit 6	bit 5	bit 4	
Torque (Index 6060=4)	X	X	X	RUN to reach the targeting torque.

10. Follow the same steps, refer to status switching process for status word 0x6041 (bit 0 to bit 6), bit 7= warn, bit 9 = 1 (permanently), bit 10= target frequency reached, bit 11= output exceeds maximum frequency.

13-3-3 Delta Defined Control Mode

There are two control modes.

1. Wiring for hardware (refer to chapter 13-2 Wiring for CANopen)
2. Operation source setting: set Pr.00-21 to 3 for CANopen communication control.
3. Frequency source setting: set Pr.00.20 to 6 (CANopen setting. If torque control or position control is required, set Pr.0.02 to 2. Also set Pr.09.30 to 1 (default setting) to allow new address 60XX to function, the old address 20XX can not support the control function for position and torque.
4. Source of torque setting is set by Pr.11-33.
5. CANopen station setting: set Pr.09-36 (Range of setting is 1~127. When Pr.09-36=0, CANopen slave function is disabled.) (Note: If error occurred (CAde or CANopen memory error) as station setting is completed, press Pr.00-02=7 for reset.)
6. CANopen baud rate setting: set Pr.09.37 (CANopen Baud Rate: 1M(0), 500K(1), 250K(2), 125K(3), 100K(4) and 50K(5))
7. CANopen decode method setting: set Pr.09.40 to 0 (Delta decoding method). It provides two decoding method by using Pr.09-30 and the default setting of the drive is in decoding method 2 (Pr.09-30=1).
8. Decoding method 1. In index 2020.01 enter 0002H for motor run; 0001H for motor stop. In index 2020.02 enter 1000, frequency will be 10.00Hz. Refer to Index 2020 and 2021 for more detail.
9. Decoding method 2. In index 2060.01 enter 0080H for motor switch on; enter 0x81 for motor run to the target frequency. Various control mode options are available in Pr.00-40, select your control mode.

13-4 CANopen Supporting Index

C200 Index:

Parameter index corresponds to each other as following:

Index	sub-Index
2000H + Group	member+1

For example:

Pr.10.15 (Encoder Slip Error Treatment)

Group	member
10(0 \bar{A} H)	- 15(0FH)

Index = 2000H + 0AH = 200A

Sub Index = 0FH + 1H = 10H

C200 Control Index:

Delta Standard Mode (Old definition)

Index	Sub	Definition	Factory setting	R/W	Size	Note					
2020H	0	Number	3	R	U8						
	1	Control word	0	RW	U16	bit 0~1	00B: Disable 01B: Stop 10B: Enable 11B: JOG enable				
						bit2~3	Reserved				
						bit4~5	00B: Disable 01B: Forward direction 10B: Reverse direction 11B: Direction switch				
							bit6~7	00B: 1 st step acceleration / deceleration 01B: 2 nd step acceleration / deceleration			
								bit8~15	Reserved		
						2	vl target velocity (Hz)	0	RW	U16	
						3	Other trigger	0	RW	U16	bit0
	bit1	1: Reset									
							bit2~15	Reserved			
2021H	0	Number	DH	R	U8						
	1	Error code	0	R	U16						
2021H	2	AC motor drive status	0	R	U16	bit 0~1	00B: Stop 01B: Decelerate and stop 10B: Waiting for operation command 11B: In operation				
						bit 2	1: JOG command				

Index	Sub	Definition	Factory setting	R/W	Size	Note
						bit 3~4 00B: Forward running 01B: Switch from reverse running to forward running 10B: Switch from forward running to reserve running 11B: Reverse running
						bit 5~7 Reserved
						bit 8 1: Master frequency command controlled by communication interface
						bit 9 1: Master frequency command controller by analog signal input
						bit 10 1: Operation command controlled by communication interface
						bit 11~15 Reserved
	3	Frequency command (F)	0	R	U16	
	4	Output frequency (H)	0	R	U16	
	5	Output current (AXX.X)	0	R	U16	
	6	DC bus voltage	0	R	U16	
	7	Output voltage	0	R	U16	
	8	The segment currently executed by multi-segment speed command	0	R	U16	
	9	Display output current (A)	0	R	U16	
	A	Display counter value (c)	0	R	U16	
	B	Display actual output frequency (H)	0	R	U16	
	C	Display DC bus voltage (u)	0	R	U16	
	D	Display output voltage (E)	0	R	U16	
	E	Display output power angle (n)	0	R	U16	
	F	Display output power in Kw (P)	0	R	U16	
	10	Display actual motor speed in rpm (r)	0	R	U16	
	11	Display estimate output torque % (t)	0	R	U16	
	12	Reserved	0	R	U16	
	13	Display PID feedback in % (b)	0	R	U16	
	14	Display AVI in % (1.)	0	R	U16	
	15	Display ACI in % (2.)	0	R	U16	
	16	Display AUI in % (3.)	0	R	U16	
	17	Display the temperature of IGBT in °C (i.)	0	R	U16	
2021H	18	Display the temperature of capacitance in °C (c.)	0	R	U16	

Index	Sub	Definition	Factory setting	R/W	Size	Note
	19	The status of digital input (ON/OFF) (i)	0	R	U16	
	1A	The status of digital output (ON/OFF) (o)	0	R	U16	
	1B	Multi-speed (S)	0	R	U16	
	1C	The corresponding CPU pin status of digital output (d.)	0	R	U16	
	1D	Reserved	0	R	U16	
	1E	Reserved	0	R	U16	
	1F	Reserved	0	R	U16	
	20	Reserved	0	R	U16	
	21	Reserved	0	R	U16	
	22	Reserved	0	R	U16	
	23	Reserved	0	R	U16	
	24	Reserved	0	R	U16	
	25	Display PLC data D1043 (C)	0	R	U16	

Delta Standard Mode (New definition)

Index	sub	R/W	bit	Value	Name of bit	Priority	Speed Mode	Torque Mode	
	00h	R							
2060h	01h	RW	0	0	CMD_ACT	4	fcmd = 0	Tcmd = 0	
				Pulse 0			fcmd = Fset(Fpid)	Tcmd = Tset	
			1	1	Dir	4	0: FWD run command		
				Pulse 1			1: REV run command		
			2						
			3	0	HALT	3	Drive runs till target speed is attained	Free (Keep running to reach target torque)	
				1			Drive stops by deceleration setting	Lock (Torque stops at current speed)	
			4	0	LOCK	4	Drive runs till target speed is attained		
				1			Frequency stops at current frequency		
			5	0	JOG	4	JOG OFF	JOG OFF	
				1					
				Pulse 1			JOG RUN	JOG RUN	
			6	0	QSTOP	2	None	None	
				1			Quick Stop	Quick Stop	
			7	0	SERVO_ON	1	Servo OFF	Servo OFF	
				1			Servo ON	Servo ON	
			11~8	0000	GEAR	4	Master speed	Master torque	
				0001~1111			1 st ~15 th speed switching frequency		
			13~12	00	ACC/DEC	4	1 st accel. / decel.		
				01			2 nd accel. / decel.		

Index	sub	R/W	bit	Value	Name of bit	Priority	Speed Mode	Torque Mode
				10			3 rd accel. / decel.	
				11			4 th accel. / decel.	
			14	EN_SW	4	0	Multi- command and Accel./Decel. Time switching NOT allowed	Multi- command and Accel./Decel. Time switching NOT allowed
						1	Multi- command and Accel./Decel. Time switching ALLOWED	Multi- command and Accel./Decel. Time switching ALLOWED
			15	Pulse 1	RST	4	Clear fault codes	Clear fault codes
	02h	RW						
	03h	RW					Speed command (unsigned decimal)	
	04h	RW						-
	05h	RW						-
	06h	RW						
07h	RW						Torque command (signed decimal)	
08h	RW						Speed limit (unsigned decimal)	
2061h	01h	R	0	0	ARRIVE		Frequency command not reached	Torque command not reached
				1		Frequency attained	Torque attained	
			2~1	0	DIR		FWD	FWD
				01			REV run switches to FWD run	REV run switches to FWD run
				10			FWD run switches to REV run	FWD run switches to REV run
				11			REV	REV
			5	0	JOG		None	None
				1			On JOG	On JOG
			6	0	QSTOP		None	None
				1			On Quick Stop	On Quick Stop
			7	0	SERVO_ON		PWM OFF	PWM OFF
				1			PWM ON	PWM ON
			8	0	PRLOCK		Parameters NOT locked	Parameters NOT locked
				1			Parameters LOCKED	Parameters LOCKED
			9	0	WARN		NO warning	NO warning
	1				Warning	Warning		
	10	0	ERROR		No error	No error		
		1			Error detected	Error detected		
	11	0	IGBT_OK		IGBT OFF	IGBT OFF		
		1			IGBT ON	IGBT ON		
15~11	-	-	-	-	-			
02h	R			Velocity cmd		Actual output frequency	Actual output frequency	
03h	R			-				
04h	R	-						
05h	R					Actual position (absolute)	Actual position (absolute)	
06h	R			Torq Cmd				
07h	R					Actual torque	Actual torque	

DS402 Standard

Index	Sub	Defenition	Factory setting	R/W	Size	Unit	PDO Map	Mode	Note
6007h	0	Abort connection option code	2	RW	S16		Yes		0 : No action 2 : Disable Voltage, 3 : quick stop
603Fh	0	Error code	0	R0	U16		Yes		
6040h	0	Control word	0	RW	U16		Yes		
6041h	0	Status word	0	R0	U16		Yes		
6042h	0	vl target velocity	0	RW	S16	rpm	Yes	vl	
6043h	0	vl velocity demand	0	RO	S16	rpm	Yes	vl	
6044h	0	vl control effort	0	RO	S16	rpm	Yes	vl	
604Fh	0	vl ramp function time	10000	RW	U32	1ms	Yes	vl	The unit must be: 100ms, and check if the setting is set to 0.
6050h	0	vl slow down time	10000	RW	U32	1ms	Yes	vl	
6051h	0	vl quick stop time	1000	RW	U32	1ms	Yes	vl	
605Ah	0	Quick stop option code	2	RW	S16		No		0 : disable drive function 1 :slow down on slow down ramp 2: slow down on quick stop ramp 5 slow down on slow down ramp and stay in QUICK STOP 6 slow down on quick stop ramp and stay in QUICK STOP
605Ch	0	Disable operation option code	1	RW	S16		No		0: Disable drive function 1: Slow down with slow down ramp; disable of the drive function
6060h	0	Mode of operation	2	RW	S8		Yes		2: Velocity Mode 4: Torque Profile Mode
6061h	0	Mode of operation display	2	RO	S8		Yes		Same as above
6071h	0	tq Target torque	0	RW	S16	0.1%	Yes	tq	Valid unit: 1%
6072h	0	tq Max torque	150	RW	U16	0.1%	No	tq	Valid unit: 1%
6075h	0	tq Motor rated current	0	RO	U32	mA	No	tq	
6077h	0	tq torque actual value	0	RO	S16	0.1%	Yes	tq	
6078h	0	tq current actual value	0	RO	S16	0.1%	Yes	tq	
6079h	0	tq DC link circuit voltage	0	RO	U32	mV	Yes	tq	

13-5 CANopen Fault Code

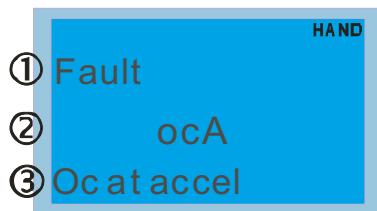

- ① Display error signal
- ② Abbreviate error code
The code is displayed as shown on KPC-CE01.
- ③ Display error description

*: Based on the setting of Pr.06-17~06-22

ID No.*	LCM Display	Fault Codes	Description	CANopen Fault Register (bit 0~7)	CANopen Fault Codes
1	Fault ocA Oc at accel	0001H	Over-current during acceleration	1	2213H
2	Fault ocd Oc at decel	0002H	Over-current during deceleration	1	2213H
3	Fault ocn Oc at normal SPD	0003H	Over-current during steady state operation	1	2214H
4	Fault GFF Ground fault	0004H	Ground fault	1	2240H
5	Fault occ Short Circuit	0005H	Short-circuit is detected between upper bridge and lower bridge of the IGBT module.	1	2250H
6	Fault ocS Oc at stop	0006H	Over-current at stop	1	2314H
7	Fault ovA Ov at accel	0007H	DC BUS over-voltage during acceleration	2	3210H
8	Fault ovd Ov at decel	0008H	DC BUS over-voltage during deceleration	2	3210H
9	Fault ovn Ov at normal SPD	009H	DC BUS over-voltage during constant speed	2	3210H

ID No.*	LCM Display	Fault Codes	Description	CANopen Fault Register (bit 0~7)	CANopen Fault Codes
10	Fault ovS Ov at stop	000AH	DC BUS over-voltage at stop	2	3210H
11	Fault LvA Lv at accel	000BH	DC BUS voltage is less than Pr.06-00 during acceleration.	2	3220H
12	Fault Lvd Lv at decel	000CH	DC BUS voltage is less than Pr.06-00 during deceleration.	2	3220H
13	Fault Lvn Lv at normal SPD	000DH	DC BUS voltage is less than Pr.06-00 during constant speed.	2	3220H
14	Fault LvS Lv at stop	000EH	Low voltage at stop	2	3220H
15	Fault OrP Phase lacked	000FH	Phase Loss	2	3130H
16	Fault oH1 IGBT over heat	0010H	IGBT overheating 1~15HP: 90°C 20~100HP: 100°C	3	4310H
17	Fault oH2 CAP over heat	0011H	Heatsink overheating	3	4310H
18	Fault tH1o Thermo 1 open	0012H	Motor 1 overload	3	FF00H
19	Fault tH2o Thermo 2 open	0013H	Motor overheating	3	FF01H
21	Fault oL Over load	0015H	Overload	1	2310H
22	Fault EoL1 Thermal relay 1	0016H	Electronic Thermal Relay 1 Protection	1	2310H

ID No.*	LCM Display	Fault Codes	Description	CANopen Fault Register (bit 0~7)	CANopen Fault Codes
23	Fault EoL2 Thermal relay 2	0017H	Electronic Thermal Relay 2 Protection	1	2310H
24	Fault oH3 Motor over heat	0017H	Motor overheating	3	FF20H
26	Fault ot1 Over torque 1	001AH	These two fault codes will be displayed when output current exceeds the over-torque detection level (Pr.06-07 or Pr.06-10) and exceeds over-torque detection (Pr.06-08 or Pr.06-11) and it is set to 2 or 4 in Pr.06-06 or Pr.06-09.	3	8311H
27	Fault ot2 Over torque 2	001BH		3	8311H
28	Fault uC Under Ampere	001CH	Low current	1	8321H
29	Fault LMIT Limit Error	001DH	Limit switching error	1	7320H
30	Fault cF1 EEPROM write err	001EH	Internal EEPROM cannot be programmed.	5	5530H
31	Fault cF2 EEPROM read err	001FH	Internal EEPROM cannot be read	5	5530H
33	Fault cd1 Ias sensor err	0021H	U-phase error	1	FF04H
34	Fault cd2 Ibs sensor err	0022H	V-phase error	1	FF05H
35	Fault cd3 Ics sensor err	0023H	W-phase error	1	FF06H
36	Fault Hd0 cc HW error	0024H	CC (current clamp)	5	FF07H

ID No.*	LCM Display	Fault Codes	Description	CANopen Fault Register (bit 0~7)	CANopen Fault Codes
37	Fault Hd1 Oc HW error	0025H	OC hardware error	5	FF08H
38	Fault Hd2 Ov HW error	0026H	OV hardware error	5	FF09H
39	Fault Hd3 occ HW error	0027H	Occ hardware error	5	FF0aH
40	Fault AUE Auto tuning err	0028H	Auto tuning error	1	FF21H
41	Fault AFE PID Fbk error	0029H	PID loss (ACI)	7	FF22H
42	Fault PGF1 PG Fbk error	002AH	PG feedback error	7	7301H
43	Fault PGF2 PG Fbk loss	002BH	PG feedback loss	7	7301H
44	Fault PGF3 PG Fbk over SPD	002CH	PG feedback stall	7	7301H
45	Fault PGF4 PG Fbk deviate	002DH	PG slip error	7	7301H
48	Fault ACE ACI loss	0030H	ACI loss	1	FF25H
49	Fault EF External fault	0031H	External fault	5	9000H
50	Fault EF1 Emergency stop	0032H	Emergency stop	5	9000H

ID No.*	LCM Display	Fault Codes	Description	CANopen Fault Register (bit 0~7)	CANopen Fault Codes
51	Fault bb Base block	0033H	Emergency block	5	9000H
52	Fault Pcod Password error	0034H	Password is locked	5	FF26H
53	Fault ccod SW Code Error	0035H	SW code error	5	6100H
54	Fault CE1 PC err command	0036H	Illegal function code	4	7500H
55	Fault CE2 PC err address	0037H	Illegal data length	4	7500H
56	Fault CE3 PC err data	0038H	Illegal data value	4	7500H
57	Fault CE4 PC slave fault	0039H	Illegal communication address	4	7500H
58	Fault CE10 PC time out	003AH	Communication time-out	4	7500H
59	Fault CP10 Keypad time out	003BH	Keypad communication err (time out)	4	7500H
61	Fault ydc Y-delta connect	003DH	Y-connection / Δ -connection switch error	2	3330H
62	Fault dEb Dec. Energy back	003EH	When Pr.07-13 is not set to 0 and momentary power off or power cut, it will display dEb during accel. / decel. Stop.	2	FF27H
63	Fault oSL Over slip error	003FH	It will be displayed when slip exceeds Pr.07-29 setting and time exceeds Pr.07-30 setting	7	FF28H

ID No.*	LCM Display	Fault Codes	Description	CANopen Fault Register (bit 0~7)	CANopen Fault Codes
66	Fault ovU Unknow Over Amp	0042H	Unknow Over Amp	1	2310H
67	Fault ovU Unknow Over Vol	0043H	Unknow Over Vol	2	3210H
68	Fault SdRv SpdFbk Dir Rev	0044H	Estimated speed is not in the same direction with speed command	7	8400H
69	Fault SdOr SpdFbk over SPD	0045H	Estimate speed is greater than speed command	7	8400H
70	Fault SdDe SpdFbk device	0046H	Estimated speed has great speed deviation	7	8400H
73	Fault S1 S1-emergy stop	0049H	Safety protection error	5	FF2AH
79	Fault Uoc U phase oc	0050H	U phase short circuit	1	FF2BH
80	Fault Voc V phase oc	0051H	V phase short circuit	1	FF2CH
81	Fault Woc W phase oc	0052H	W phase short circuit	1	FF2DH
82	Fault OPHL U phase lacked	0052H	Output phase loss (U phase)	2	2331H
83	Fault OPHL V phase lacked	0053H	Output phase loss (V phase)	2	2332H
84	Fault OPHL W phase lacked	0054H	Output phase loss (W phase)	2	2333H

ID No.*	LCM Display	Fault Codes	Description	CANopen Fault Register (bit 0~7)	CANopen Fault Codes
101	Fault CGdE Guarding T-out	0065H	CANopen guarding fail	4	8130H
102	Fault CHbE Heartbeat T-out	0066H	CANopen heartbeat fail	4	8130H
103	Fault CSYE SYNC T-out	0067H	CANopen synchronous fail	4	8700H
104	Fault CbFE CAN/S Bus Off	0068H	CANopen bus-off error	4	8140H
105	Fault CIdE CAN/S Idx exceed	0069H	CANopen index fail	4	8100H
106	Fault CAdE CAN/S Adres set	006AH	CANopen address fail	4	8100H
107	Fault CFrE CAN/S FRAM fail	006BH	CANopen memory fail	4	8100H
111	Fault ictE InnerCom TimeOut	006FH	InnerCOM time out fail	4	7500H

13-6 CANopen LED Function

There are two CANopen flash signs: RUN and ERR.

RUN LED:

LED status	Condition	CANopen State
OFF		Initial
Blinking		Pre-Operation
Single flash		Stopped
ON		Operation

ERR LED:

LED status	Condition/ State
OFF	No Error
Single flash	One Message fail
Double flash	Guarding fail or heartbeat fail
Triple flash	SYNC fail
ON	Bus off

Chapter 14 PLC Function

- 14-1 PLC Overview
- 14-2 Precautions for Using PLC
- 14-3 Start-up
- 14-4 PLC Ladder Diagram
- 14-5 PLC Devices
- 14-6 Commands
- 14-7 Error Code and Troubleshoot

14-1 PLC Overview

14-1-1 Introduction

The built in PLC function in C2000 allows following commands: WPLSoft, basic commands and application commands; the operation methods are the same as Delta DVPPLC series. Other than that, CANopen master provides 8 stations for synchronous control and 126 asynchronous controls.

NOTE

In C2000, CANopen master synchronous control complies with DS402 standard and supports homing mode, speed mode, torque mode and point to point control mode; CANopen slave supports two control modes, speed mode and torque mode.

14-1-2 Ladder Diagram Editor – WPLSoft

WPLSoft is a program editor of Delta DVP-PLC series and C200 series for WINDOWS. Besides general PLC program planning and general WINDOWS editing functions, such as cut, paste, copy, multi-windows, WPLSoft also provides various Chinese/English comment editing and other special functions (e.g. register editing, settings, the data readout, the file saving, and contacts monitor and set, etc.).

Following is the system requirement for WPLSoft:

Item	System Requirement
Operation System	Windows 95/98/2000/NT/ME/XP
Memory	Pentium 90 and above
Hard Disk	16MB and above (32MB and above is recommended)
Monitor	Capacity: 50MB and above CD-ROM (for installing WPLSoft)
Mouse	Resolution: 640×480, 16 colors and above, It is recommended to set display setting of Windows to 800×600.
Printer	General mouse or the device compatible with Windows
Memory	Printer with Windows driver
RS-485 port	At least one of COM1 to COM8 can be connected to PLC
Applicable Models	All Delta DVP-PLC series and C200 series

14-2 Precautions for Using PLC Functions

1. Default setting of PLC communication protocol is 8,N,2 ,19200, station number 2.
2. Host controller can read/write data from/to both the AC motor drive and the internal PLC program by setting the drive and internal PLC program to two different station numbers. For example, if user wants to set AC motor drive as station 1 and PLC as station 2, please write following setting to the host controller:
When setting 01(Station) 03(Read) 0400(Address) 0001(1 data), the host controller can read the Pr.04-00 from the AC motor drive.
When setting 02(Station) 03(Read) 0400(Address) 0001(1 data), host controller will read X0 data from the internal PLC program.
3. The internal PLC program will stop operation when upload/download programs.
4. When using WPR command to write parameters, parameters can be changed for a maximum of 10^9 times. It is crucial not to exceed this limit to prevent occurrence of serious error.
5. When Pr.00-04 is set to 28, D1043 value of PLC register will be displayed on the digital keypad:

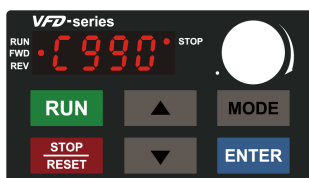

0 ~ 999 display:



1000 ~ 9999 display: It will only display the first 3 digits. The LED at the bottom-right corner will light to indicate 10 times of the display value. For example, the actual value for the following figure is $100 \times 10 = 1000$.



10000~65535 display: It will only display the first 3 digits. The LED at the bottom-right corner and the single decimal point between the middle and the right-most numbers will light to indicate 100 times of the display value. For example, the actual value for the following figure is $100 \times 100 = 10000$.

6. When PLC Stop mode, RS-485 is used by PLC.
7. When PLC is in PLC Run or PLC Stop mode, Pr.00-02 (settings 9 and 10) are disabled.
8. When Pr.00-02 is set to 6, PLC function settings will return to factory settings.
9. When the Input Terminal X of PLC is programmed, the corresponding MI will be disabled (no function).
10. When the input terminal Y0, Y1, Y3, Y4 of PLC is programmed, the corresponding RY1, RY2, DFM1, DFM2 will be disabled (no function).
11. When the analog output D1040, D1045 of PLC is programmed, the corresponding AFM1, AFM2 will be disabled (no function).
12. When PLC function is programmed with FREQ command, AC motor drive frequency is now under PLC function control. The setting of Pr.00-20 and Hand ON/OFF are disabled and has no control over AC motor drive frequency.
13. When PLC is programmed with TORQ command, AC motor drive torque is now under PLC function control. The setting of Pr.11-33 and Hand ON/OFF function are disabled and has no control over AC motor drive torque.

14-3 Start-up

14-3-1 The Steps for PLC Execution

Please operate PLC functions by following the steps indicate below:

When using KPC-CE01 series digital keypad, switch the mode to PLC2 for program download/upload:

- A. Press MODE key and select 'PLC'.
- B. Press 'UP' key and look for 'PLC2' then press 'ENTER'.
- C. If succeed, display 'END' for one to two seconds and return to 'PLC2' page.

The PLC warning that is displayed before program downloaded to C2000 can be ignored, please continue the operation.



1. Connection: Connect RJ-45 of AC motor drive to the computer by using RS485.

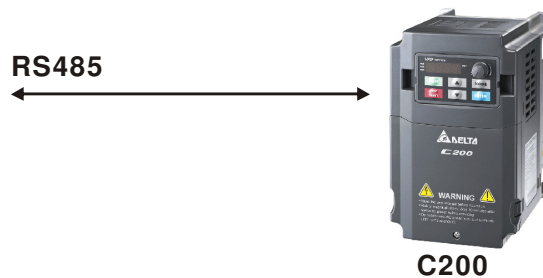

2. Run the program.

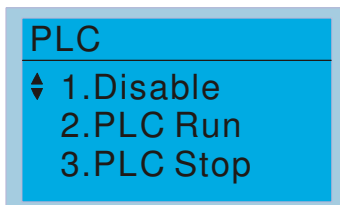

- PLC function, select function 2 (PLC Run).

- 1: Disable (PLC0)
- 2: PLC Run (PLC1)
- 3: PLC Stop (PLC2)

Optional accessories: Digital keypad KPC-CE01, display PLC function as shown in the ().

When external input terminals (MI1~MI8) are set to PLC Mode select bit0 (51) or PLC Mode select bit1 (52), it will force to switch to PLC mode regardless the terminal is ON or OFF. Meanwhile, switching via keypad is disabled. Please refer to the chart below:

PLC Mode	PLC Mode select bit1(52)	PLC Mode select bit0 (51)
Disable (PLC 0)	OFF	OFF
PLC Run (PLC 1)	OFF	ON
PLC Stop (PLC 2)	ON	OFF
Previous state	ON	ON

When KPE-LE02 execute PLC function:

1. When switching the page from PLC to PLC1, it will execute PLC. The motion of PLC (Execute/Stop) is controlled by WPL editor.
2. When switching the page from PLC to PLC2, it will stop PLC. Again the motion of PLC (Execute/Stop) is controlled by WPL editor.
3. The control of external terminals follows the same method.

 **NOTE**

When input/output terminals (FWD REV MI1~MI8 MI10~15, Relay1, Relay2 RY10~RY15, MO1~MO2 MO10~MO11,) are used in PLC program, they cannot be used in other places. For example, when PLC program (PLC1 or PLC2) is activated, such as when it controls Y0, the corresponding output terminals Relay (RA/RB/RC) will be used. At this moment, Pr.03.00 setting will be invalid since the terminal has been used by PLC. Refer to Pr.02-52, 02-53, 03-30 to check which DI DO AO are occupied by PLC.

14-3-2 I/O Device Reference Table

Input device:

Device	X0	X1	X2	X3	X4	X5	X6	X7	X10	X11	X12	X13	X14	X15	X16	X17
1	FWD	REV	MI1	MI2	MI3	MI4	MI5	MI6	MI7	MI8						

1: I/O extension card

Output device:

Device	Y0	Y1	Y2	Y3	Y4	Y5	Y6	Y7	Y10	Y11	Y12	Y13	Y14	Y15	Y16	Y17
1	RY1	RY2		DFM1	DFM2											

1: I/O extension card

14-3-3 WPLSoft Installation

Download PLC program to C200: Refer to D.3 to D.7 for program coding and download the editor (WPLSoft V2.09) at DELTA website <http://www.delta.com.tw/industrialautomation/>

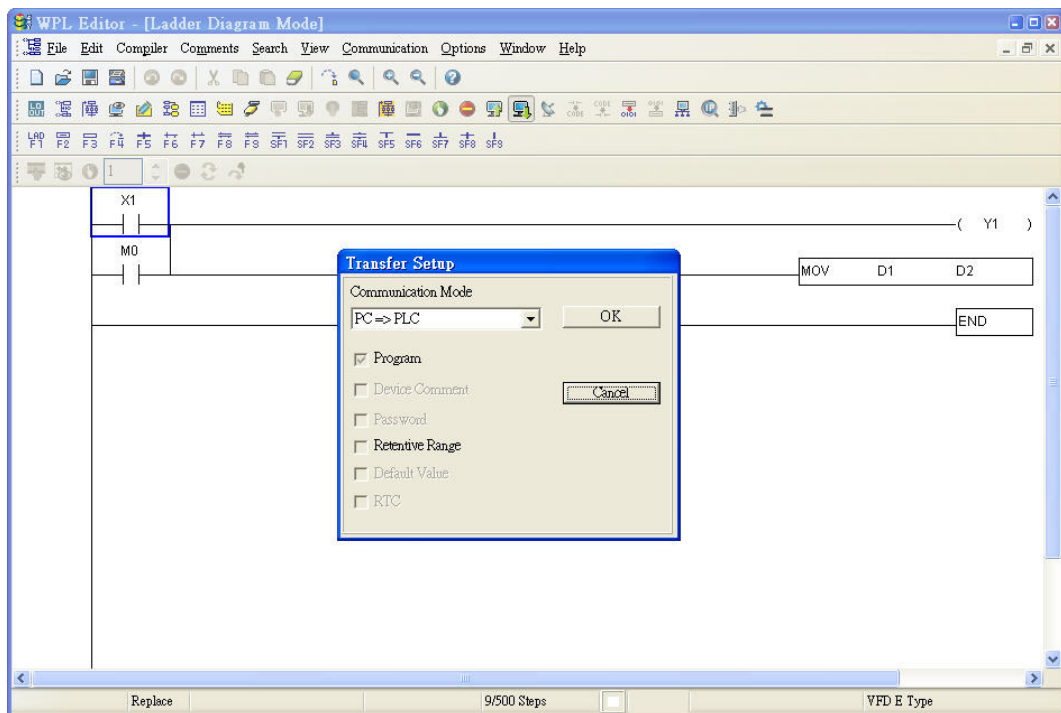

14-3-4 Program Input

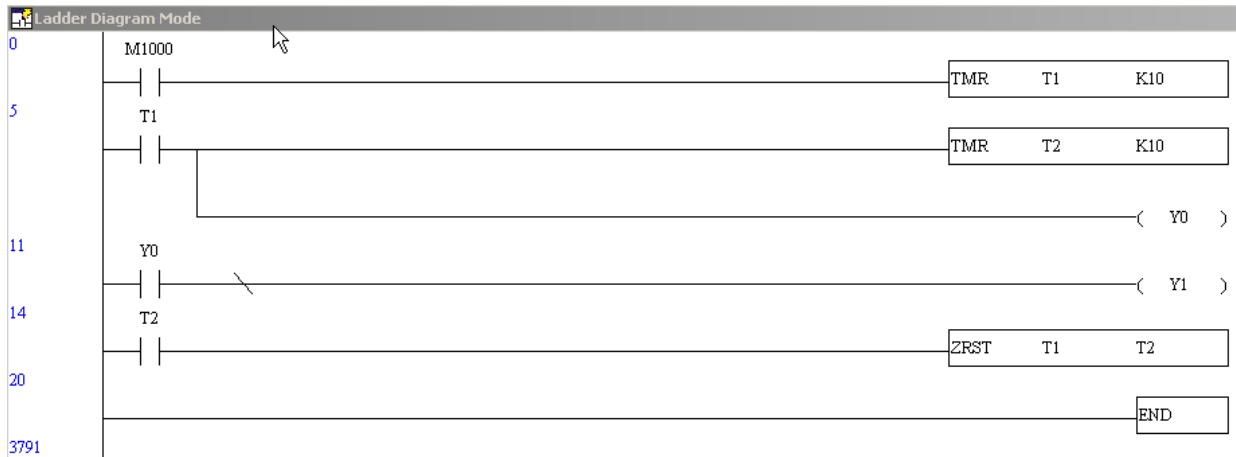

14-3-5 Program Download

Please download the program by following steps:

Step 1. Press  button for compiler after inputting program in WPLSoft.

Step 2. After compiler is finished, choose the item “Write to PLC” in the communication items.

After finishing Step 2, the program will be downloaded from WPLSoft to the AC motor drive by the communication format.

14-3-6 Program Monitor

If you execute “start monitor” in the communication item during executing PLC, the ladder diagram will be shown as follows.



14-4 Ladder Diagram

14-4-1 Program Scan Chart of the PLC Ladder Diagram

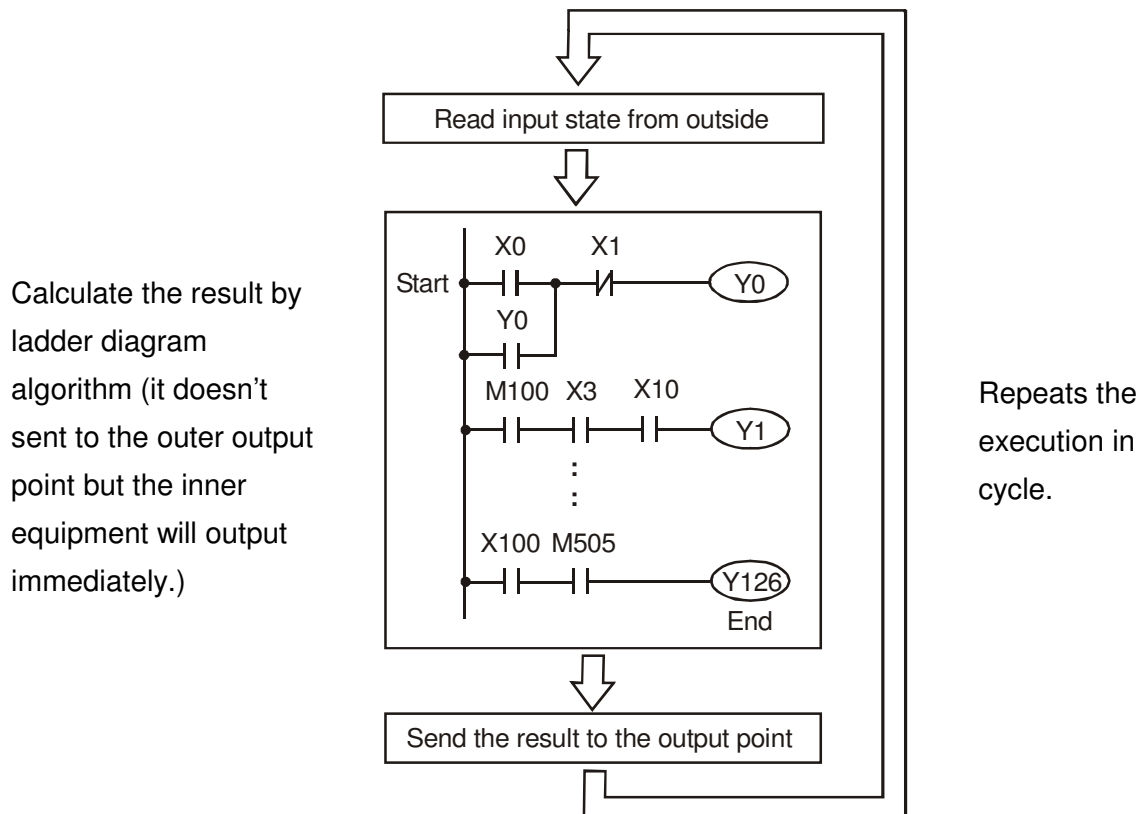

14-4-2 Ladder Diagram

Ladder diagram is a diagram language that applied on the automatic control and it is also a diagram that made up of the symbols of electric control circuit. PLC procedures are finished after ladder diagram editor edits the ladder diagram. It is easy to understand the control flow that indicated with diagram and also accept by technical staff of electric control circuit. Many basic symbols and motions of ladder diagram are the same as mechanical and electrical equipments of traditional automatic power panel, such as button, switch, relay, timer, counter and etc.

The kinds and amounts of PLC internal equipment will be different with brands. Although internal equipment has the name of traditional electric control circuit, such as relay, coil and contact. It doesn't have the real components in it. In PLC, it just has a basic unit of internal memory. If this bit is 1, it means the coil is ON and if this bit is 0, it means the coil is OFF. You should read the corresponding value of that bit when using contact (Normally Open, NO or contact a). Otherwise, you should read the opposite sate of corresponding value of that bit when using contact (Normally Closed, NC or contact b). Many relays will need many bits, such as 8-bits makes up a byte. 2 bytes can make up a word. 2 words make up double word. When using many relays to do calculation, such as add/subtraction or shift, you could use byte, word or double word. Furthermore, the two equipments, timer and counter, in PLC not only have coil but also value of counting time and times.

In conclusion, each internal storage unit occupies fixed storage unit. When using these equipments, the corresponding content will be read by bit, byte or word.

Brief introduction to the internal devices of PLC:

Internal Device	Function
Input Relay	<p>Input relay is the basic storage unit of internal memory that corresponds to external input point (it is the terminal that used to connect to external input switch and receive external input signal). Input signal from external will decide it to display 0 or 1. You couldn't change the state of input relay by program design or forced ON/OFF via WPLSoft. The contacts (contact a, b) can be used unlimitedly. If there is no input signal, the corresponding input relay could be empty and can't be used with other functions.</p> <p><input checked="" type="checkbox"/> Equipment indication method: X0, X1...X7, X10, X11... The symbol of equipment is X and numbering in octal.</p>
Output Relay	<p>Output relay is the basic storage unit of internal memory that corresponds to external output point (it is used to connect to external load). It can be driven by input relay contact, the contact of other internal equipment and itself contact. It uses a normally open contact to connect to external load and other contacts can be used unlimitedly as input contacts. It doesn't have the corresponding output relay, if need, it can be used as internal relay.</p> <p><input checked="" type="checkbox"/> Equipment indication: Y0, Y1...Y7, Y10, Y11... The symbol of equipment is Y and numbering in octal.</p>
Internal Relay	<p>The internal relay doesn't connect directly to outside. It is an auxiliary relay in PLC. Its function is the same as the auxiliary relay in electric control circuit. Each auxiliary relay has the corresponding basic unit. It can be driven by the contact of input relay, output relay or other internal equipment. Its contacts can be used unlimitedly. Internal auxiliary relay can't output directly, it should output with output point.</p> <p><input checked="" type="checkbox"/> Equipment indication: M0, M1...M799. The symbol of equipment is M and numbering in decimal system.</p>
Counter	<p>Counter is used to count. It needs to set counter before using counter (i.e. the pulse of counter). There are coil, contacts and storage unit of counter in counter. When coil is from OFF to ON, that means input a pulse in counter and the counter should add 1. There are 16-bit, 32-bit and high-speed counter for user to use.</p> <p><input checked="" type="checkbox"/> Equipment indication: C0, C1... C79. The symbol of equipment is C and numbering in decimal system.</p>
Timer	<p>Timer is used to control time. There are coil, contact and timer storage. When coil is ON, its contact will act (contact a is close, contact b is open) when attaining desired time. The time value of timer is set by settings and each timer has its regular period. User sets the timer value and each timer has its timing period. Once the coil is OFF, the contact won't act (contact a is open and contact b is close) and the timer will be set to zero.</p> <p><input checked="" type="checkbox"/> Equipment indication: T0, T1...T159. The symbol of equipment is T and numbering in decimal system. The different number range corresponds with the different timing period.</p>

Internal Device	Function
Data register	<p>PLC needs to handle data and operation when controlling each order, timer value and counter value. The data register is used to store data or parameters. It stores 16-bit binary number, i.e. a word, in each register. It uses two continuous number of data register to store double words.</p> <p><input checked="" type="checkbox"/> Equipment indication: D0, D1, ..., D399. The symbol of equipment is D and numbering in decimal system.</p>

The structure of ladder diagram and information:

Ladder Diagram Structure	Explanation	Command	Device
	Normally open, contact a	LD	X, Y, M, T, C
	Normally closed, contact b	LDI	X, Y, M, T, C
	Serial normally open	AND	X, Y, M, T, C
	Parallel normally open	OR	X, Y, M, T, C
	Parallel normally closed	ORI	X, Y, M, T, C
	Rising-edge trigger switch	LDP	X, Y, M, T, C
	Falling-edge trigger switch	LDF	X, Y, M, T, C
	Rising-edge trigger in serial	ANDP	X, Y, M, T, C
	Falling-edge trigger in serial	ANDF	X, Y, M, T, C
	Rising-edge trigger in parallel	ORP	X, Y, M, T, C
	Falling-edge trigger in parallel	ORF	X, Y, M, T, C
	Block in serial	ANB	none
	Block in parallel	ORB	none

Ladder Diagram Structure	Explanation	Command	Device
	Multiple output	MPS MRD MPP	none
	Output command of coil drive	OUT	Y, M
	Basic command, Application command	Basic command/ Application command	
	Inverse logic	INV	none

14-4-3 The Edition of PLC Ladder Diagram

The program edited method is from left power line to right power line. (The right power line will be omitted during the edited of WPLSoft.) After editing a row, go to editing the next row. The maximum contacts in a row are 11 contacts. If you need more than 11 contacts, you could have the new row and start with continuous line to continue more input devices. The continuous number will be produced automatically and the same input point can be used repeatedly. The drawing is shown as follows.

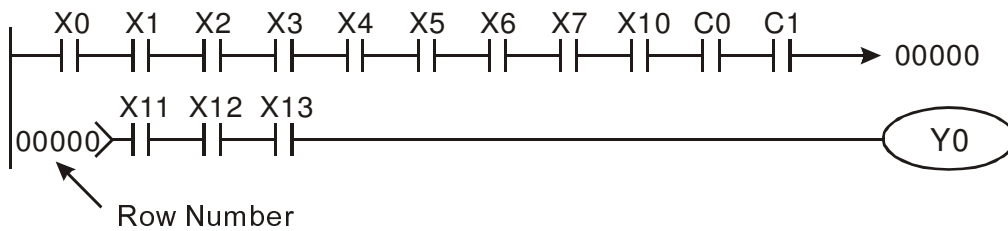

The operation of ladder diagram is to scan from left upper corner to right lower corner. The output handling, including the operation frame of coil and application command, at the most right side in ladder diagram.

Take the following diagram for example; we analyze the process step by step. The number at the right corner is the explanation order.

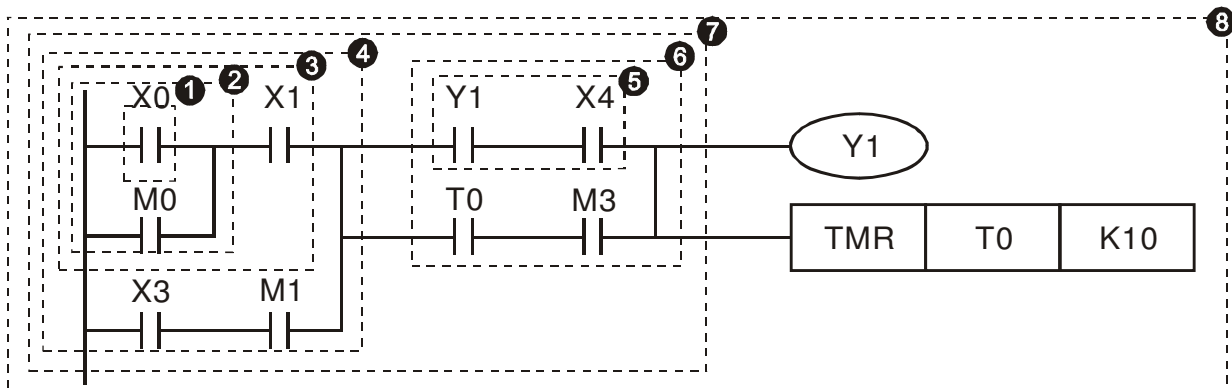

The explanation of command order:

- 1 LD X0
- 2 OR M0
- 3 AND X1
- 4 LD X3
- AND M1
- ORB

```

5      LD   Y1
      AND  X4

```

The explanation of command order:

```

6      LD   T0
      AND  M3
      ORB
7      ANB
8      OUT  Y1
      TMR  T0   K10

```

The detail explanation of basic structure of ladder diagram

1. **LD (LDI) command:** give the command LD or LDI in the start of a block.

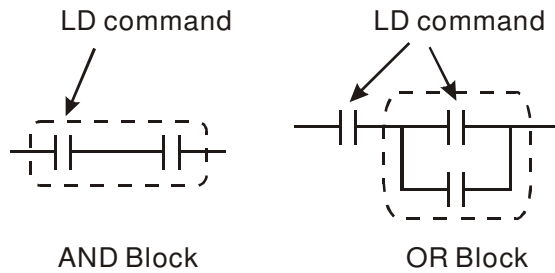

The structures of command LDP and LDF are similar to the command LD. The difference is that command LDP and LDF will act in the rising-edge or falling-edge when contact is ON as shown in the following.

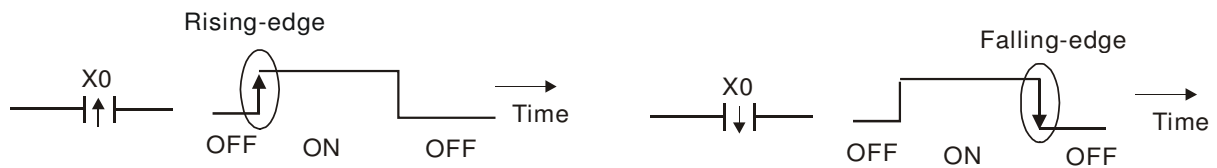

2. **AND (ANI) command:** single device connects to a device or a block in series.

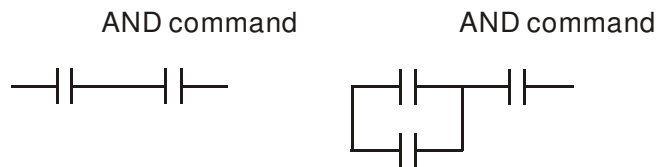

The structures of ANDP and ANDF are the same but the action is in rising-edge or falling-edge.

3. **OR (ORI) command:** single device connects to a device or a block.

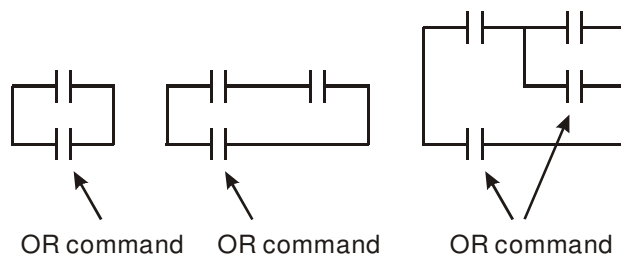

The structures of ORP and ORF are the same but the action is in rising-edge or falling-edge.

4. **ANB command:** a block connects to a device or a block in series.

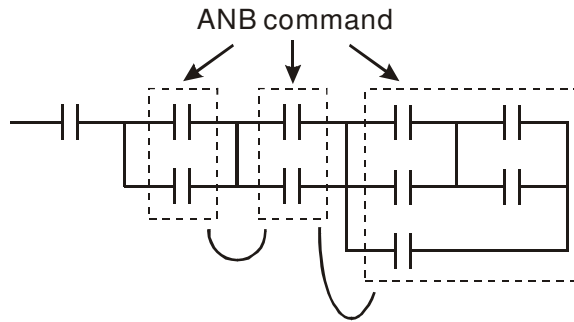

5. **ORB command:** a block connects to a device or a block in parallel.

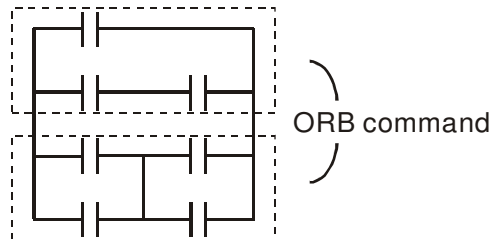

If there are several blocks when operate ANB or ORB, they should be combined to blocks or network from up to down or from left to right.

6. **MPS, MRD, MPP commands:** Divergent memory of multi-output. It can produce many various outputs.
7. The command MPS is the start of divergent point. The divergent point means the connection place between horizontal line and vertical line. We should determine to have contact memory command or not according to the contacts status in the same vertical line. Basically, each contact could have memory command but in some places of ladder diagram conversion will be omitted due to the PLC operation convenience and capacity limit. MPS command can be used for 8 continuous times and you can recognize this command by the symbol “┐”.
8. MRD command is used to read memory of divergent point. Because the logical status is the same in the same horizontal line, it needs to read the status of original contact to keep on analyzing other ladder diagram. You can recognize the command MRD by the symbol “┌”.
9. MPP command is used to read the start status of the top level and pop it out from stack. Because it is the last item of the horizontal line, it means the status of this horizontal line is ending.

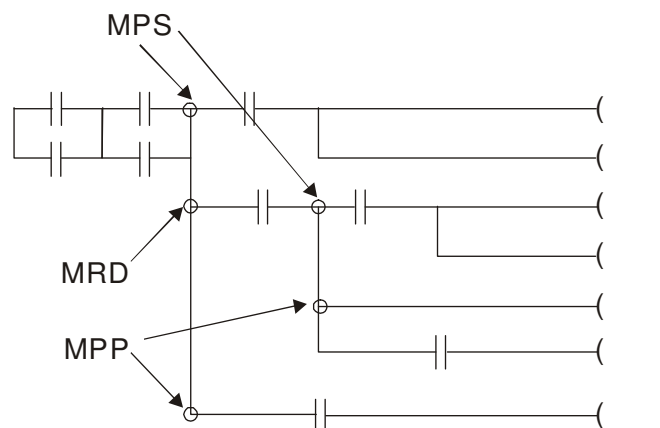

14-4-4 The Example for Designing Basic Program

Start, Stop and Latching

In the same occasions, it needs transient close button and transient open button to be start and stop switch. Therefore, if you want to keep the action, you should design latching circuit. There are several latching circuits in the following:

Example 1: the latching circuit for priority of stop

When start normally open contact X1=On, stop normally contact X2=Off, and Y1=On are set at the same time, if X2=On, the coil Y1 will stop acting. Therefore, it calls priority of stop.

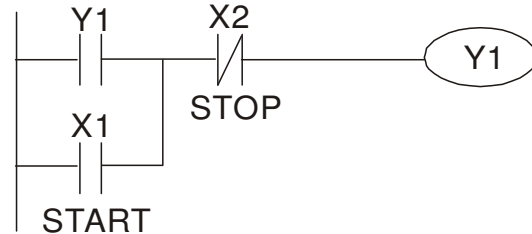

Example 2: the latching circuit for priority of start

When start normally open contact X1=On, stop normally contact X2=Off and Y1=On (coil Y1 will be active and latching) are valid at the same time, if X2=On, coil Y1 will be active due to latched contact. Therefore, it calls priority of start.

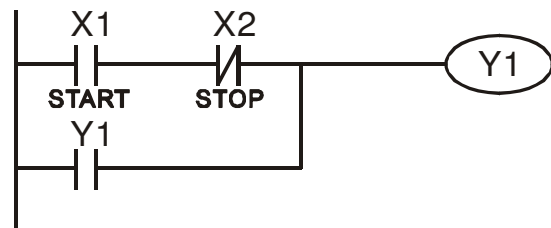

Example 3: the latching circuit of SET and RST commands

The figure at the right side is latching circuit that made up of RST and SET command. It is top priority of stop when RST command is set behind SET command. When executing PLC from up to down, The coil Y1 is ON and coil Y1 will be OFF when X1 and X2 act at the same time, therefore it calls priority of stop.

Top priority of stop

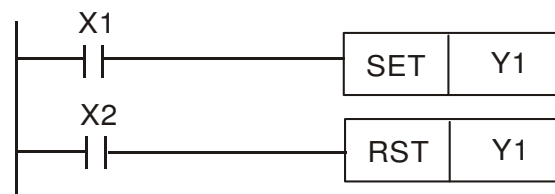

It is top priority of start when SET command is set after RST command. When X1 and X2 act at the same time, Y1 is ON so it calls top priority of start.

Top priority of start

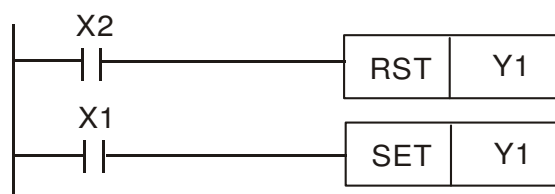

The common control circuit

Example 4: condition control

X1 and X3 can start/stop Y1 separately, X2 and X4 can start/stop Y2 separately and they are all self latched circuit. Y1 is an element for Y2 to do AND function due to the normally open contact connects to Y2 in series. Therefore, Y1 is the input of Y2 and Y2 is also the input of Y1.

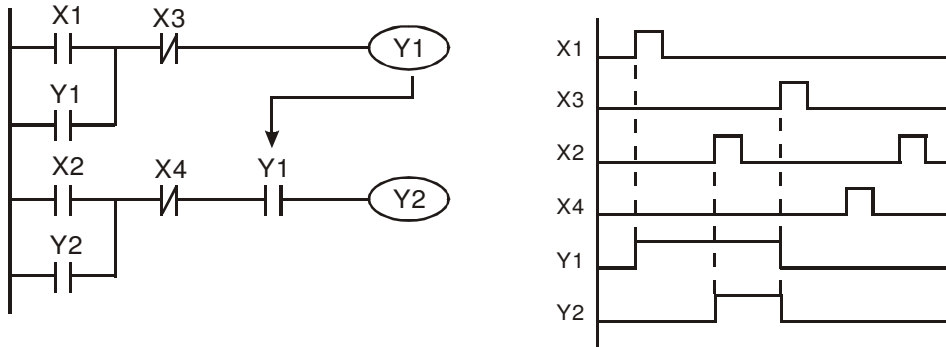

Example 5: Interlock control

The figure above is the circuit of interlock control. Y1 and Y2 will act according to the start contact X1 and X2. Y1 and Y2 will act not at the same time, once one of them acts and the other won't act. (This is called interlock.) Even if X1 and X2 are valid at the same time, Y1 and Y2 won't act at the same time due to up-to-down scan of ladder diagram. For this ladder diagram, Y1 has higher priority than Y2.

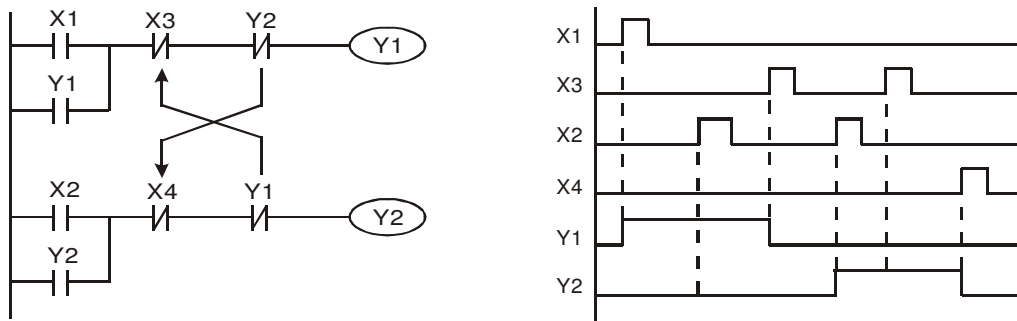

Example 6: Sequential Control

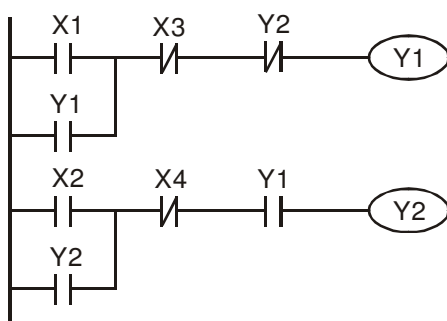

If add normally close contact Y2 into Y1 circuit to be an input for Y1 to do AND function. (as shown in the left side) Y1 is an input of Y2 and Y2 can stop Y1 after acting. In this way, Y1 and Y2 can execute in sequential.

Example 7: Oscillating Circuit

The period of oscillating circuit is $\Delta T + \Delta T$

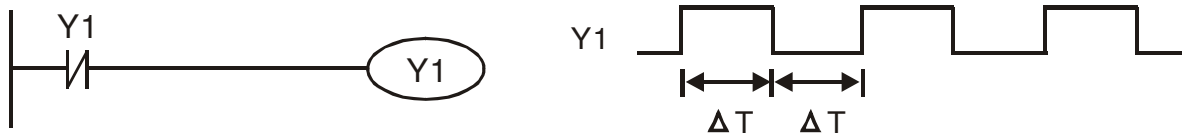

The figure above is a very simple ladder step diagram. When starting to scan Y1 normally close contact, Y1 normally close contact is close due to the coil Y1 is OFF. Then it will scan Y1 and the coil Y1 will be ON and output 1. In the next scan period to scan normally close contact Y1, Y1 normally close contact will be open due to Y1 is ON. Finally, coil Y1 will be OFF. The result of repeated scan, coil Y will output the vibrating pulse with cycle time ΔT (On) + ΔT (Off).

The vibrating circuitry of cycle time ΔT (On) + ΔT (Off):

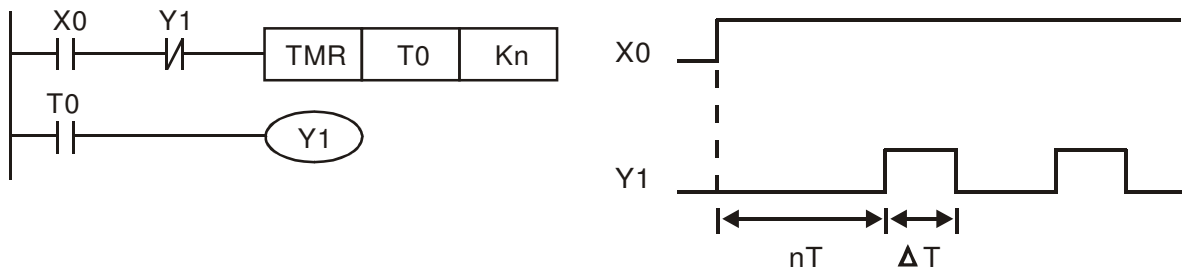

The figure above uses timer T0 to control coil Y1 to be ON. After Y1 is ON, timer T0 will be closed at the next scan period and output Y1. The oscillating circuit will be shown as above. (n is the setting of timer and it is decimal number. T is the base of timer. (clock period))

Example 8: Blinking Circuit

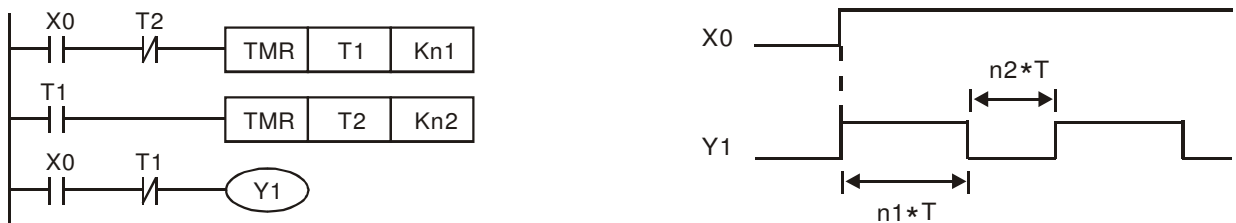

The figure above is common used oscillating circuit for indication light blinks or buzzer alarms. It uses two timers to control On/OFF time of Y1 coil. If figure, n1 and n2 are timer setting of T1 and T2. T is the base of timer (clock period)

Example 9: Triggered Circuit

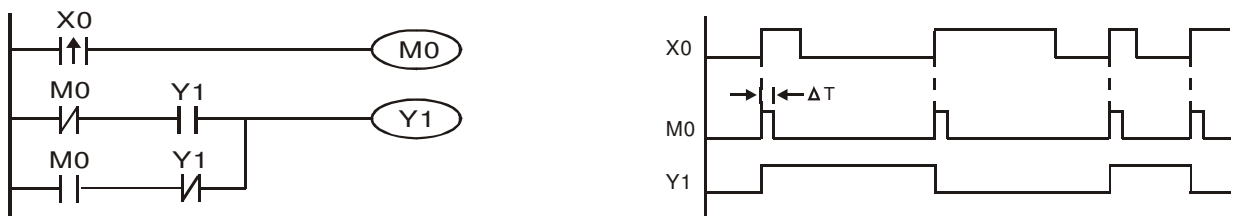

In figure above, the rising-edge differential command of X0 will make coil M0 to have a single pulse of ΔT (a scan time). Y1 will be ON during this scan time. In the next scan time, coil M0 will be OFF, normally close M0 and normally close Y1 are all closed. However, coil Y1 will keep on being ON and it will make coil Y1 to be OFF once a rising-edge comes after input X0 and coil M0 is ON for a scan time. The timing chart is as shown above. This circuit usually executes alternate two actions with an input. From above timing: when input X0 is a square wave of a period T, output coil Y1 is square wave of a period 2T.

Example 10: Delay Circuit

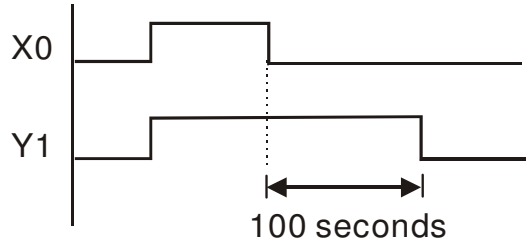
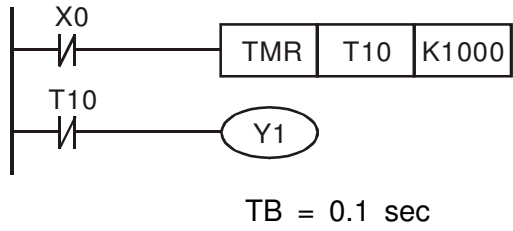

When input X0 is ON, output coil Y1 will be ON at the same time due to the corresponding normally close contact OFF makes timer T10 to be OFF. Output coil Y1 will be OFF after delaying 100 seconds ($K1000 \times 0.1 \text{ seconds} = 100 \text{ seconds}$) once input X0 is OFF and T10 is ON. Please refer to timing chart above.

Example 11: Output delay circuit, in the following example, the circuit is made up of two timers.

No matter input X0 is ON or OFF, output Y4 will be delay.

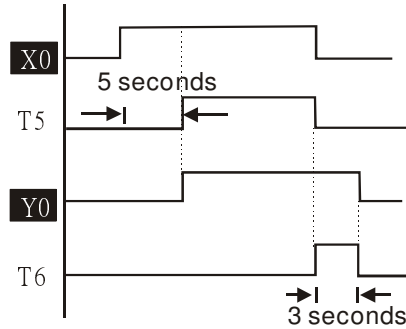
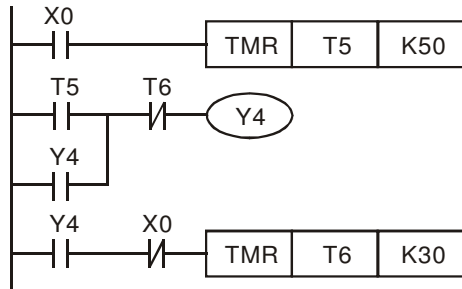

Example 12: Extend Timer Circuit

In this circuit, the total delay time from input X0 is close and output Y1 is ON = $(n1+n2) \times T$. where T is clock period. Timer: T11, T12; Timer cycle: T.

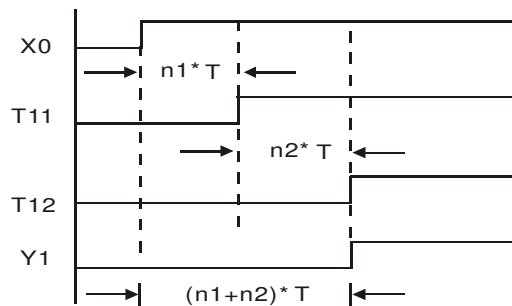
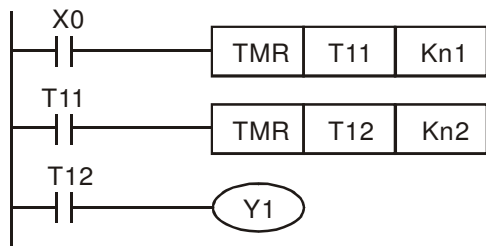

14-5 PLC Devices Function

Items	Specifications	Remarks
Control Method	Stored program, cyclic scan system	
I/O Processing Method	Batch processing (when END instruction is executed)	I/O refresh instruction is available
Execution Speed	Basic commands (minimum 0.24 us)	Application commands (1 ~ dozens us)
Program Language	Instruction, Ladder Logic, SFC	
Program Capacity	5000 STEPS	
Commands	80 commands	30 basic commands 50 application commands
Input/Output Contact	Input (X): 10, output (Y): 4	

	Device	Item	Range	Function	
Relay [bit mode]	X	External Input Relay	X0~X17, 16 points, octal number system	Total is 32 points Correspond to external input point	
	Y	External Output Relay	Y0~Y17, 16 points, octal number system		Correspond to external output point
	M	Auxiliary	For general	M0~M799, 800 points	Total is 192 points Contacts can switch to On/Off in program
			For special	M1000~M1079, 80 points	
	T	Timer	100ms timer	T0~T159, 160 points	Total is 16 points When the timer indicated by TMR command attains the setting, the T contact with the same number will be On.
C	Counter	16-bit count up for general	C0~C79, 80 points	Total is 80 points When the counter indicated by CNT command attains the setting, the C contact with the same number will be On.	
Register [WORD data]	T	Present value of timer	T0~T15, 160 points	When timer attains, the contact of timer will be On.	
	C	Present value of counter	C0~C79, 16-bit counter, 80 points	When timer attains, the contact of timer will be On.	
	D	Data register	For latched	D0~D399, 400 points	Total is 1300 points It can be memory area for storing data.
For general			D1000~D1099, 100 points		
For special			D2000~D2799, 800 points		
Constant	K	Decimal	K-32,768 ~ K32,767 (16-bit operation)		
	H	Hexadecimal	H0000 ~ HFFFF (16-bit operation)		
Communication port (program read/write)			RS485 (slave)		
Analog input/output			Built-in 2 analog inputs and 1 analog output		
Function extension module (optional)			EMC-D42A; EMC-R6AA; EMCD611A		

14-5-1 Devices Functions

The Function of Input/output Contacts

The function of input contact X: input contact X reads input signal and enter PLC by connecting with input equipment. It is unlimited usage times for contact A or contact B of each input contact X in program. The On/Off of input contact X can be changed with the On/Off of input equipment but can't be changed by using peripheral equipment (WPLSoft).

The Function of Output Contact Y

The mission of output contact Y is to drive the load that connects to output contact Y by sending On/Off signal. There are two kinds of output contact: one is relay and the other is transistor. It is unlimited usage times for A or B contact of each output contact Y in program. But there is number for output coil Y and it is recommended to use one time in program. Otherwise, the output result will be decided by the circuit of last output Y with PLC program scan method.

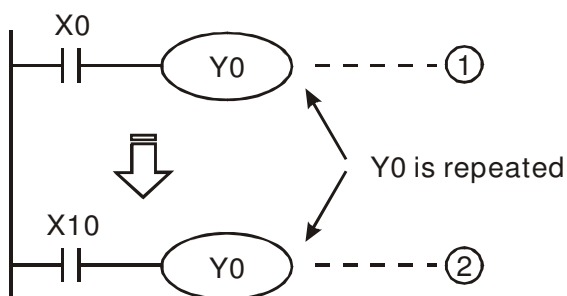

The output of Y0 will be decided by circuit 2, i.e. decided by On/Off of X10.

Value, Constant [K] / [H]

Constant	K	Decimal	K-32,768 ~ K32,767 (16-bit operation)
	H	Hexadecimal	H0000 ~ HFFFF (16-bit operation)

There are five value types for DVP-PLC to use by the different control destination. The following is the explanation of value types.

Binary Number (BIN)

It uses binary system for the PLC internal operation or storage. The relative information of binary system is in the following.

Bit	Bit is the basic unit of binary system, the status are 1 or 0.
Nibble	It is made up of continuous 4 bits, such as b3~b0. It can be used to represent number 0~9 of decimal or 0~F of hexadecimal.
Byte	It is made up of continuous 2 nibbles, i.e. 8 bits, b7~b0. It can used to represent 00~FF of hexadecimal system.
Word	It is made up of continuous 2 bytes, i.e. 16-bit, b15~b0. It can used to represent 0000~FFFF of hexadecimal system.
Double Word	It is made up of continuous 2 words, i.e. 32-bit, b31~b0. It can used to represent 00000000~FFFFFFFF of hexadecimal system.

The relations among bit, nibble, byte, word, and double word of binary number are shown as follows.

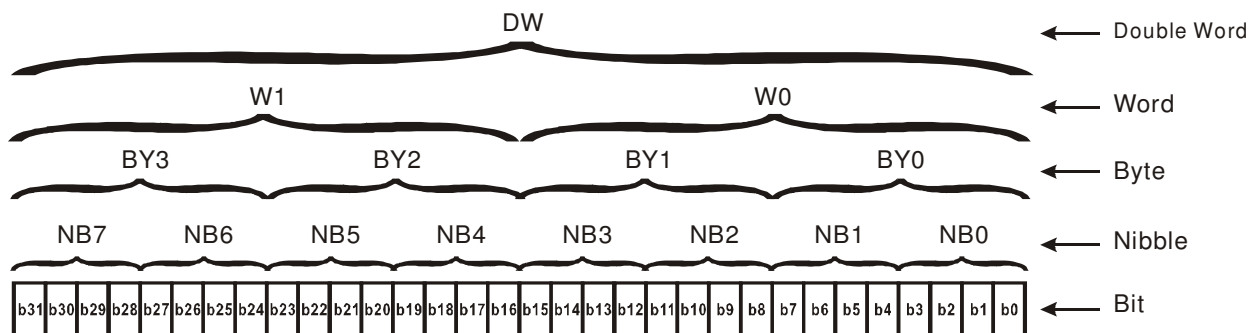

➤ Octal Number (OCT)

The numbers of external input and output terminal of DVP-PLC use octal number.

Example:

External input: X0~X7, X10~X17... (device number)

External output: Y0~Y7, Y10~Y17... (device number)

➤ Decimal Number, DEC

The suitable time for decimal number to be used in DVP-PLC system.

- To be the setting value of timer T or counter C, such as TMR C0 K50. (K constant)
- To be the device number of M, T, C and D. For example: M10, T30. (device number)
- To be operand in application command, such as MOV K123 D0. (K constant)

➤ Binary Code Decimal (BCD)

It shows a decimal number by a unit number or four bits so continuous 16-bit can use to represent the four numbers of decimal number. BCD code is usually used to read the input value of DIP switch or output value to 7-segment display to be display.

➤ Hexadecimal Number (HEX)

The suitable time for hexadecimal number to be used in DVP-PLC system.

- To be operand in application command. For example: MOV H1A2B D0. (constant H)

➤ Constant K:

In PLC, it is usually have K before constant to mean decimal number. For example, K100 means 100 in decimal number.

Exception: The value that is made up of K and bit equipment X, Y, M, S will be bit, byte, word or double word. For example, K2Y10, K4M100. K1 means a 4-bit data and K2~K4 can be 8, 12 and 16-bit data separately.

➤ Constant H:

In PLC, it is usually have H before constant to mean hexadecimal number. For example, H100 means 100 in hexadecimal number.

The Function of Auxiliary Relay

There are output coil and A, B contacts in auxiliary relay M and output relay Y. It is unlimited usage times in program. User can control loop by using auxiliary relay, but can't drive external load directly. There are two types divided by its characteristics.

1. Auxiliary relay for general : It will reset to Off when power loss during running. Its state will be Off when power on after power loss.
2. Auxiliary relay for special : Each special auxiliary relay has its special function. Please don't use undefined auxiliary relay.

The Function of Timer

The unit of timer is 1ms, 10ms and 100ms. The count method is count up. The output coil will be On when the present value of timer equals to the settings. The setting is K in decimal number. Data register D can be also used as settings.

- The real setting time of timer = unit of timer * settings

The Features and Functions of Counter

Item	16-bit counters	32-bit counters	
Type	General	General	High speed
Count direction	Count up	Count up/down	
Settings	0~32,767	-2,147,483,648~+2,147,483,647	
Designate for constant	Constant K or data register D	Constant K or data register D (2 for designated)	
Present value change	Counter will stop when attaining settings	Counter will keep on counting when attaining settings	
Output contact	When count attains the settings value, contact will be On and latched.	When count up attains settings, contact will be On and latched. When count down attains settings, contact will reset to Off.	
Reset action	The present value will reset to 0 when RST command is executed and contact will reset to Off.		
Present register	16-bit	32-bit	
Contact action	After scanning, act together.	After scanning, act together. Act immediately when count attains. It has no relation with scan period.	

Functions:

When pulse input signal of counter is from Off to On, the present value of counter equals to settings and output coil is On. Settings are decimal system and data register D can also be used as settings.

16-bit counters C0~C79:

- Setting range of 16-bit counter is K0~K32,767. (K0 is the same as K1. output contact will be On immediately at the first count.
- General counter will be clear when PLC is power loss. If counter is latched, it will remember the value before power loss and keep on counting when power on after power loss.
- If using MOV command, WPLSoft to send a value, which is large than setting to C0, register, at the next time that X1 is from Off to On, C0 counter contact will be On and present value will be set to the same as settings.
- The setting of counter can use constant K or register D (not includes special data register D1000~D1044) to be indirect setting.

- ☑ If using constant K to be setting, it can only be positive number but if setting is data register D, it can be positive/negative number. The next number that counter counts up from 32,767 is -32,768.

Example:

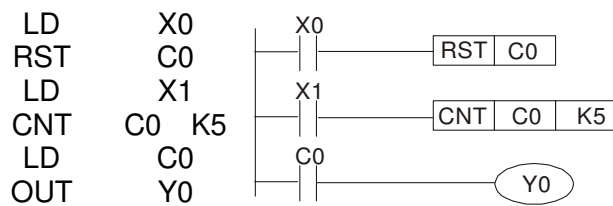

1. When X0=On, RST command is executed, C0 reset to 0 and output contact reset to Off.
2. When X1 is from Off to On, counter will count up (add 1).
3. When counter C0 attains settings K5, C0 contact is On and C0 = setting =K5. C0 won't accept X1 trigger signal and C0 remains K5.

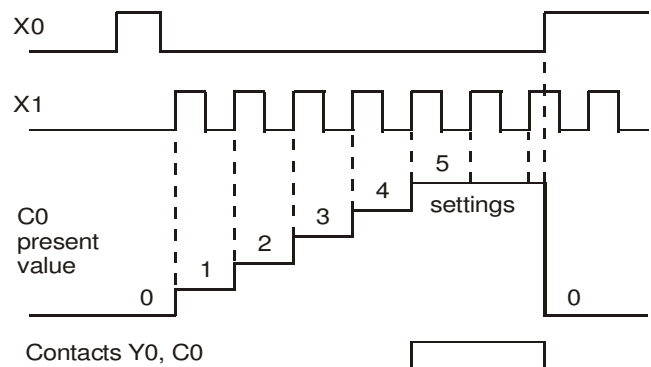

14-5-2 Special Auxiliary Relays

Special M	Function	Read(R)/Write(W)
M1000	Normally open contact (a contact). This contact is On when running and it is On when the status is set to RUN.	Read only
M1001	Normally closed contact (b contact). This contact is Off when running and it is Off when the status is set to RUN.	Read only
M1002	On only for 1 scan after RUN. Initial pulse is contact a. It will get positive pulse in the RUN moment. Pulse width=scan period.	Read only
M1003	Off only for 1 scan after RUN. Initial pulse is contact a. It will get negative pulse in the RUN moment. Pulse width=scan period.	Read only
M1004	Reserved	-
M1005	Fault indication of the AC motor drives	Read only
M1006	Output frequency is 0, M1006 On	Read only
M1007	Operation direction of AC motor drives (FWD: M1007 Off, REV: M1007On)	Read only
M1008 ~ M1010	Reserved	-
M1011	10ms clock pulse, 5ms On/5ms Off	Read only
M1012	100ms clock pulse, 50ms On / 50ms Off	Read only
M1013	1s clock pulse, 0.5s On / 0.5s Off	Read only
M1014	1min clock pulse, 30s On / 30s Off	Read only
M1015	Frequency attained, M1015=On	Read only
M1016	Parameter read/write error, M1016=On	Read only
M1017	Succeed to write parameter, M1017 =On	Read only
M1018	Reserved	

Special M	Function	Read(R)/Write(W)
M1019	Reserved	
M1020	Zero flag	Read only
M1021	Borrow flag	Read only
M1022	Carry flag	Read only
M1023	Divisor is 0	Read only
M1024	Reserved	-
M1025	RUN(ON) / STOP(OFF) the AC motor drive	Read/Write
M1026	The operation direction of the AC motor drive (FWD: OFF, REV: ON)	Read/Write
M1027	AC motor drive reset	Read/Write
M1028 ~ M1039	Reserved	-
M1040	Power On	Read/Write
M1041	Reserved	-
M1042	Quick stop	Read/Write
M1043	Reserved	-
M1044	Halt	Read/Write
M1045 ~ M1051	Reserved	-
M1052	Frequency Lock	Read/Write
M1053 ~ M1055	Reserved	-
M1056	Power on ready	Read only
M1057	Reserved	-
M1058	On quick stopping	Read only
M1059 ~ M1062	Reserved	-
M1063	Target torque attained	Read only
M1064 ~ M1071	Reserved	Read only
M1072 ~ M1079	Reserved	Read/Write
M1073 ~ M1079	Reserved	Read only

14-5-3 Special Registers

Special D	Function	Read(R)/Write(W)
D1000	Reserved	-
D1001	PLC firmware version	Read only

Special D	Function	Read(R)/Write(W)
D1002	Program capacity	Read only
D1003	Checksum	Read only
D1004 ~ D1009	Reserved	-
D1010	Present scan time (Unit: 0.1ms)	Read only
D1011	Minimum scan time (Unit: 0.1ms)	Read only
D1012	Maximum scan time (Unit: 0.1ms)	Read only
D1013 ~ D1019	Reserved	-
D1020	Output frequency (0.000~600.00Hz)	Read only
D1021	Output current (####.#A)	Read only
D1022 ~ D1026	Reserved	-
D1027	Frequency command of the PID control	Read only
D1028	The responsive value of AUI AVI (analog voltage input) (0.00~100.00%)	Read only
D1029	The responsive value of AUI ACI (analog current input) (0.0~100.00%)	Read only
D1030	The corresponding value for AUI (-100.0~100.00%)	Read only
D1031 ~ D1035	Reserved	-
D1036	AC motor drive error code	Read only
D1037	AC motor drive output frequency	Read only
D1038	DC Bus voltage	Read only
D1039	Output voltage	Read only
D1040	Analog output value AFM1 (-100.00~100.00%)	Read/Write
D1041 ~ D1042	Reserved	-
D1043	User defined (When Pr.00.04 is set to 28, the register data will be displayed as C xxx)	Read/Write
D1044	Reserved	-
D1045	Analog output value AFM2 (-100.00~100.00%)	Read/Write
D1046 ~ D1049	Reserved	-
D1050	Actual mode 0: Velocity mode 1: Position mode 2: Torque mode	Read only
+D1051 ~ D1052	Reserved	-
D1053	Actual torque	Read only
D1054 ~ D1059	Reserved	Read only

Special D	Function	Read(R)/ Write(W)
D1060	Mode setting 0: Speed Mode 2: Torque Mode	Read/Write
D1061 ~ D1069	Reserved	Read/Write

14-5-4 Communication Address for PLC Devices

Device	Range	Type	Address (Hex)
X	00~17 (Octal)	bit	0400~040F
Y	00~17 (Octal)	bit	0500~050F
T	00~159	bit/word	0600~069F
M	000~799	bit	0800~0B1F
M	1000~1079	bit	0BE8~0C37
C	0~79	bit/word	0E00~0E47
D	00~399	word	1000~118F
D	1000~1099	word	13E8~144B

Function Code

Function Code	Description	Supported Devices
01	Read coil status	Y, M, T, C
02	Read input status	X,Y,M,T,C
03	Read one data	T,C,D
05	Force changing one coil status	Y,M,T,C
06	Write in one data	T,C,D
0F	Force changing multiple coil status	Y,M,T,C
10	Write in multiple data	T,C,D

Only when PLC is at Stop status, PLC data can be read/write via communication device. When PLC is at Run status, the communication address should be the mapping address, e.g. for Pr.04-00 it maps to 0400H.

NOTE

When PLC function is activated, C2000 can Read/Write the PLC and drive's parameter by different addresses (pre-defined station number for the AC motor drive is 1, for PLC station number is 2)

14-6 Commands

14-6-1 Basic Commands

Commands

Commands	Function	Operands
LD	Load contact A	X, Y, M, T, C
LDI	Load contact B	X, Y, M, T, C
AND	Series connection with A contact	X, Y, M, T, C
ANI	Series connection with B contact	X, Y, M, T, C
OR	Parallel connection with A contact	X, Y, M, T, C
ORI	Parallel connection with B contact	X, Y, M, T, C
ANB	Series connects the circuit block	--
ORB	Parallel connects the circuit block	--
MPS	Save the operation result	--
MRD	Read the operation result (the pointer is not moving)	--
MPP	Read the result	--

Output Command

Commands	Function	Operands
OUT	Drive coil	Y, M
SET	Action latched (ON)	Y, M
RST	Clear the contacts or the registers	Y, M, T, C, D

Timer and Counter

Commands	Function	Operands
TMR	16-bit timer	T-K or T-D
CNT	16-bit counter	C-K or C-D (16 bit)

Main Control Command

Commands	Function	Operands
MC	Connect the common series connection contacts	N0~N7
MCR	Disconnect the common series connection contacts	N0~N7

Rising-edge/falling-edge Detection Commands of Contact

Commands	Function	Operands
LDP	Rising-edge detection operation starts	X, Y, M, T, C
LDF	Falling-edge detection operation starts	X, Y, M, T, C
ANDP	Rising-edge detection series connection	X, Y, M, T, C
ANDF	Falling-edge detection series connection	X, Y, M, T, C
ORP	Rising-edge detection parallel connection	X, Y, M, T, C
ORF	Falling-edge detection parallel connection	X, Y, M, T, C

Rising-edge/falling-edge Output Commands

Commands	Function	Operands
PLS	Rising-edge output	Y, M
PLF	Falling-edge output	Y, M

End Command

Commands	Function	Operands
END	Program end	--

Other Command

Commands	Function	Operands
NOP	No function	--
INV	Inverse operation result	--
P	Indicator	P

14-6-2 Explanation for the Command

Mnemonic	Function					
LD	Load A contact					
Operand	X0~X17	Y0~Y17	M0~M799	T0~159	C0~C79	D0~D399
	✓	✓	✓	✓	✓	—

L The LD command is used on the A contact that has its start from the left BUS or the A contact that is the start of a contact circuit. Function of the command is to save present contents, and at the same time, save the acquired contact status into the accumulative register.

Explanation

Example

Ladder diagram



Command code Operation

LD	X0	Load contact A of X0
AND	X1	Connect to contact A of X1 in series
OUT	Y1	Drive Y1 coil

Mnemonic	Function					
LDI	Load B contact					
Operand	X0~X17	Y0~Y17	M0~M799	T0~159	C0~C79	D0~D399
	✓	✓	✓	✓	✓	—

The LDI command is used on the B contact that has its start from the left BUS or the B contact that is the start of a contact circuit. Function of the command is to save present contents, and at the same time, save the acquired contact status into the accumulative register.

Explanation

Example

Ladder diagram:



Command code: Operation:

LDI	X0	Load contact B of X0
AND	X1	Connect to contact A of X1 in series
OUT	Y1	Drive Y1 coil

Mnemonic	Function					
AND	Series connection- A contact					
Operand	X0~X17	Y0~Y17	M0~M799	T0~159	C0~C79	D0~D399
	✓	✓	✓	✓	✓	—

The AND command is used in the series connection of A contact. The function of the command is to readout the status of present specific series connection contacts first, and then to perform the “AND” calculation with the logic calculation result before the contacts, thereafter, saving the result into the accumulative register.

Explanation**Example**

Ladder diagram:



Command code: Operation:

LDI	X1	Load contact B of X1
AND	X0	Connect to contact A of X0 in series
OUT	Y1	Drive Y1 coil

Mnemonic	Function					
ANI	Series connection- B contact					
Operand	X0~X17	Y0~Y17	M0~M799	T0~159	C0~C79	D0~D399
	✓	✓	✓	✓	✓	—

The ANI command is used in the series connection of B contact. The function of the command is to readout the status of present specific series connection contacts first, and then to perform the “AND” calculation with the logic calculation result before the contacts, thereafter, saving the result into the accumulative register.

Explanation**Example**

Ladder diagram:



Command code: Operation:

LD	X1	Load contact A of X1
ANI	X0	Connect to contact B of X0 in series
OUT	Y1	Drive Y1 coil

Mnemonic	Function					
OR	Parallel connection- A contact					
Operand	X0~X17	Y0~Y17	M0~M799	T0~159	C0~C79	D0~D399
	✓	✓	✓	✓	✓	—

The OR command is used in the parallel connection of A contact. The function of the command is to readout the status of present specific series connection contacts, and then to perform the “OR” calculations with the logic calculation result before the contacts, thereafter, saving the result into the accumulative register.

Explanation

Ladder diagram:

Command code: Operation:

LD	X0	Load contact A of X0
----	----	----------------------

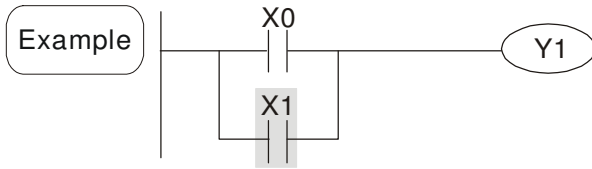

OR	X1	Connect to contact A of X1 in parallel
OUT	Y1	Drive Y1 coil

Mnemonic	Function					
ORI	Parallel connection- B contact					
Operand	X0~X17	Y0~Y17	M0~M799	T0~159	C0~C79	D0~D399
	✓	✓	✓	✓	✓	—

The ORI command is used in the parallel connection of B contact. The function of the command is to readout the status of present specific series connection contacts, and then to perform the “OR” calculations with the logic calculation result before the contacts, thereafter, saving the result into the accumulative register.

Explanation

Example

Ladder diagram:

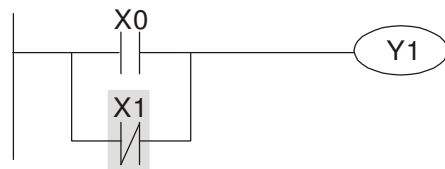

Command code: Operation:

LD	X0	Load contact A of X0
ORI	X1	Connect to contact B of X1 in parallel
OUT	Y1	Drive Y1 coil

Mnemonic	Function
ANB	Series connection (Multiple Circuits)
Operand	None

Explanation

To perform the “ANB” calculation between the previous reserved logic results and contents of the accumulative register.

Example

Ladder diagram:

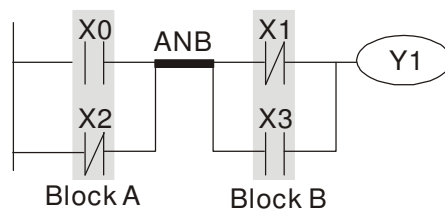

Command code: Operation:

LD	X0	Load contact A of X0
ORI	X2	Connect to contact B of X2 in parallel
LDI	X1	Load contact B of X1
OR	X3	Connect to contact A of X3 in parallel
ANB		Connect circuit block in series
OUT	Y1	Drive Y1 coil

Mnemonic	Function
ORB	Parallel connection (Multiple circuits)
Operand	None

Explanation

ORB is to perform the “OR” calculation between the previous reserved logic results and contents of the accumulative register.

Example

Ladder diagram:

Command code: Operation:

LD	X0	Load contact A of X0
-----------	-----------	----------------------

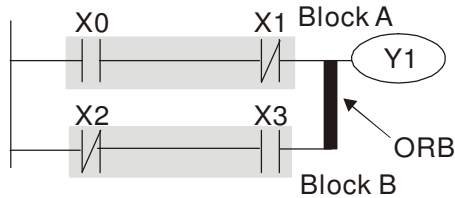

ANI	X1	Connect to contact B of X1 in series
LDI	X2	Load contact B of X2
AND	X3	Connect to contact A of X3 in series
ORB		Connect circuit block in parallel
OUT	Y1	Drive Y1 coil

Mnemonic	Function
MPS	Store the current result of the internal PLC operations
Operand	None

Explanation To save contents of the accumulative register into the operation result. (the result operation pointer plus 1)

Mnemonic	Function
MRD	Reads the current result of the internal PLC operations
Operand	None

Explanation Reading content of the operation result to the accumulative register. (the pointer of operation result doesn't move)

Mnemonic	Function
MPP	Reads the current result of the internal PLC operations
Operand	None

Explanation Reading content of the operation result to the accumulative register. (the stack pointer will decrease 1)

Example Ladder diagram:

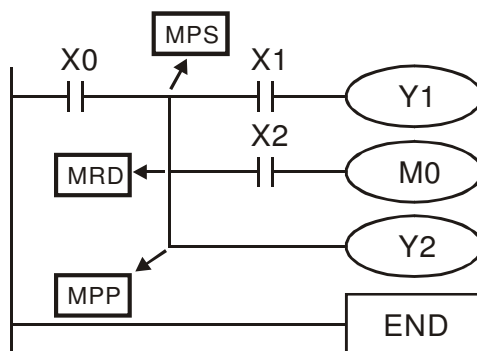

Command code: Operation:

LD	X0	Load contact A of X0
MPS		Save in stack
AND	X1	Connect to contact A of X1 in series
OUT	Y1	Drive Y1 coil
MRD		Read from the stack (without moving pointer)
AND	X2	Connect to contact A of X2 in series
OUT	M0	Drive M0 coil
MPP		Read from the stack
OUT	Y2	Drive Y2 coil
END		End program

Mnemonic	Function					
OUT	Output coil					
Operand	X0~X17	Y0~Y17	M0~M799	T0~159	C0~C79	D0~D399
	—	✓	✓	—	—	—

Explanation

Output the logic calculation result before the OUT command to specific device.

Motion of coil contact:

Operation result	OUT command		
	Coil	Contact	
		A contact (normally open)	B contact (normally closed)
FALSE	Off	Non-continuity	Continuity
TRUE	On	Continuity	Non-continuity

Example

Ladder diagram:

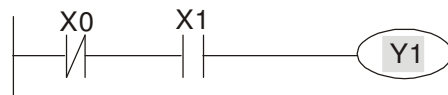

Command code: Operation:

LD	X0	Load contact B of X0
AND	X1	Connect to contact A of X1 in series
OUT	Y1	Drive Y1 coil

Mnemonic	Function					
SET	Latch (ON)					
Operand	X0~X17	Y0~Y17	M0~M799	T0~159	C0~C79	D0~D399
	—	✓	✓	—	—	—

Explanation

When the SET command is driven, its specific device is set to be “ON,” which will keep “ON” whether the SET command is still driven. You can use the RST command to set the device to “OFF”.

Example

Ladder diagram:



Command code: Operation:

LD	X0	Load contact A of X0
AN	Y0	Connect to contact B of Y0 in series
SET	Y1	Y1 latch (ON)

Mnemonic	Function					
RST	Clear the contacts or the registers					
Operand	X0~X17	Y0~Y17	M0~M799	T0~159	C0~C79	D0~D399
	—	✓	✓	✓	✓	✓

Explanation

When the RST command is driven, motion of its specific device is as follows:

Device	Status
Y, M	Coil and contact will be set to “OFF”.
T, C	Present values of the timer or counter will be set to 0, and the coil and contact will be set to “OFF.”
D	The content value will be set to 0.

When the RST command is not driven, motion of its specific device is unchanged.

Example

Ladder diagram

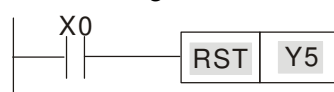

Command code: Operation:

LD	X0	Load contact A of X0
RST	Y5	Clear contact Y5

Mnemonic	Function	
TMR	16-bit timer	
Operand	T-K	T0~T159, K0~K32,767
	T-D	T0~T159, D0~D399

Explanation

When TMR command is executed, the specific coil of timer is ON and timer will start to count. When the setting value of timer is attained (counting value \geq setting value), the contact will be as following

NO(Normally Open) contact	Open collector
NC(Normally Closed) contact	Close collector

When the RST command is not driven, motion of its specific device remains unchanged.

Example

Ladder Diagram:

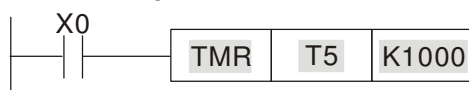

Command code:

Operation:

LD	X0	Load contact A of X0
TMR	T5 K1000	Setting of T5 counter is K1000.

Mnemonic	Function	
CNT	Clear contact or register	
Operand	C-K	C0~C79, K0~K32,767
	C-D	C0~C79, D0~D399

Explanation

When the CNT command is executed from OFF \rightarrow ON, which means that the counter coil is driven, and 1 should thus be added to the counter's value; when the counter achieved specific set value (value of counter = the setting value), motion of the contact is as follows:

NO(Normally Open) contact	Open collector
NC(Normally Close) contact	Close collector

If there is counting pulse input after counting is attained, the contacts and the counting values will be unchanged. To re-count or to conduct the CLEAR motion, please use the RST command.

Example

Ladder diagram:

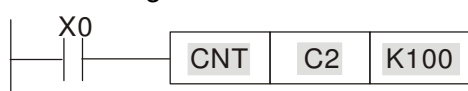

Command code:

Operation

LD	X0	Load contact A of
CNT	C2 K100	Setting of C2 counter is K100.

Mnemonic	Function	
MC/MCR	Master control Start/Reset	
Operand	N0~N7	

Explanation

1. MC is the main-control start command. When the MC command is executed, the execution of commands between MC and MCR will not be interrupted. When MC command is OFF, the motion of the commands that between MC and MCR is described as follows:

Command	Description
Timer	The counting value is set back to zero, the coil and the contact are both turned OFF
Accumulative timer	The coil is OFF, and the timer value and the contact stay at their present condition
Subroutine timer	The counting value is back to zero. Both coil and contact are turned OFF.
Counter	The coil is OFF, and the counting value and the contact stay at their present condition
Coils driven up by the OUT command	All turned OFF
Devices driven up by the SET and RST commands	Stay at present condition
Application commands	All of them are not acted , but the nest loop FOR-NEXT command will still be executed for times defined by users even though the MC-MCR commands is OFF.

2. MCR is the main-control ending command that is placed at the end of the main-control program and there should not be any contact commands prior to the MCR command.

3. Commands of the MC-MCR main-control program support the nest program structure, with 8 layers as its greatest. Please use the commands in order from N0~N7, and refer to the following:

Example

Ladder Diagram:

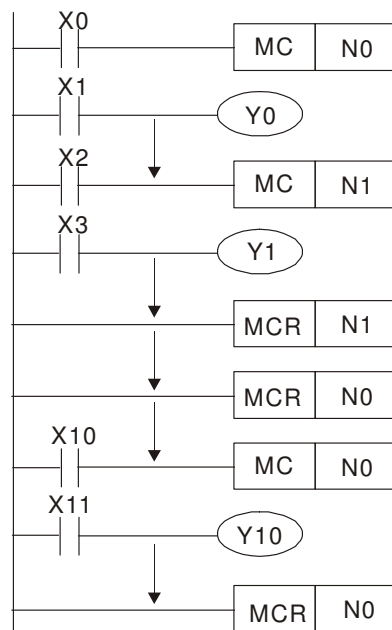

Command code: Operation:

LD	X0	Load A contact of X0
MC	N0	Enable N0 common series connection contact
LD	X1	Load A contact of X1
OUT	Y0	Drive Y0 coil
:		
LD	X2	Load A contact of X2
MC	N1	Enable N1 common series connection contact
LD	X3	Load A contact of X3
OUT	Y1	Drive Y1 coil
:		
MCR	N1	Disable N1 common series connection contact
:		
MCR	N0	Disable N0 common series connection contact

:	LD	X10	Load A contact of X10
	MC	NO	Enable NO common series connection contact
	LD	X11	Load A contact of X0
	OUT	Y10	Enable NO common series connection contact
:			Load A contact of X1
	MCR	NO	Drive Y0 coil

Mnemonic	Function					
LDP	Rising-edge detection operation					
Operand	X0~X17	Y0~Y17	M0~M799	T0~159	C0~C79	D0~D399
	✓	✓	✓	✓	✓	—

Explanation Usage of the LDP command is the same as the LD command, but the motion is different. It is used to reserve present contents and at the same time, saving the detection status of the acquired contact rising-edge into the accumulative register.

Example Ladder diagram:

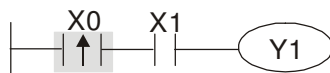

Command code: Operation:

LDP	X0	Start X0 rising-edge detection
AND	X1	Series connection A contact of X1
OUT	Y1	Drive Y1 coil

Remarks Please refer to the specification of each model series for the applicable range of operands.
If rising-edge status is ON when PLC power is off, then the rising-edge status will be TRUE when PLC power is on.

Mnemonic	Function					
LDF	Falling-edge detection operation					
Operand	X0~X17	Y0~Y17	M0~M799	T0~159	C0~C79	D0~D399
	✓	✓	✓	✓	✓	—

Explanation Usage of the LDF command is the same as the LD command, but the motion is different. It is used to reserve present contents and at the same time, saving the detection status of the acquired contact falling-edge into the accumulative register.

Example Ladder diagram:

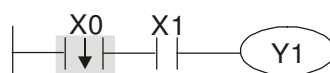

Command code: Operation:

LDF	X0	Start X0 falling-edge detection
AND	X1	Series connection A contact of X1
OUT	Y1	Drive Y1 coil

Mnemonic	Function					
ANDP	Rising-edge series connection					
Operand	X0~X17	Y0~Y17	M0~M799	T0~159	C0~C79	D0~D399
	✓	✓	✓	✓	✓	—

Explanation ANDP command is used in the series connection of the contacts' rising-edge detection.

Ladder diagram:

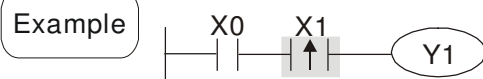

Command code:

Operation:

LD	X0	Load A contact of X0
ANDP	X1	X1 rising-edge detection in series connection
OUT	Y1	Drive Y1 coil

Mnemonic	Function					
ANDF	Falling-edge series connection					
Operand	X0~X17	Y0~Y17	M0~M799	T0~159	C0~C79	D0~D399
	✓	✓	✓	✓	✓	—

Explanation ANDF command is used in the series connection of the contacts' falling-edge detection.

Ladder diagram:

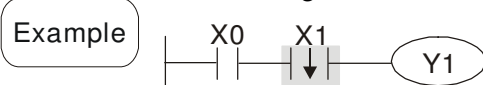

Command code:

Operation:

LD	X0	Load A contact of X0
ANDF	X1	X1 falling-edge detection in series connection
OUT	Y1	Drive Y1 coil

Mnemonic	Function					
ORP	Rising-edge parallel connection					
Operand	X0~X17	Y0~Y17	M0~M799	T0~159	C0~C79	D0~D399
	✓	✓	✓	✓	✓	—

The ORP commands are used in the parallel connection of the contact's rising-edge detection.

Explanation

Ladder diagram:

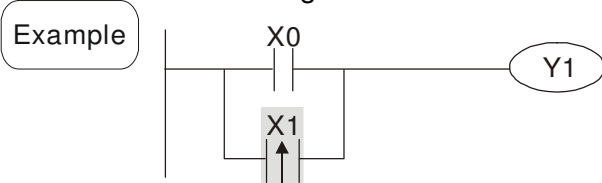

Command code:

Operation:

LD	X0	Load A contact of X0
ORP	X1	X1 rising-edge detection in parallel connection
OUT	Y1	Drive Y1 coil

Mnemonic	Function					
ORF	Falling-edge parallel connection					
Operand	X0~X17	Y0~Y17	M0~M799	T0~159	C0~C79	D0~D399
	✓	✓	✓	✓	✓	—

Explanation

The ORF commands are used in the parallel connection of the contact's falling-edge detection.

Example

Ladder diagram:

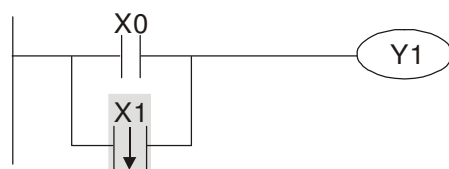

Command code: Operation:

LD	X0	Load A contact of X0
ORF	X1	X1 falling-edge detection in parallel connection
OUT	Y1	Drive Y1 coil

Mnemonic	Function					
PLS	Rising-edge output					
Operand	X0~X17	Y0~Y17	M0~M799	T0~159	C0~C79	D0~D399
	—	✓	✓	—	—	—

Explanation

When X0=OFF→ON (rising-edge trigger), PLS command will be executed and M0 will send the pulse of one time which the length is the time needed for one scan cycle.

Example

Ladder diagram:

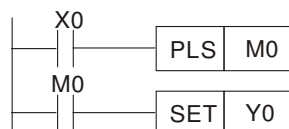

Timing diagram:

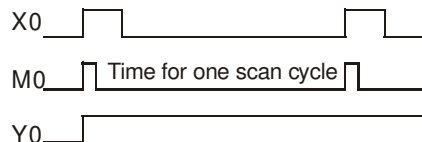

Command code: Operation:

LD	X0	Load A contact of X0
PLS	M0	M0 rising-edge output
LD	M0	Load the contact A of M0
SET	Y0	Y0 latched (ON)

Mnemonic	Function					
PLF	Falling-edge output					
Operand	X0~X17	Y0~Y17	M0~M799	T0~159	C0~C79	D0~D399
	—	✓	✓	—	—	—

Explanation

When X0= ON→OFF (falling-edge trigger), PLF command will be executed and M0 will send the pulse of one time which the length is the time for scan one time.

Example

Ladder diagram:

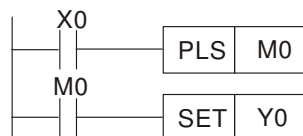

Timing Diagram:

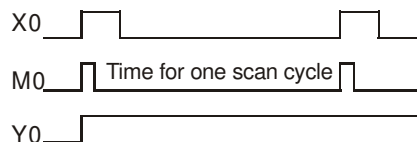

Command code: Operation:

LD	X0	Load contact A of X0
PLF	M0	M0 falling-edge output
LD	M0	Load contact A of M0
SET	Y0	Y0 latched (ON)

Mnemonic	Function
END	Program End
Operand	None

Explanation

It needs to add the END command at the end of ladder diagram program or command program. PLC will scan from address 0 to END command, after the execution it will return to address 0 and scan again.

Mnemonic	Function
NOP	No action
Operand	None

Explanation

NOP command does no operation in the program; the result of executing this command will remain the logic operation. Use NOP command if user wants to delete certain command without changing the length of the program.

Example

Ladder diagram:

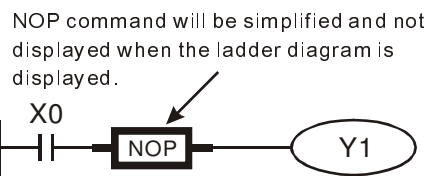

Command code: Operation:

LD	X0	Load contact B of X0
NOP		No function
OUT	Y1	Drive Y1 coil

Mnemonic	Function
INV	Inverse operation result
Operand	None

Explanation

The operation result (before executing INV command) will be saved inversely into cumulative register.

Example

Ladder diagram:



Command code: Operation:

LD	X0	Load contact A of X0
INV		Operation result inverted
OUT	Y1	Drive Y1 coil

Mnemonic	Function
P	Indicator
Operand	P0~P255

Explanation

Indicator P allows API 00 CJ command and API 01 CALL command to skip from 0. Though it is not necessary to start from number 0, same number can not be used twice or serious error would occur.

Example

Ladder diagram:

Command code: Operation:

LD	X0	Load contact A of X0
CJ	P10	Skip command CJ to P10
:		

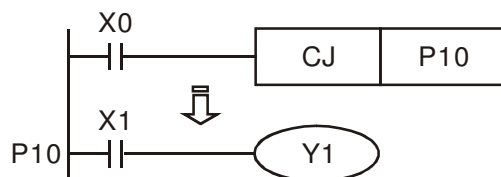

P10	Indicator P10
------------	---------------

LD	X1	Load contact A of X1
----	----	----------------------

OUT	Y1	Drive Y1 coil
-----	----	---------------

14-6-3 Description of the Application Commands

	API	Mnemonic Codes		P Command	Function	STEPS	
		16-bit	32-bit			16bit	32bit
Loop control	01	CALL	-	✓	CALL subroutine	3	-
	06	FEND	-	-	The end of main program	1	-
Transmission Comparison	10	CMP	-	✓	Compare	7	13
	11	ZCP	-	✓	Zone compare	9	17
	12	MOV	-	✓	Data Move	5	9
	15	BMOV	-	✓	Block move	7	-
Four Fundamental Operations of Arithmetic	20	ADD	-	✓	Perform the addition of BIN data	7	13
	21	SUB	-	✓	Perform the subtraction of BIN data	7	13
	22	MUL	-	✓	Perform the multiplication of BIN data	7	13
	23	DIV	-	✓	Perform the division of BIN data	7	13
	24	INC	-	✓	Perform the addition of 1	3	5
	25	DEC	-	✓	Perform the subtraction of 1	3	5
Rotation and Displacement	30	ROR	-	✓	Rotate to the right	5	-
	31	ROL	-	✓	Rotate to the left	5	-
Data Processing	40	ZRST	-	✓	Zero Reset	5	-
Contact type logic operation	215	LD&	DLD&	-	Contact Logical Operation LD#	5	9
	216	LD	DLD	-	Contact type logic operation LD #	5	9
	217	LD^	DLD^	-	Contact Logical Operation LD#	5	9
	218	AND&	DAND&	-	Contact Logical Operation AND#	5	9
	219	ANDI	DANDI	-	Contact Logical Operation AND#	5	9
	220	AND^	DAND^	-	Contact Logical Operation AND#	5	9
	221	OR&	DOR&	-	Contact Logical Operation OR #	5	9
	222	OR	DOR	-	Contact Logical Operation OR #	5	9
	223	OR^	DOR^	-	Contact Logical Operation OR #	5	9
Contact Type	224	LD=	DLD=	-	Load Compare LD※	5	9
	225	LD>	DLD>	-	Load Compare LD※	5	9

	API	Mnemonic Codes		P Command	Function	STEPS	
		16-bit	32-bit			16bit	32bit
Comparison	226	LD<	DLD<	-	Load Compare LD※	5	9
	228	LD<>	DLD<>	-	Load Compare LD※	5	9
	229	LD<=	DLD<=	-	Load Compare LD※	5	9
	230	LD>=	DLD>=	-	Load Compare LD※	5	9
	232	AND=	DAND=	-	AND Compare※	5	9
	233	AND>	DAND>	-	AND Compare※	5	9
	234	AND<	DAND<	-	AND Compare※	5	9
	236	AND<>	DAND< >	-	AND Compare※	5	9
	237	AND<=	DAND< =	-	AND Compare※	5	9
	238	AND>=	DAND> =	-	AND Compare※	5	9
	240	OR=	DOR=	-	OR compare ※	5	9
	241	OR>	DOR>	-	OR compare ※	5	9
	242	OR<	DOR<	-	OR compare ※	5	9
	244	OR<>	DOR<>	-	OR compare ※	5	9
	245	OR<=	DOR<=	-	OR compare ※	5	9
246	OR>=	DOR>=	-	OR compare ※	5	9	
Special command for AC motor drive	139	RPR	-	✓	Read the parameters	5	-
	140	WPR	-	✓	Write the parameters	5	-
	141	FPID	-	✓	Drive PID control	9	-
	142	FREQ	-	✓	Control the drive frequency	7	-
	261	CANRX	-	✓	Read CANopen Slave data	9	-
	263	TORQ	-	✓	Set target torque	5	-
	264	CANTX	-	✓	Write CANopen Slave data	9	-
	265	CANFLS	-	✓	Update the mapping special D of CANopen	3	-

14-6-4 Explanation for the Application Commands

API		CALL		(S)	Call Subroutine
01			P		

Bit Devices			Word Devices								16-bit command (3 STEPS)	
X	Y	M	K	H	KnX	KnY	KnM	T	C	D	CALL	CALLP
Operands:											32-bit command	
S: Operand S can designate P.											— — — —	
Operand S of C2000 series can designate P0~P63.											Flag signal: None	

Explanation

1. **S**: The pointer of call subroutine.
2. Edit the subroutine designated by the pointer after FEND instruction.
3. If only CALL instruction is in use, it can call subroutines of the same pointer number with no limit of times.
4. Subroutine can be nested for 5 levels including the initial CALL instruction. (If entering the sixth level, the subroutine won't be executed.)

API		ZRST		(D1) (D2)	Zero Reset
40			P		

	Bit Devices			Word Devices								16-bit command (5 STEPS)	
	X	Y	M	K	H	KnX	KnY	KnM	T	C	D		
D ₁		*	*						*	*	*	ZRST	ZRSTP
D ₂		*	*						*	*	*	32-bit command	
Operands:												-	
No of D ₁ operand. ≤ No. of D ₂ operand												-	
D ₁ and D ₂ must select same device type												-	
Please refer to the specification of each model series for applicable range of the device.												Flag signal: none	

Explanation

D₁: Start device of the range to be reset **D₂**: End device of the range to be reset

When **D₁** > **D₂**, only operands designated by **D₂** will be reset.

Example

1. When X0 = On, auxiliary relays M300 ~ M399 will be reset to Off.
2. When X1 = On, 16 counters C0 ~ C127 will all be reset (writing in 0; contact and coil being reset to Off).
3. When X10 = On, timers T0 ~ T127 will all be reset (writing in 0; contact and coil being reset to Off).
4. When X3 = On, data registers D0 ~ D100 will be reset to 0.

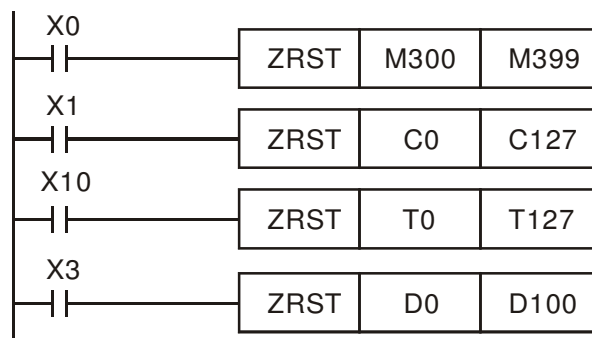

Remarks

1. Devices, e.g. bit devices Y, M, S and Word Devices T, C, D, can use RST instruction.
2. API 16 FMOV instruction is also to send K0 to Word Devices T, C, D or bit registers KnY, KnM, KnS for reset.

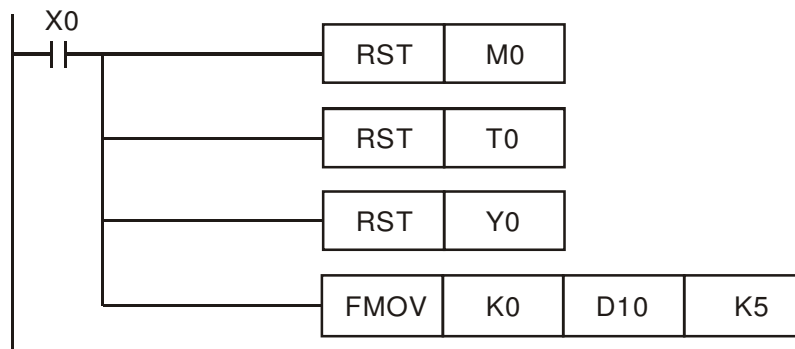

API											
215~ 217	D	LD#		(S1)	(S2)						Contact Logical Operation LD#

	Bit Devices			Word Devices								16-bit command (5 STEPS)	
	X	Y	M	K	H	KnX	KnY	KnM	T	C	D	LD#	ZRSTP
S₁				*	*	*	*	*	*	*	*		
S₂				*	*	*	*	*	*	*	*		
Operands: #: &, , ^												32-bit command (9 STEPS)	
Please refer to the specifications of each model for the range of operands.												DLD# - - -	
												Flag signal: none	

- Explanation**
- S₁**: Data source device 1 **S₂**: Data source device 2
 - This instruction compares the content in **S₁** and **S₂**. If the result is not "0", the continuity of the instruction is enabled. If the result is "0", the continuity of the instruction is disabled.
 - LD# (**#**: &, |, ^) instruction is used for direct connection with BUS.

API No.	16-bit instruction	32-bit instruction	Continuity condition	No-continuity condition
215	LD&	DLD&	S₁ & S₂ ≠ 0	S₁ & S₂ = 0
216	LD	DLD	S₁ S₂ ≠ 0	S₁ S₂ = 0
217	LD^	DLD^	S₁ ^ S₂ ≠ 0	S₁ ^ S₂ = 0

- &**: Logical "AND" operation
- |**: Logical "OR" operation
- ^**: Logical "XOR" operation

- Example**
- When the result of logical AND operation of C0 and C10 ≠ 0, Y10 = On.
 - When the result of logical OR operation of D200 and D300 ≠ 0 and X1 = On, Y11 = On will be retained.

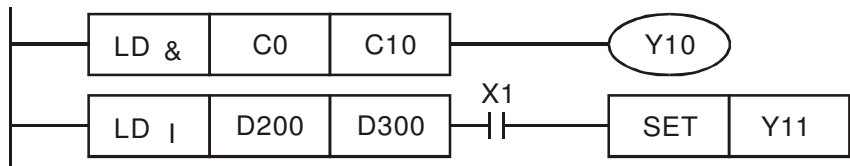

API											
218~ 220	D	AND#		(S1)	(S2)						Contact Logical Operation AND#

	Bit Devices			Word Devices							16-bit command (5 STEPS)		
	X	Y	M	K	H	KnX	KnY	KnM	T	C	D	AND#	ZRSTP
S₁				*	*	*	*	*	*	*	*		
S₂				*	*	*	*	*	*	*	*		
Operands: #: &, , ^												32-bit command (9 STEPS)	
Please refer to the specifications of each model for the range of operands.												DAND# - - -	
												Flag signal: none	

Explanation

1. **S₁**: Data source device 1 **S₂**: Data source device 2
2. This instruction compares the content in **S₁** and **S₂**. If the result is not “0”, the continuity of the instruction is enabled. If the result is “0”, the continuity of the instruction is disabled.
3. **AND#** (#: &, |, ^) is an operation instruction used on series contacts.

API No.	16-bit instruction	32-bit instruction	Continuity condition	No-continuity condition
218	AND&	DAND&	S₁ & S₂ ≠ 0	S₁ & S₂ = 0
219	AND	DAND	S₁ S₂ ≠ 0	S₁ S₂ = 0
220	AND^	DAND^	S₁ ^ S₂ ≠ 0	S₁ ^ S₂ = 0

4. **&**: Logical “AND” operation
5. **|**: Logical “OR” operation
6. **^**: Logical “XOR” operation

Example

1. When X0 = On and the result of logical AND operation of C0 and C10 ≠ 0, Y10 = On.
2. When X1 = Off and the result of logical OR operation of D10 and D0 ≠ 0 and X1 = On, Y11 = On will be retained.
3. When X2 = On and the result of logical XOR operation of 32-bit register D200 (D201) and 32-bit register D100 (D101) ≠ 0 or M3 = On, M50 = On.

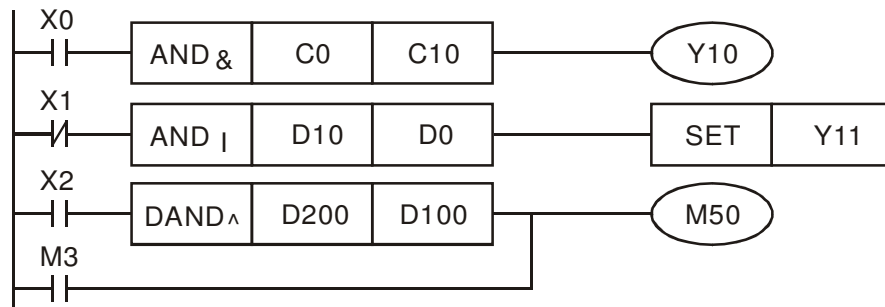

API											
221~ 223	D	OR#		(S1)	(S2)						Contact Logical operation OR#

	Bit Devices			Word Devices								16-bit command (5 STEPS)		
	X	Y	M	K	H	KnX	KnY	KnM	T	C	D	OR#		ZRSTP
S₁				*	*	*	*	*	*	*	*	32-bit command (9 STEPS)		
S₂				*	*	*	*	*	*	*	*	DOR# - - -		
Operand: #: &, , ^												Flag signal: none		
Please refer to the specifications of each model for the range of operands.														

Explanation

- S₁**: Data source device 1 **S₂**: Data source device 2
- This instruction compares the content in **S₁** and **S₂**. If the result is not "0", the continuity of the instruction is enabled. If the result is "0", the continuity of the instruction is disabled.
- OR# (#: &, |, ^) is an operation instruction used on parallel contacts.

API No.	16-bit instruction	32-bit instruction	Continuity condition	No-continuity condition
221	OR&	DOR&	S₁ & S₂ ≠ 0	S₁ & S₂ = 0
222	OR	DOR	S₁ S₂ ≠ 0	S₁ S₂ = 0
223	OR^	DOR^	S₁ ^ S₂ ≠ 0	S₁ ^ S₂ = 0

- &**: Logical "AND" operation
- |**: Logical "OR" operation
- ^**: Logical "XOR" operation

Example

When X1 = On and the result of logical AND operation of C0 and C10 ≠ 0, Y10 = On.

- M60 will be On, if X2 and M30 are On with one of the following two conditions: 1. The OR operation result of 32-bit register D10 (D11) and 32-bit register D20(D21) does not equal to 0. 2. The XOR operation result of 32-bit counter C235 and 32bits register D200 (D201) does not equal 0.

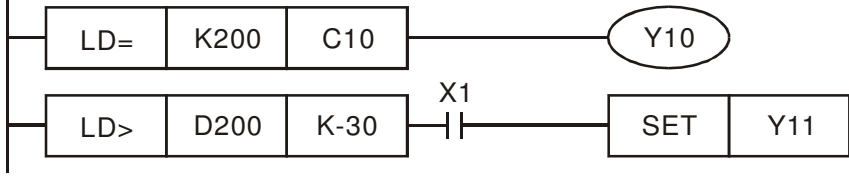

API											
224~230	D	LD※			(S1)	(S2)					Load Compare※

	Bit Devices			Word Devices							16-bit command (5 STEPS)		
	X	Y	M	K	H	KnX	KnY	KnM	T	C	D	LD※	ZRSTP
S₁				*	*	*	*	*	*	*	*		
S₂				*	*	*	*	*	*	*	*		
Operands: ※: =, >, <, <>, ≤, ≥												32 bit bits command (9 STEPS)	
Please refer to the specifications of each model for the range of operands.												DLD※ - - -	
												Flag signal: none	

Explanation

1. **S₁**: Data source device 1 **S₂**: Data source device 2
2. This instruction compares the content in **S₁** and **S₂**. Take API224 (LD=) for example, if the result is “=”, the continuity of the instruction is enabled. If the result is “≠”, the continuity of the instruction is disabled.
3. LD※ (※: =, >, <, <>, ≤, ≥) instruction is used for direct connection with BUS.

API No.	16-bit instruction	32-bit instruction	Continuity condition	No-continuity condition
224	LD=	DLD=	S₁ = S₂	S₁ ≠ S₂
225	LD>	DLD>	S₁ > S₂	S₁ ≤ S₂
226	LD<	DLD<	S₁ < S₂	S₁ ≥ S₂
228	LD<>	DLD<>	S₁ ≠ S₂	S₁ = S₂
229	LD≤	DLD≤	S₁ ≤ S₂	S₁ > S₂
230	LD≥	DLD≥	S₁ ≥ S₂	S₁ < S₂

Example

1. When the content in C10 = K200, Y10 = On.
2. When the content in D200 > K-30 and X1 = On, Y11= On will be retained.

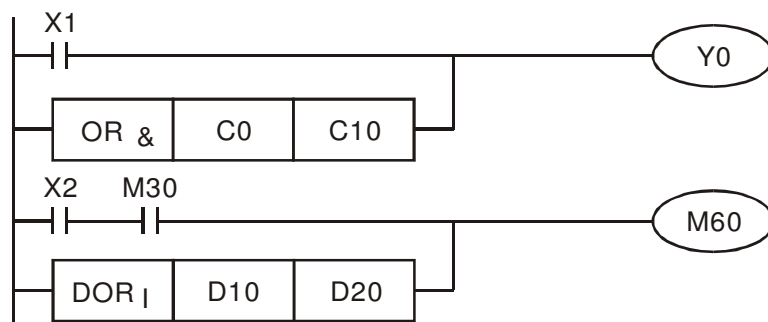

API											
232~ 238	D	AND※		(S1)	(S2)						AND Compare※

Bit Devices			Word Devices								16-bit command (5 STEPS)				
	X	Y	M	K	H	KnX	KnY	KnM	T	C	D	AND※	ZRSTP		
S ₁				*	*	*	*	*	*	*	*				
S ₂				*	*	*	*	*	*	*	*				
Operands: ※: =, >, <, <>, ≤, ≥												32-bit command (9 STEPS)			
Please refer to the specifications of each model for the range of operands.												DAND※		— — —	
												Flag signal: none			

- Explanation**
1. **S₁**: Data source device 1 **S₂**: Data source device 2
 2. This instruction compares the content in **S₁** and **S₂**. Take API232 (AND=) for example, if the result is "=", the continuity of the instruction is enabled. If the result is "≠", the continuity of the instruction is disabled.
 3. AND※ (※: =, >, <, <>, ≤, ≥) is a comparison instruction is used on series contacts

API No.	16-bit instruction	32-bit instruction	Continuity condition	No-continuity condition
232	AND=	DAND=	S ₁ = S ₂	S ₁ ≠ S ₂
233	AND>	DAND>	S ₁ > S ₂	S ₁ ≤ S ₂
234	AND<	DAND<	S ₁ < S ₂	S ₁ ≥ S ₂
236	AND<>	DAND<>	S ₁ ≠ S ₂	S ₁ = S ₂
237	AND≤	DAND≤	S ₁ ≤ S ₂	S ₁ > S ₂
238	AND≥	DAND≥	S ₁ ≥ S ₂	S ₁ < S ₂

- Example**
1. When X0 = On and the content in C10 = K200, Y10 = On.
 2. When X1 = Off and the content in D0 ≠ K-10, Y11 = On will be retained.
 3. When X2 = On and the content in 32-bit register D0 (D11) < 678,493 or M3 = On, M50 = On.

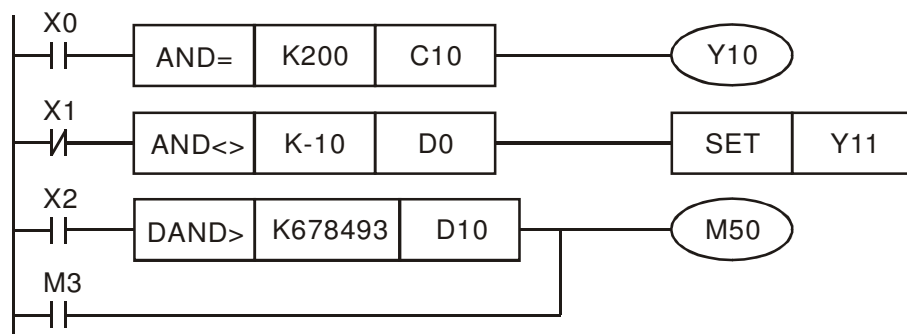

API	CANRX	P	(S1)	(S2)	(S3)	(D)	Read CANopen slave data
261							

	Bit Devices			Word Devices							16-bit command (7 STEPS)		
	X	Y	M	K	H	KnX	KnY	KnM	T	C	D	FREQ	FREQP
S ₁				*	*								
S ₂				*	*								
S ₃				*	*								
D									*	*	*		

Operand: none

Flag signal: M1028

Explanation

1. **S₁**: Slave station number, **S₂**: main index, **S₃**: sub-index + bit length, **D**: save address
2. Command CANRX can read the corresponding slave. Index. When executing this command, it will send SDO message to the slave. At this time, M1066 and M1067 are 0 but when reading is complete M1066 will set to 1. If the slave replied an accurate response, the value will be written to the designated register and M1067 is now set to 1. However, if the slave replied an inaccurate response, this error message will be recorded in D1076~D1079.

Example

M1002: touch once to activate PLC and change K4M400=K1. After the change, different message will be displayed when M1066 is set to 1.

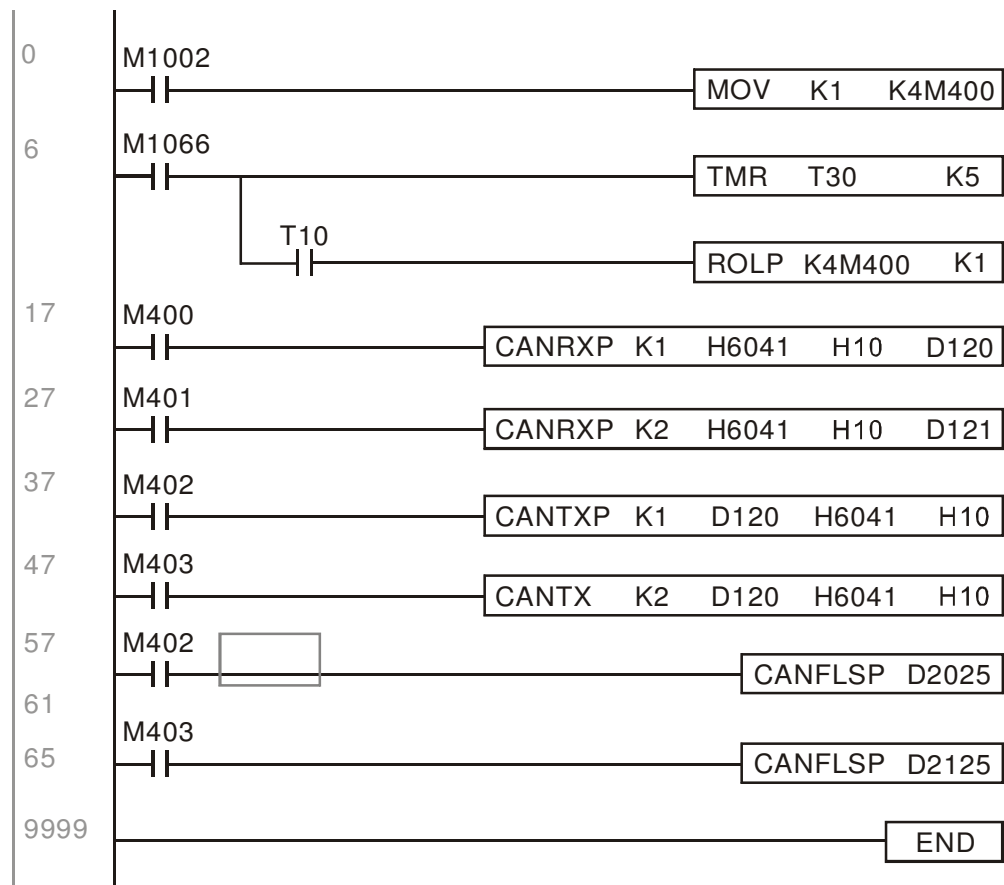

14-7 Error and Troubleshoot

Fault	ID	Fault Descript	Corrective Action
PLod	50	Data write error	Check if there is error in the program and download the program again.
PLSv	51	Data write error when executing	Re-apply the power and download the program again.
PLdA	52	Program upload error	Upload again. If error occurs continuously, please return to the factory.
PLFn	53	Command error when download program	Check if there is error in the program and download the program again.
PLor	54	Program capacity exceeds memory capacity	Re-apply the power and download the program again.
PLFF	55	Command error when executing	Check if there is error in the program and download the program again.
PLSn	56	Check sum error	Check if there is error in the program and download the program again.
PLEd	57	There is no "END" command in the program	Check if there is error in the program and download the program again.
PLCr	58	The command MC is continuous used more than 9 times	Check if there is error in the program and download the program again.
PLdF	59	Download program error	Check if there is error in the program and download the program again.
PLSF	60	PLC scan time over-time	Check if the program code is inaccurately written and download the program again.

Chapter 15 Suggestions and Error Corrections for Standard AC Motor Drives

- 15-1 Maintenance and Inspections
- 15-2 Greasy Dirt Problem
- 15-3 Fiber Dust Problem
- 15-4 Erosion Problem
- 15-5 Industrial Dust Problem
- 15-6 Wiring and Installation Problem
- 15-7 Multi-function Input/Output Terminals Problem

The AC motor drive has a comprehensive fault diagnostic system that includes several different alarms and fault messages. Once a fault is detected, the corresponding protective functions will be activated. The following faults are displayed as shown on the AC motor drive digital keypad display. The six most recent faults can be read from the digital keypad or communication.

The AC motor drive is made up by numerous components, such as electronic components, including IC, resistor, capacity, transistor, and cooling fan, relay, etc. These components can't be used permanently. They have limited-life even under normal operation. Preventive maintenance is required to operate this AC motor drive in its optimal condition, and to ensure a long life.

Check your AC motor drive regularly to ensure there are no abnormalities during operation and follows the precautions:



- ☑ Wait 5 seconds after a fault has been cleared before performing reset via keypad of input terminal.
- ☑ When the power is off after 5 minutes for $\leq 22\text{kW}$ models and 10 minutes for $\geq 30\text{kW}$ models, please confirm that the capacitors have fully discharged by measuring the voltage between + and -. The voltage between + and - should be less than 25VDC.
- ☑ Only qualified personnel can install, wire and maintain drives. Please take off any metal objects, such as watches and rings, before operation. And only insulated tools are allowed.
- ☑ Never reassemble internal components or wiring.
- ☑ Make sure that installation environment comply with regulations without abnormal noise, vibration and smell.

15-1 Maintenance and Inspections

Before the check-up, always turn off the AC input power and remove the cover. Wait at least 10 minutes after all display lamps have gone out, and then confirm that the capacitors have fully discharged by measuring the voltage between DC+ and DC-. The voltage between DC+ and DC- should be less than 25VDC.

Ambient environment

Check Items	Methods and Criterion	Maintenance Period		
		Daily	Half Year	One Year
Check the ambient temperature, humidity, vibration and see if there are any dust, gas, oil or water drops	Visual inspection and measurement with equipment with standard specification	<input type="radio"/>		
If there are any dangerous objects	Visual inspection	<input type="radio"/>		

Voltage

Check Items	Methods and Criterion	Maintenance Period		
		Daily	Half Year	One Year
Check if the voltage of main circuit and control circuit is correct	Measure with multimeter with standard specification	<input type="radio"/>		

Digital Keypad Display

Check Items	Methods and Criterion	Maintenance Period		
		Daily	Half Year	One Year
Is the display clear for reading	Visual inspection	<input type="radio"/>		
Any missing characters	Visual inspection	<input type="radio"/>		

Mechanical parts

Check Items	Methods and Criterion	Maintenance Period		
		Daily	Half Year	One Year
If there is any abnormal sound or vibration	Visual and aural inspection		<input type="radio"/>	
If there are any loose screws	Tighten the screws		<input type="radio"/>	
If any part is deformed or damaged	Visual inspection		<input type="radio"/>	
If there is any color change by overheating	Visual inspection		<input type="radio"/>	
If there is any dust or dirt	Visual inspection		<input type="radio"/>	

Main circuit

Check Items	Methods and Criterion	Maintenance Period		
		Daily	Half Year	One Year
If there are any loose or missing screws	Tighten or replace the screw	<input type="radio"/>		
If machine or insulator is deformed, cracked, damaged or with color change due to overheating or ageing	Visual inspection NOTE: Please ignore the color change of copper plate		<input type="radio"/>	
If there is any dust or dirt	Visual inspection		<input type="radio"/>	

Terminals and wiring of main circuit

Check Items	Methods and Criterion	Maintenance Period		
		Daily	Half Year	One Year
If the terminal or the plate is color change or deformation due to overheat	Visual inspection		<input type="radio"/>	
If the insulator of wiring is damaged or color change	Visual inspection		<input type="radio"/>	
If there is any damage	Visual inspection	<input type="radio"/>		

DC capacity of main circuit

Check Items	Methods and Criterion	Maintenance Period		
		Daily	Half Year	One Year
If there is any leak of liquid, color change, crack or deformation	Visual inspection	<input type="radio"/>		
If the safety valve is not removed? If valve is inflated?	Visual inspection	<input type="radio"/>		
Measure static capacity when required		<input type="radio"/>		

Resistor of main circuit

Check Items	Methods and Criterion	Maintenance Period		
		Daily	Half Year	One Year
If there is any peculiar smell or insulator cracks due to overheat	Visual inspection, smell	<input type="radio"/>		
If there is any disconnection	Visual inspection	<input type="radio"/>		
If connection is damaged?	Measure with multimeter with standard specification	<input type="radio"/>		

Transformer and reactor of main circuit

Check Items	Methods and Criterion	Maintenance Period		
		Daily	Half Year	One Year
If there is any abnormal vibration or peculiar smell	Visual, aural inspection and smell	○		

Magnetic contactor and relay of main circuit

Check Items	Methods and Criterion	Maintenance Period		
		Daily	Half Year	One Year
If there are any loose screws	Visual and aural inspection	○		
If the contact works correctly	Visual inspection	○		

Printed circuit board and connector of main circuit

Check Items	Methods and Criterion	Maintenance Period		
		Daily	Half Year	One Year
If there are any loose screws and connectors	Tighten the screws and press the connectors firmly in place.		○	
If there is any peculiar smell and color change	Visual and smell inspection		○	
If there is any crack, damage, deformation or corrosion	Visual inspection		○	
If there is any liquid is leaked or deformation in capacity	Visual inspection		○	

Cooling fan of cooling system

Check Items	Methods and Criterion	Maintenance Period		
		Daily	Half Year	One Year
If there is any abnormal sound or vibration	Visual, aural inspection and turn the fan with hand (turn off the power before operation) to see if it rotates smoothly		○	
If there is any loose screw	Tighten the screw		○	
If there is any color change due to overheat	Change fan		○	

Ventilation channel of cooling system

Check Items	Methods and Criterion	Maintenance Period		
		Daily	Half Year	One Year
If there is any obstruction in the heat sink, air intake or air outlet	Visual inspection		○	

 **NOTE**

Please use the neutral cloth for clean and use dust cleaner to remove dust when necessary.

15-2 Greasy Dirt Problem

Serious greasy dirt problems generally occur in processing industries such as machine tools, punching machines and so on. Please be aware of the possible damages that greasy oil may cause to your drive:

1. Electronic components that silt up with greasy oil may cause the drive to burn out or even explode.
2. Most greasy dirt contains corrosive substances that may damage the drive.

Solution:

Install the AC motor drive in a standard cabinet to keep it away from dirt. Clean and remove greasy dirt regularly to prevent damage of the drive.

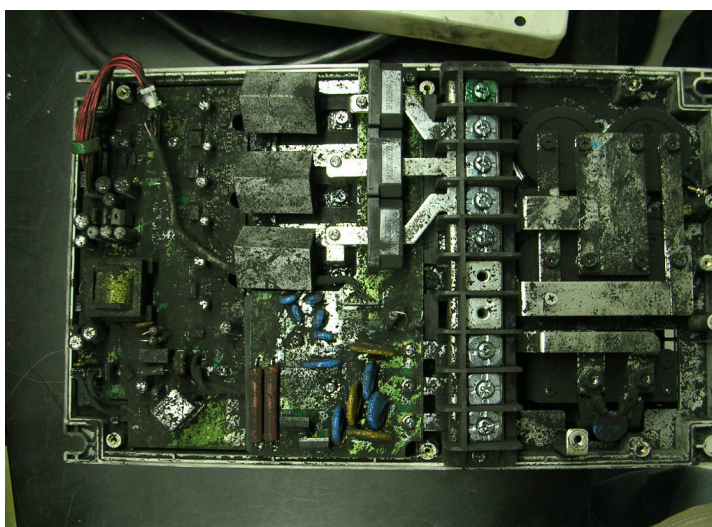

15-3 Fiber Dust Problem

Serious fiber dust problems generally occur in the textile industry. Please be aware of the possible damages that fiber may cause to your drives:

1. Fiber that accumulates or adheres to the fans will lead to poor ventilation and cause overheating problems.
2. Plant environments in the textile industry have higher degrees of humidity that may cause the drive to burn out, become damaged or explode due to wet fiber dust adhering to the devices.

Solution:

Install the AC motor drive in a standard cabinet to keep it away from fiber dust. Clean and remove fiber dust regularly to prevent damage to the drive.



15-4 Erosion Problem

Erosion problems may occur if any fluids flow into the drives. Please be aware of the damages that erosion may cause to your drive.

1. Erosion of internal components may cause the drive to malfunction and possibility to explode.

Solution:

Install the AC motor drive in a standard cabinet to keep it away from fluids. Clean the drive regularly to prevent erosion.

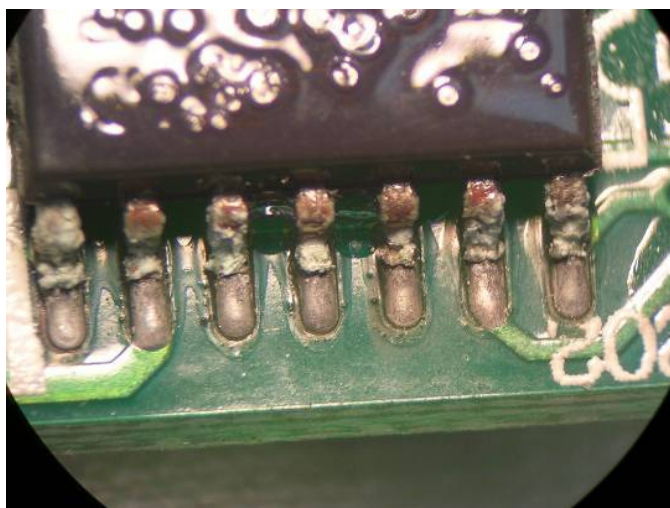
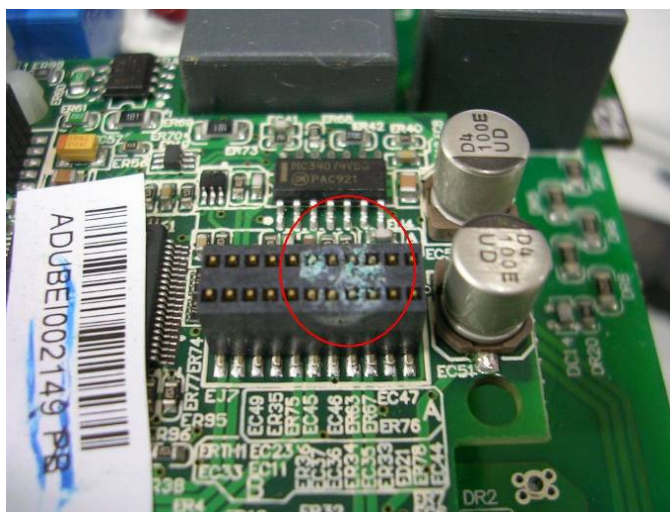
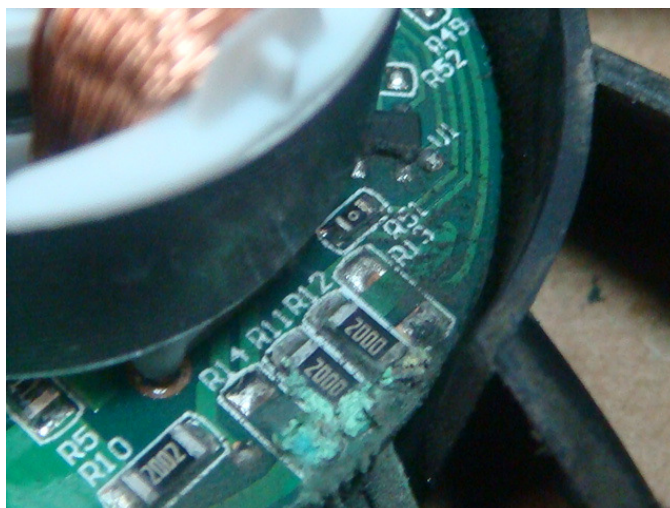

15-5 Industrial Dust Problem

Serious industrial dust pollution frequently occurs in stone processing plants, flour mills, cement plants, and so on. Please be aware of the possible damage that industrial dust may cause to your drives:

1. Dust accumulating on electronic components may cause overheating problem and shorten the service life of the drive.
2. Conductive dust may damage the circuit board and may even cause the drive to explode.

Solution:

Install the AC motor drive in a standard cabinet and cover the drive with a dust cover. Clean the cabinet and ventilation hole regularly for good ventilation.

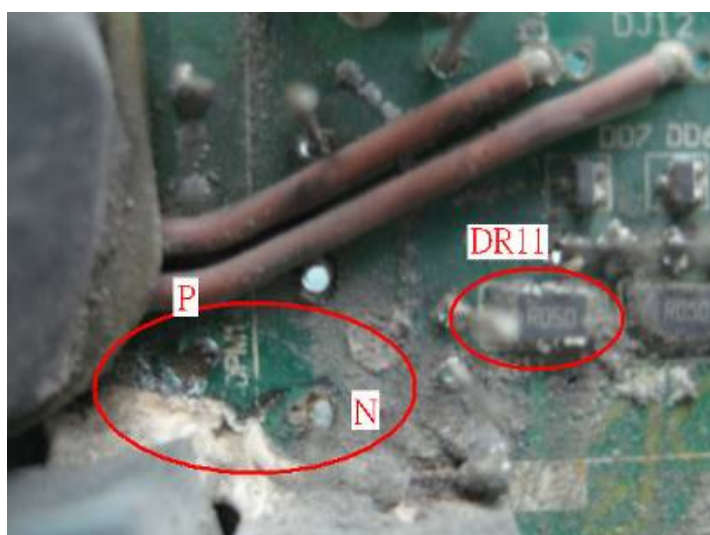
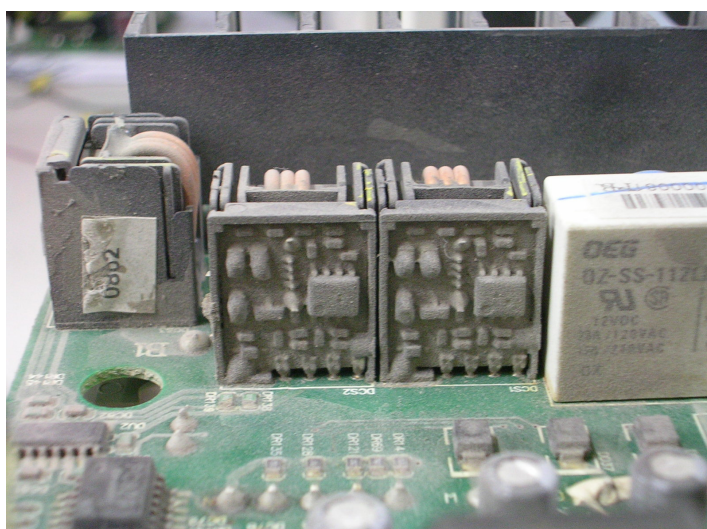

15-6 Wiring and Installation Problem

When wiring the drive, the most common problem is wrong wire installation or poor wiring. Please be aware of the possible damages that poor wiring may cause to your drives:

1. Screws are not fully fastened. Occurrence of sparks as impedance increases.
2. If a customer has opened the drive and modified the internal circuit board, the internal components may have been damaged.

Solution:

Ensure all screws are fastened when installing the AC motor drive. If the AC motor drive functions abnormally, send it back to the repair station. DO NOT try to reassemble the internal components or wire.

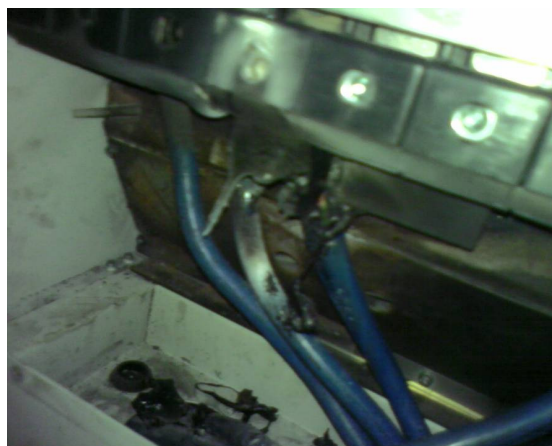
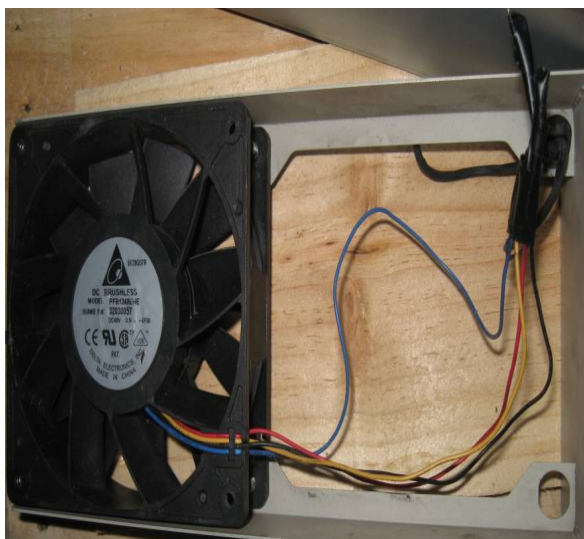
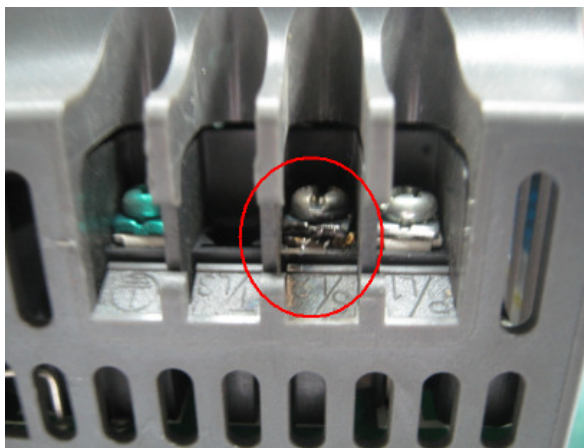

15-7 Multi-function Input/Output Terminals Problem

Multi-function input/output terminal errors are generally caused by over usage of terminals and not following specifications. Please be aware of the possible damages that errors on multi-function input/output terminals may cause to your drives:

1. Input/output circuit may burn out when the terminal usage exceeds its limit.

Solution:

Refer to the user manual for multi-function input output terminals usage and follow the specified voltage and current. DO NOT exceed the specification limits.

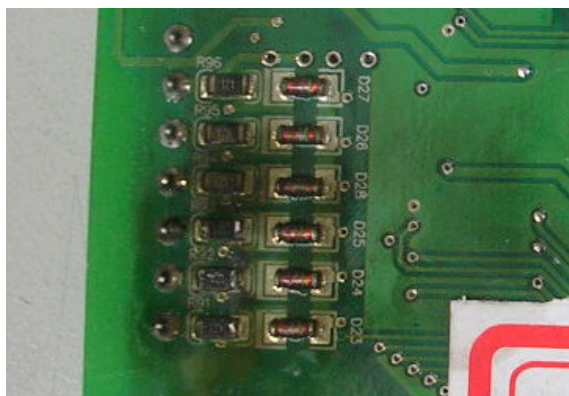
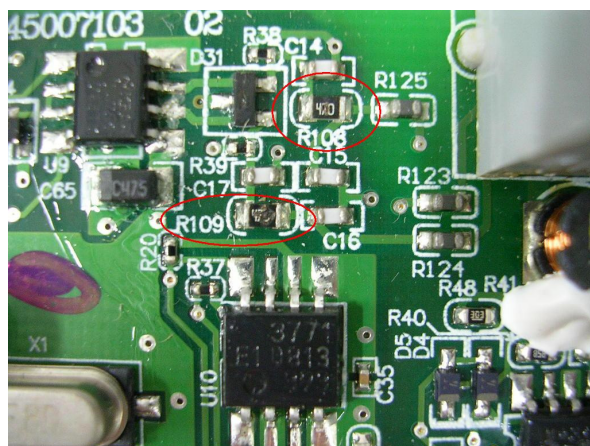
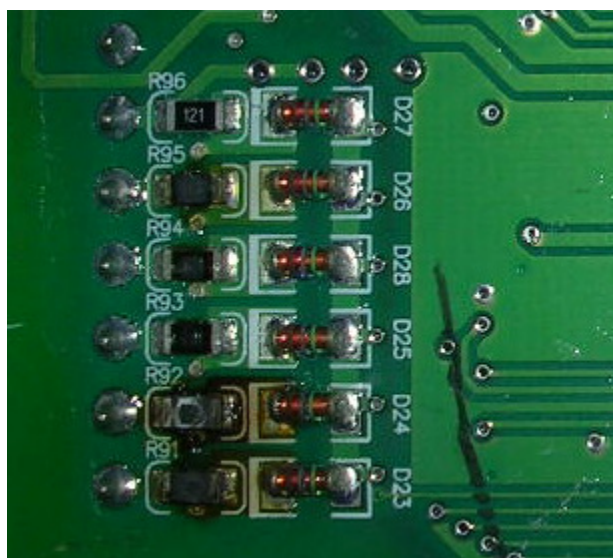

Appendix A. Publication History

V1.04→V1.05	
Explanations	Affected
New	
Add model name, appearance, size of the fan enlarged models	Chapter 1—Introduction
Add air flow rate for cooling and power dissipation of AC motor drive of the fan enlarged models	Chapter 2—Installation
Add the main circuit terminal specification of the fan enlarged models	Chapter 4—Main Circuit Terminals
Add the recommended non-fuse breaker current of the fan enlarged models	Chapter 6—Optional Accessories
Add the specification of fuse for the fan enlarged models	Chapter 6—Optional Accessories
Add the fan models, appearance and assembly of the fan enlarged models	Chapter 6—Optional Accessories
Add the specification of the fan enlarged models	Chapter 7—Specification
Add the setting of MO parameter (MO=67)	Parameter Group 02 (02-13~02-17)
Add the analog signal level achieved function	Parameter Group 03 (03-44~03-46)
Add PLC buffer	Parameter Group 04 (04-50~04-69)
Add the parameter named speed tracking on frequency derivative	Parameter Group 07 (07-38)
Add the parameter which is related to low ppr encoder	Parameter Group 10 (10-47~10-48)
Add the application of swing function of PLC	Chapter 10—Description of Parameter Setting (10-2 Adjustment & Application)
Revised	
Make an additional description of high speed mode parameter	Parameter Group 00 (00-14)
Correct the explanation of No.63 oSL	Chapter 12—Fault Codes and Descriptions
Correct the data of AC/DC reactor	Chapter 6—Optional Accessories
Correct the EMI filter models and their corresponding zero-phase reactors, the length of cable	Chapter 6—Optional Accessories
Correct the factory setting of heat sink over-heat warning	Parameter Group 06 (06-15)
Correct the setting of time for fault record	Parameter Group 06 (06-63~06-70)
Correct the factory setting of COM1 transmission speed	Parameter Group 09 (09-01)
Correct the factory setting of COM1 communication protocol	Parameter Group 09 (09-04)