



Automation for a Changing World

Delta Machine Vision System DMV2000 Series

Speed, Precision Smart Visual Inspection

The latest Delta Machine Vision System DMV2000 Series provides a smart and user friendly operation interface of high-speed, high-precision, and multi-processing ability. It supports multi I/O input and output, standard industrial network interfaces (Ethernet, RS-232, RS-485) and various machine vision inspection functions.

With the help of vision inspection tools in the DMV Series, the product quality and efficiency of the automated production line are substantially enhanced. The DMV Series can be effectively used in areas such as: general industrial machinery, automotive, rubber and plastics, pharmaceuticals, food, printing, packaging, metal processing, robotic arm integrated applications, TFT, semiconductors, solar energy and other related electronics industries, to achieve customer satisfaction with high quality products.

- ❑ Multiple cameras work synchronously for multi-tasking to enhance efficiency and save development costs
- ❑ Image auto calibration and lens distortion correction function
- ❑ New user-friendly operation interface
- ❑ Smart operation flow and interface for faster programming
- ❑ Built-in multi-functional developing tools
- ❑ Provides digital I/O and flash control module for various applications
- ❑ Superior hardware specification to same grade products. Achieves high-speed processing
- ❑ High-speed cameras with CameraLink interface
- ❑ Ethernet, RS-232, RS-485 interfaces for data output
- ❑ Passes high industrial standards superior to PC-based systems
- ❑ Built-in PLC communication reduces program compilations
- ❑ Self-defined display and operation interfaces in RUN mode

for Humanization

03
04
09
11
17

Appearance

Features

Applications

Specifications

Dimensions



Appearance

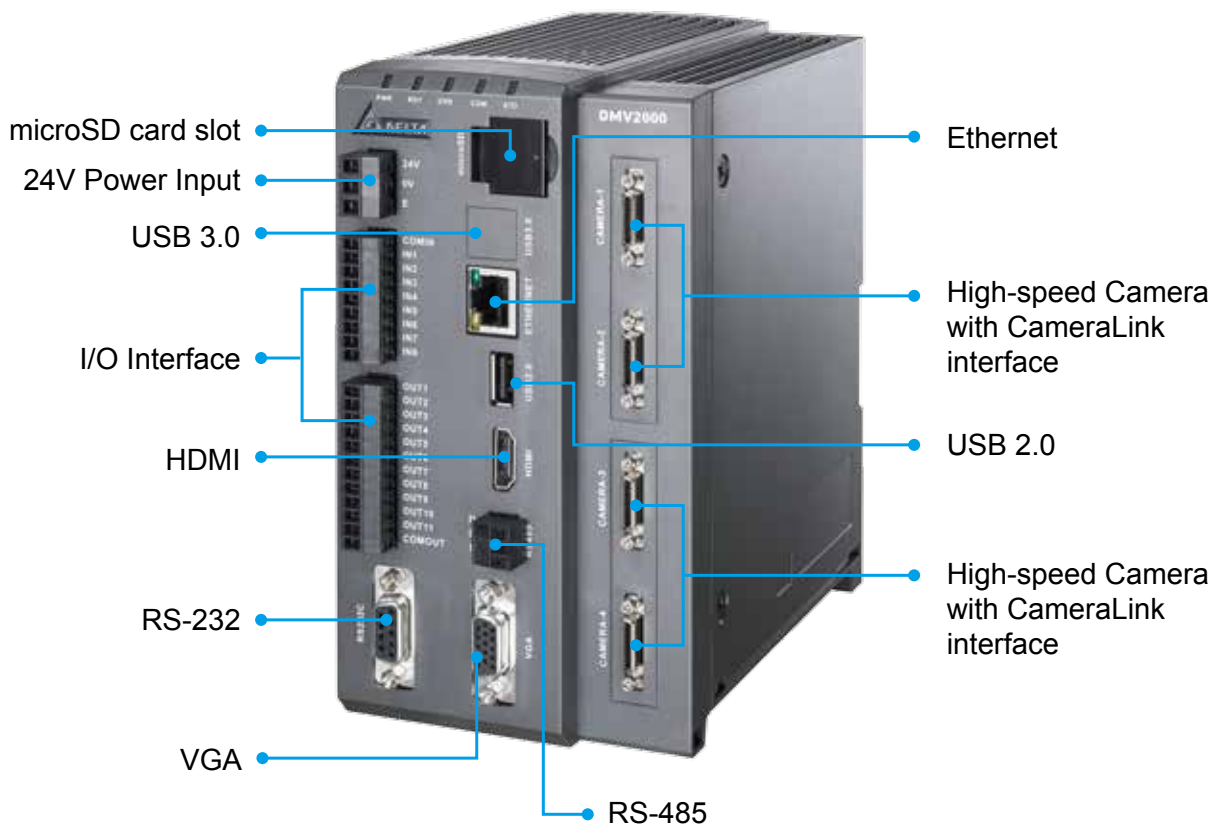

Advanced Functions

Functions				
2D platform positioning	√	Edge position tracing	√	
Pattern matching	√	Edge width tracing	√	
Shape matching	√	Stain inspection	√	
Edge angle	√	OCV	√	
Edge counting	√	Subtle inspection	√	
Edge pitch	√	Color inspection	√	
Edge position	√	Barcode identification	√	
Edge width	√	QR code identification	√	
Area	√	PC applications	Off-line simulation	√
Blob	√		Program upload/ download	√
Image intensity	√		Software update	√

Features

01 Multi-camera system

Allows simultaneous use of several different cameras (Max. 8) for multi-tasking in visual inspection operation



02 High-speed cameras with CameraLink interface

Supports high-speed CameraLink Full configuration with maximum frame rate up to 480 fps
Supports maximum 12M pixels in gray scale and color using standard CameraLink cameras

Resolution (Mega Pixels)		0.3M	2M	4M	5M	12M
Level	Mono	√	√	√	√	√
	Color	√	√	√	√	√
Frame Rate		480 fps	295 fps	159 fps	16 fps	50 fps
Pixel Dimensions (Horizontal x Vertical)		642 × 484	2048 × 1088	2048 × 2048	2448 x 2058	4096 × 3072
Sensor Size		1/3"	2/3"	1"	2/3"	1.76"
Pixel Size (Horizontal x Vertical)		7.4 × 7.4 μm	5.5 × 5.5 μm	5.5 × 5.5 μm	3.45 x 3.45 μm	5.5 × 5.5 μm
Lens Mount		C mount	C mount	C Mount	C Mount	M42

Features

03 New inspection features

Color inspection

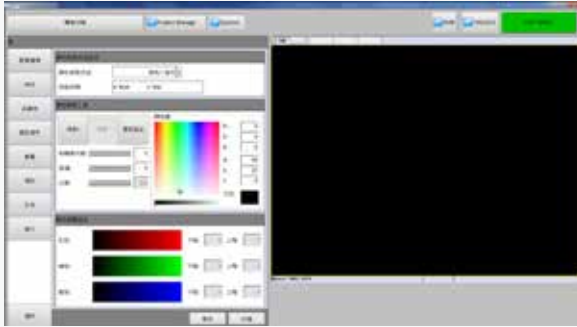

Barcode/ QR code identification



High dynamic range



Lens and perspective distortion calibration

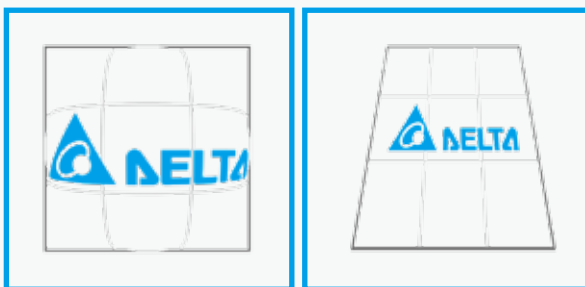

04 Faster processing

- Higher resolution. Enhanced precision in inspection and calculation precision
- Multiple cameras can inspect parallel processes asynchronously
- Greatly enhanced system performance

Inspection, storage, communication and UI operation can work synchronously. Real-time inspection and operation time is minimally affected (It costs a total of 15ms for single trigger input, lighting, image capture, inspection and data output for a 0.3M pixels full area inspection).



05 DMV2000 inspection system

Supports double-buffer (double trigger inputs in one camera depend on camera quantity)

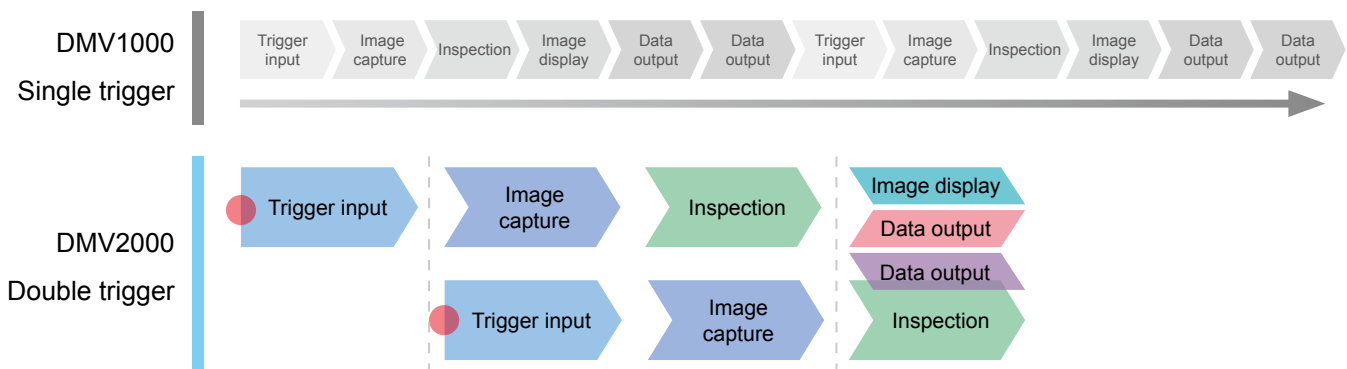

Supports two cameras synchronous trigger input and double core algorithm processing

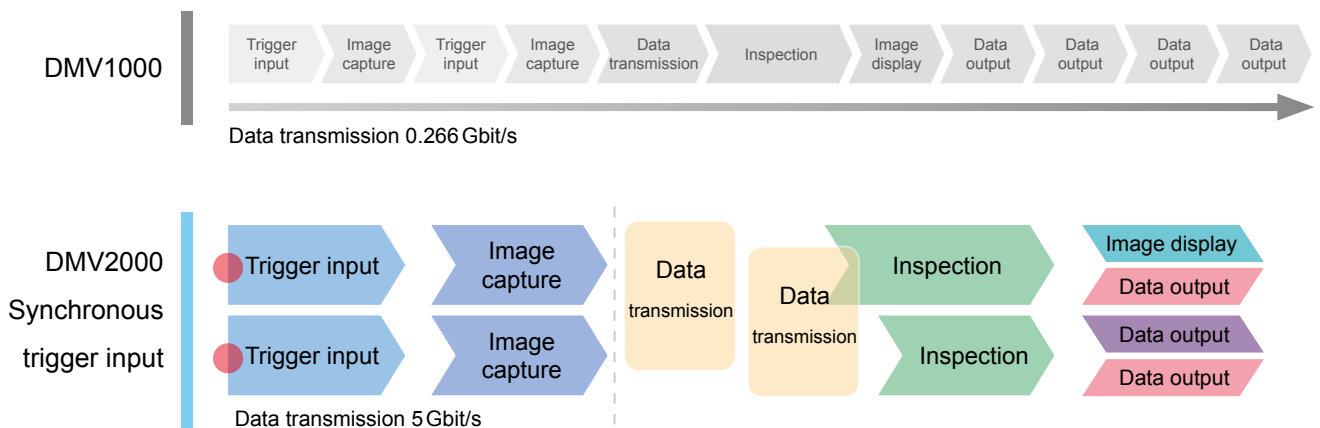

Features

06 Friendly UI and functions

User-friendly interface in operating system

User-friendly UI for convenient operation using mouse and keyboard



White balance color correction

Corrects the color of images through white balance setting.

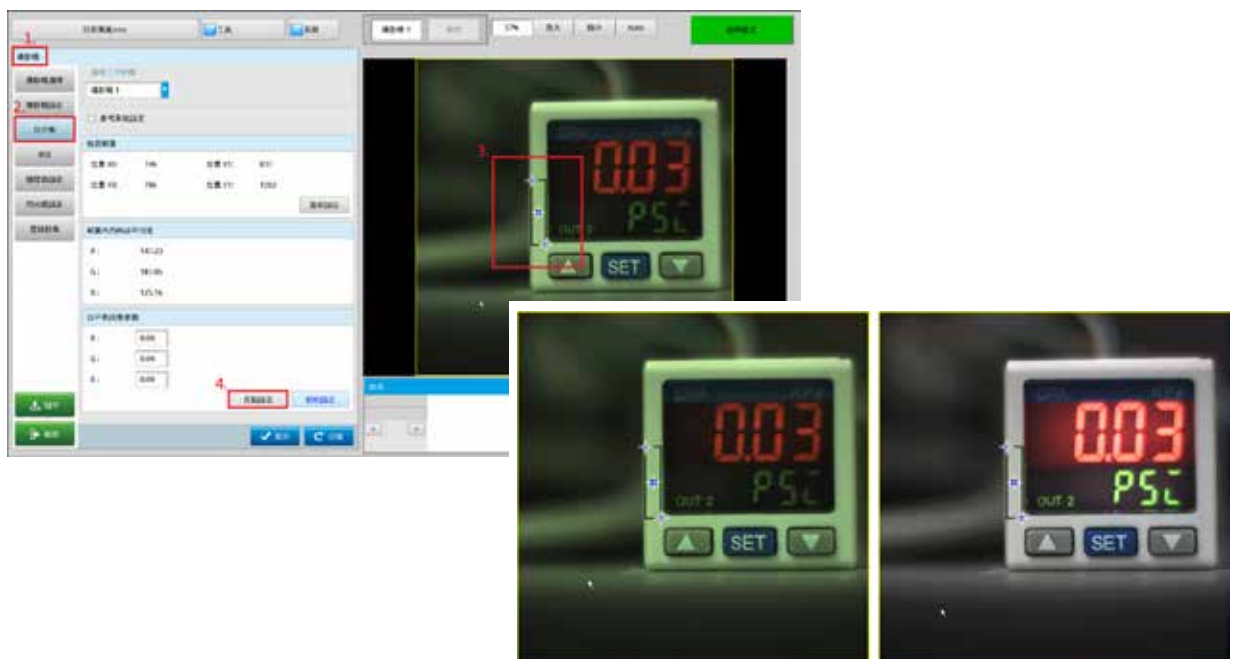

Before

After

Customized RUN mode UI

Provide screen parameter setting tool for self-defined run mode UI

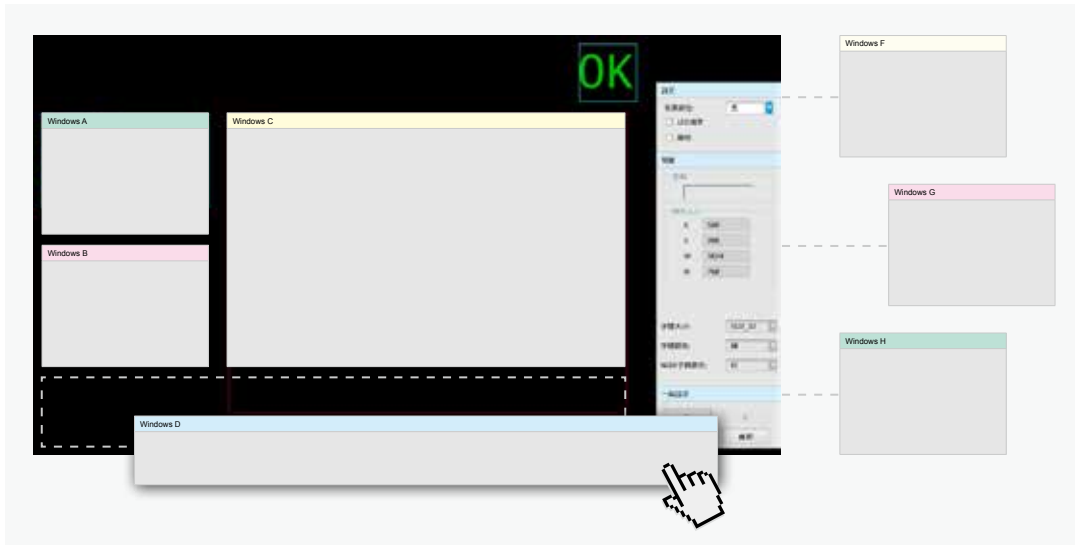

Flexible and expandable module

- **Display output (1080p FHD)**
Triple the visible content of the DMV1000
Supports 15 Pin VGA and HDMI output terminal
- **Digital input/output**
Input/Output pins for flexible self-defined functions
- **Expandable modules**
Flash control
Expanded I/O



Applications

01 Motion Control

Product Pick and Place

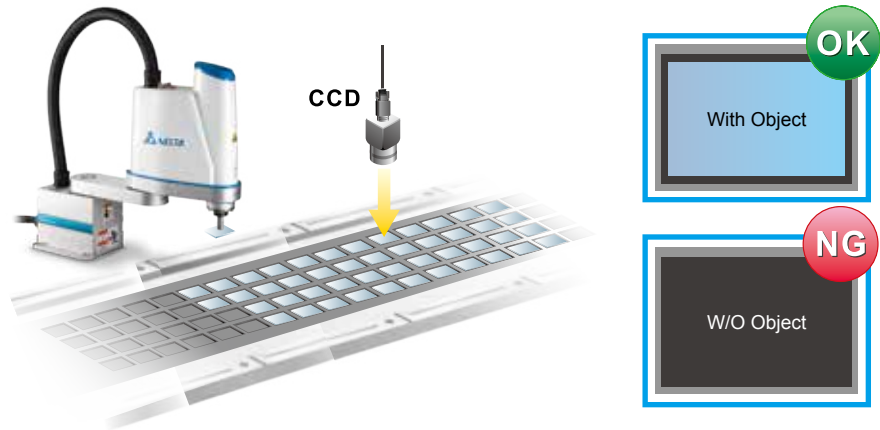

Product Processing and Assembly

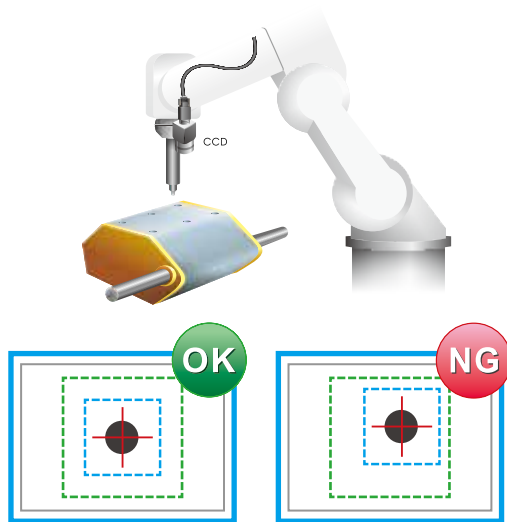

Defect Detection

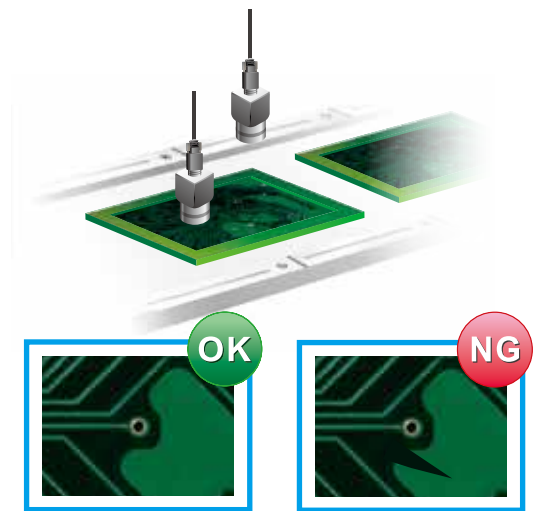

Parts Placement

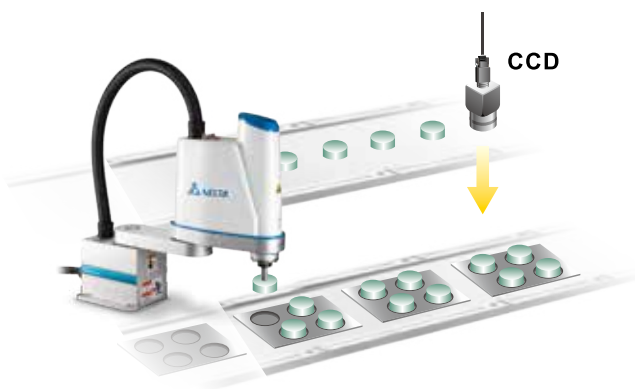

Vision Guided Robotic System (VGRS)

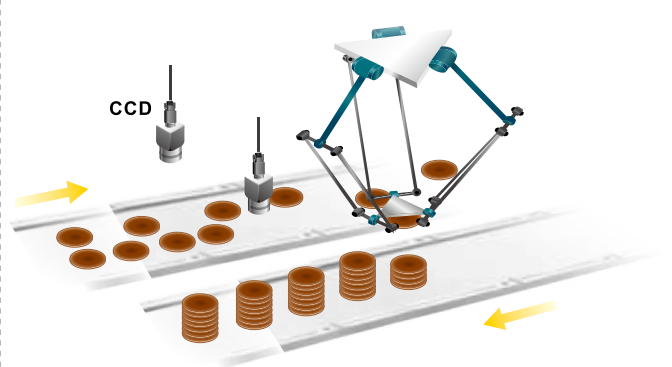

02 Quality Control Inspection

Color Inspection



Product Inspection

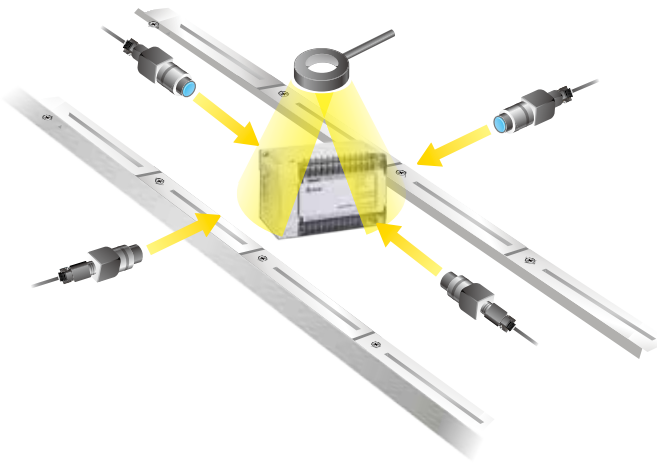

Dimension Gauge

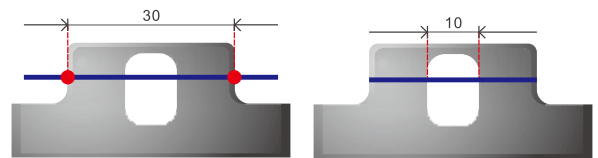

Printing Quality Inspection

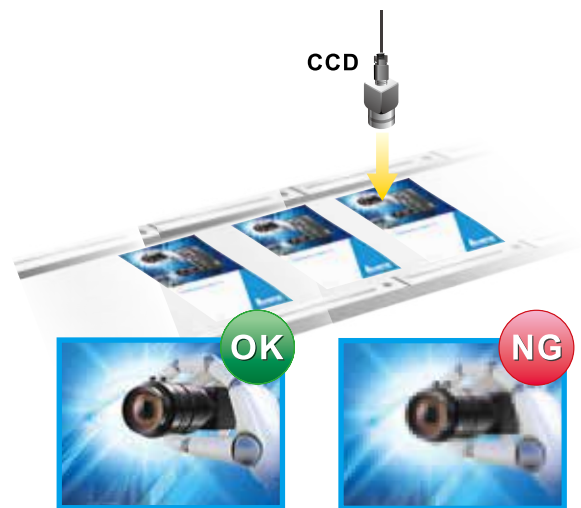

03 Identification

OCV

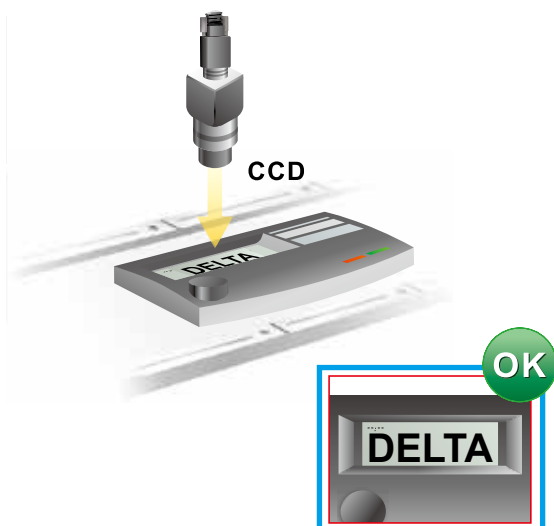

Barcodes Identification

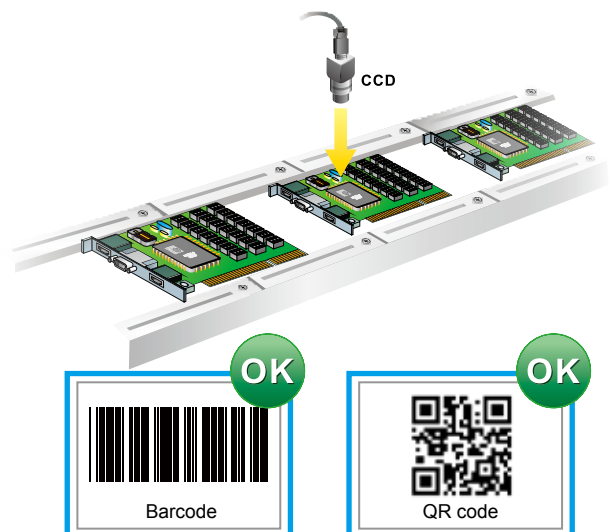

Specifications

► Product Types

Three types for different applications

- **Advanced model:** Maximum 4 or 8 cameras connectable; advanced performance; large storage; supports USB 3.0 and Micro SDXC
- **Standard model:** Maximum 2 or 4 cameras connectable; standard performance; standard storage
- **Basic model:** Maximum 2 cameras connectable; basic performance; basic storage; supports GigE camera

► Controller (DMV2000-CL4-HS/DMV2000-CL2-HS)

Power Supply	24V _{DC}
Operation Voltage Range	Rated Voltage 90% ~110%
Current Consumption	4 Cameras: below 4 A / 2 Camera: below 3.4 A
Vibration Resistance	No error: XYZ 10 to 55Hz 10m/s ² 【1.0 G】 for 10 minutes No damage: XYZ 10 to 55Hz 20m/s ² 【2.0 G】 for 2 hours
Shock Resistance	No error: 200m/s ² 【20 G】 drop 3 times for each 6-surface, 3-edge and 1-corner No damage: 300m/s ² 【30 G】 drop 3 times for each 6-surface, 3-edge and 1-corner
Operating Ambient Temperature	0°C~+45°C
Storage Temperature	-20°C~+65°C
Operating Relative Humidity	35%~85% RH (with no icing or condensation)
Altitude	Under 2000m
Battery Life	5 years

► Camera

Camera	Type	Digital Color/ Gray Scale Camera with CameraLink Interface
	Resolution (Mega Pixels, Horizontal/Vertical)	12M: 4096 (H) X 3072 (V), Base: 13 fps, Full: 50 fps
		4M: 2048 (H) X 2048 (V), Base: 40 fps, Full: 159 fps
		2M: 2048 (H) X 1088 (V), Base: 74 fps, Full: 295 fps
		0.3 M: 642 (H) X 484 (V), Base: 480 fps
	Shutter Speed	25.8μs ~ 45s
	Lens Mount	C mount
	Operation Environment Temperature	0°C~+45°C
	Storage Environment Temperature	-20°C~+65°C
Operation Environment Humidity	35%~85% RH (with no icing or condensation)	
Weight	Approx. 140g	

► Functions and Peripherals

Number of Cameras Connectable		DMV2000-CL4-HS: Max. 4 DMV2000-CL2-HS: Max. 2
Number of Projects		Internal memory: Approx. 6000 projects SD card: based on memory card capacity Supports changeover by I/O and communication (RS-232, RS-485, Ethernet)
Inspection Window	Q'ty	Max. 1000 screens/ project
	Function	2D platform positioning, pattern matching, shape matching, edge angle, edge counting, edge pitch, edge position, edge width, area, blob, image intensity, edge position tracing, edge width tracing, stain inspection, OCV, subtle inspection, color inspection, barcode identification, QR code identification
	ROI Type	Rectangle, Circle, Polygon, Ellipse, Ring, Sector, Rotated Rectangle
	Mask Area	8 areas/ window
Preprocess	Type	Gray out, Dilation, Erosion, Averaging, Median, Laplacian, SobelX, SobelY, Sobel, Subtract, Color extraction, Illumination adjustment, Contrast conversion, Shade correction, self-defined(total 15 types)
Execution Mode		Always Execute, Never Execute, Reference Execute
Numerical Calculation	Q'ty	Max. 1000 screens/ project
	Four Arithmetic Operations	Plus, Subtract, Multiply, Divide
	Functions (71 types)	EQ, NOT_EQ, LT, LE, GT, GE, AND, BIT_AND, OR, BIT_OR, XOR, BIT_XOR, NOT, BIT_NOT, INRANGE, CHOOSE, IF, MAX_INDEX, MIN_INDEX, MAXth_INDEX, MINth_INDEX, ABS, POW, MOD, LOG10, LN, EXP, SQR, SQRT, SUM, TRUNC, ROUND, CEIL, FLOOR, SIN, COS, TAN, ASIN, ACOS, ATAN, ATAN2, RAD, DEG, PI, MAX, AVG, AVG_RANGE, MIN, SDEV, MEDIAN, MODE, LINE_FIT, CIRCLE_FIT, POINT_TO_POINT, POINT_TO_LINE, POINT_TO_CIRCLE, POINT_TO_POINT_DIST, POINT_TO_POINT_ANGLE, LINE_ANGLE, LINE_MIN_ANGLE, LINE_TO_LINE, LINE_TO_CIRCLE, CIRCLE_TO_CIRCLE, BLOB_TO_POINT, BLOB_TO_LINE, BLOB_TO_BLOB, BLOB_TO_POINT_ANGLE, STAIN_TO_POINT, STAIN_TO_LINE, STAIN_TO_STAIN, STAIN_TO_STAIN_ANGLE
Communication Interface		Configurable Input Pins: 8 (High speed use); 24 (normal use) Configurable Output Pins: 11 (High speed use); 38 (normal use) RS-232 (Max.115,200 bps), RS-485 (Max. 230,400 bps) Ethernet (1000 BASE-T / 100 BASE-TX / 10 BASE-T), Delta PLC-Link
Display	Screen	FHD 1920 x 1080 output, XGA 1024 × 768 output
	Scale	5% ~ 1000% adjustable
	Language	Traditional Chinese, Simple Chinese, English and dozens more
Operation Interface	Mouse	standard 3 key
	Keyboard	standard 104 key
Camera Flash		DMV2000-CL4-HS: I/O control, max. 4 settings DMV2000-CL2-HS: I/O control, max. 2 settings
Memory Card		SD Card (Max. 32GB), Class 10

Specifications

► Controller Parts

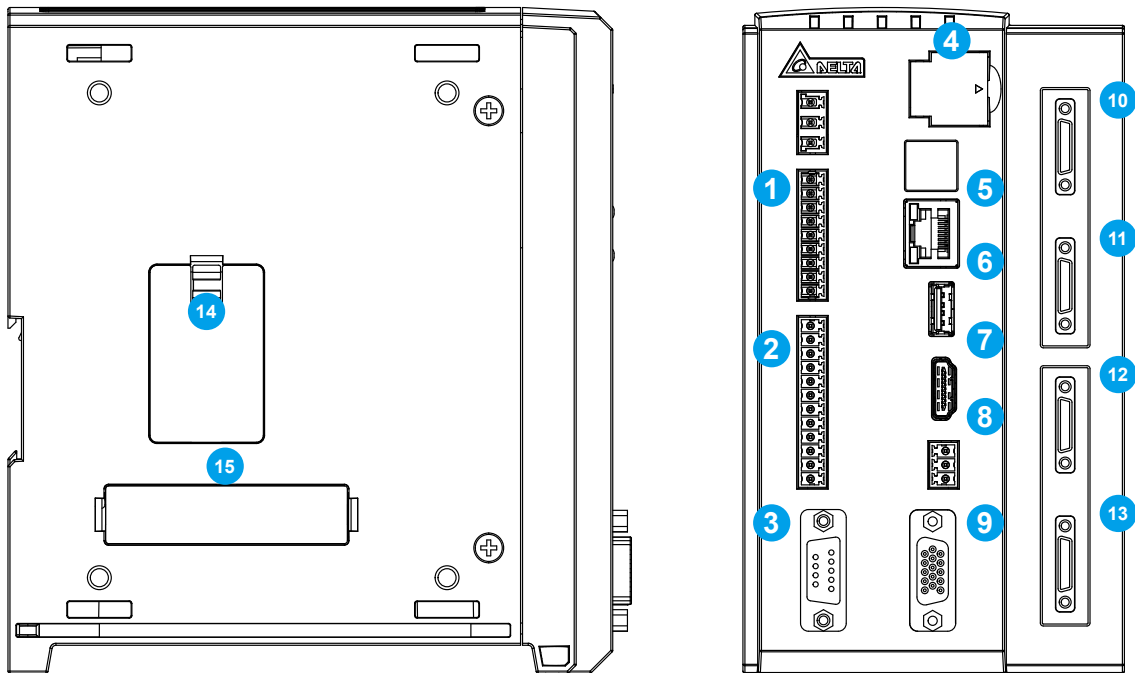

No.	Name	Description
1	Input I/O terminal block	Input terminal (8 pin)
2	Output I/O terminal block	Output terminal (11 pin)
3	RS-232 serial port	Supports Master, Slave serial communication
4	SD memory card	Stores the project settings and images backup
5	Ethernet connector	10/100/1000 BASE-T communication
6	USB 2.0 connector	Mouse, keyboard
7	HDMI output port	Connects to external HDMI monitor
8	RS-485 serial port	Supports Master, Slave serial communication
9	VGA output port	Connects to external VGA monitor
10	Camera 1 connector	Resolution: 0.3M, 2M, 4M, 5M or 12M camera
11	Camera 2 connector	Resolution: 0.3M, 2M, 4M, 5M or 12M camera
12	Camera 3 connector	Resolution: 0.3M, 2M, 4M, 5M or 12M camera
13	Camera 4 connector	Resolution: 0.3M, 2M, 4M, 5M or 12M camera
14	Button cell battery slot	Maintain system time
15	Expansion module slot	Flash control, expanded I/O

Ordering Information

All cameras and cables are for the CameraLink interface

▪ Cameras

DMV-CM30GCL	CMOS CAMERA 0.3M MONO CameraLink
DMV-CM30CCL	CMOS CAMERA 0.3M COLOR CameraLink
DMV-CM2MGCL	CMOS CAMERA 2.0M MONO CameraLink
DMV-CM2MCCL	CMOS CAMERA 2.0M COLOR CameraLink
DMV-CM4MGCL	CMOS CAMERA 4.0M MONO CameraLink
DMV-CM4MCCL	CMOS CAMERA 4.0M COLOR CameraLink
DMV-CD5MGCL	CCD CAMERA 5.0M MONO CameraLink
DMV-CD5MCCL	CCD CAMERA 5.0M COLOR CameraLink
DMV-CM12MGCL	CMOS CAMERA 12M MONO CameraLink
DMV-CM12MCCL	CMOS CAMERA 12M COLOR CameraLink

▪ Controllers

DMV2000-CL4-HS	Standard model controller for maximum 4 cameras connectable
DMV2000-CL2-HS	Standard model controller for maximum 2 cameras connectable

▪ Cameras with 3 m Flexible High-speed cable

DMV-CMA3003GCL	CAMERA CABLE 3M + CMOS 0.3M MONO CameraLink
DMV-CMA3003CCL	CAMERA CABLE 3M + CMOS 0.3M COLOR CameraLink
DMV-CMA2M03GCL	CAMERA CABLE 3M + CMOS 2M MONO CameraLink
DMV-CMA2M03CCL	CAMERA CABLE 3M + CMOS 2M COLOR CameraLink
DMV-CMA4M03GCL	CAMERA CABLE 3M + CMOS 4M MONO CameraLink
DMV-CMA4M03CCL	CAMERA CABLE 3M + CMOS 4M COLOR CameraLink
DMV-CDA5M03GCL	CAMERA CABLE 3M + CCD 5M MONO CameraLink
DMV-CDA5M03CCL	CAMERA CABLE 3M + CCD 5M COLOR CameraLink

▪ Cameras with 5 m Flexible High-speed cable

DMV-CMA3005GCL	CAMERA CABLE 5M + CMOS 0.3M MONO CameraLink
DMV-CMA3005CCL	CAMERA CABLE 5M + CMOS 0.3M COLOR CameraLink
DMV-CMA2M05GCL	CAMERA CABLE 5M + CMOS 2M MONO CameraLink
DMV-CMA2M05CCL	CAMERA CABLE 5M + CMOS 2M COLOR CameraLink
DMV-CMA4M05GCL	CAMERA CABLE 5M + CMOS 4M MONO CameraLink
DMV-CMA4M05CCL	CAMERA CABLE 5M + CMOS 4M COLOR CameraLink
DMV-CDA5M05GCL	CAMERA CABLE 5M + CCD 5M MONO CameraLink
DMV-CDA5M05CCL	CAMERA CABLE 5M + CCD 5M COLOR CameraLink

▪ Cameras with 10 m Flexible High-speed cable

DMV-CMA3010GCL	CAMERA CABLE 10M + CMOS 0.3M MONO CameraLink
DMV-CMA3010CCL	CAMERA CABLE 10M + CMOS 0.3M COLOR CameraLink
DMV-CMA2M10GCL	CAMERA CABLE 10M + CMOS 2M MONO CameraLink
DMV-CMA2M10CCL	CAMERA CABLE 10M + CMOS 2M COLOR CameraLink
DMV-CMA4M10GCL	CAMERA CABLE 10M + CMOS 4M MONO CameraLink
DMV-CMA4M10CCL	CAMERA CABLE 10M + CMOS 4M COLOR CameraLink
DMV-CDA5M10GCL	CAMERA CABLE 10M + CCD 5M MONO CameraLink
DMV-CDA5M10CCL	CAMERA CABLE 10M + CCD 5M COLOR CameraLink

▪ Lenses

DMV-LN06W40	0.4 M 2/3" 6mm
DMV-LN08W40	0.4 M 2/3" 8mm
DMV-LN12W40	0.4 M 2/3" 12mm
DMV-LN16W40	0.4 M 2/3" 16mm
DMV-LN25W40	0.4 M 2/3" 25mm
DMV-LN35W40	0.4 M 2/3" 35mm
DMV-LN50W40	0.4 M 2/3" 50mm
DMV-LN75W40	0.4 M 2/3" 75mm
DMV-LN100W40	0.4 M 2/3" 100mm
DMV-LN05M	2M 2/3" 5mm
DMV-LN06M	2M 2/3" 6mm
DMV-LN08M	2M 2/3" 8mm
DMV-LN12M	2M 2/3" 12mm
DMV-LN16M	2M 2/3" 16mm
DMV-LN25M	2M 2/3" 25mm
DMV-LN35M	2M 2/3" 35mm
DMV-LN50M	2M 2/3" 50mm
DMV-LN12M05	5M 1" 12.5mm
DMV-LN35M05	5M 1" 35mm
DMV-LN50M05	5M 1" 50mm
DMV-LN12M06	6M 1" 12mm
DMV-LN16M06	6M 1" 16mm
DMV-LN25M06	6M 1" 25mm
DMV-LN35M06	6M 1" 35mm
DMV-LN50M06	6M 1" 50mm
DMV-LN28M12	12M F-Mount 28mm
DMV-LN35M12	12M F-Mount 35mm
DMV-LN50M12	12M F-Mount 50mm

▪ Illumination

Illumination	Coaxial	DMV-CX40W (white light)
	Direct ring	DMV-DR6736R (red light) DMV-DR6736W (white light)
	Diffusion board	DMV-DR6736D
	Back light	DMV-BL60R (red light)
	Power supply	DMV-PS12C1 DMV-PS12C2 DMV-CA30P (extension cable)

▪ Flexible High-speed camera cable

DMV-CAF03CL	CameraLink FLEX CABLE 3M
DMV-CAF05CL	CameraLink FLEX CABLE 5M
DMV-CAF10CL	CameraLink FLEX CABLE 10M

3-Pin Power Terminal

No.	Name	Description
1	+24V	Positive power supply
2	0V	Negative power supply
3	E	Grounding

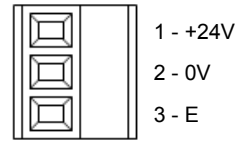

9-Pin Input Terminal

No.	Name	Description
1	COMIN	9-pin input COM
2	IN1 (TRG1)	Camera 1 image capture trigger
3	IN2 (TRG2)	Camera 2 image capture trigger
4	IN3 (TRG3)	Camera 3 image capture trigger
5	IN4 (TRG4)	Camera 4 image capture trigger
6	IN5 (TEST)	Test condition (no data output)
7	IN6 (PLINK)	PLC communication link start sign
8	IN7 (TROFF)	Disable image capture trigger
9	IN8 (ACK)	Controller parallel input handshaking sign

Default Setting

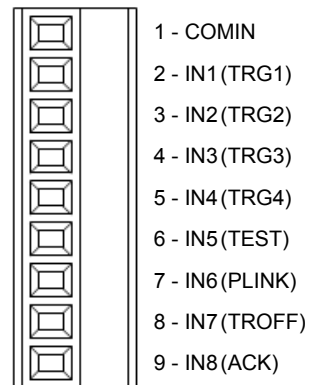

Input Circuit (NPN)

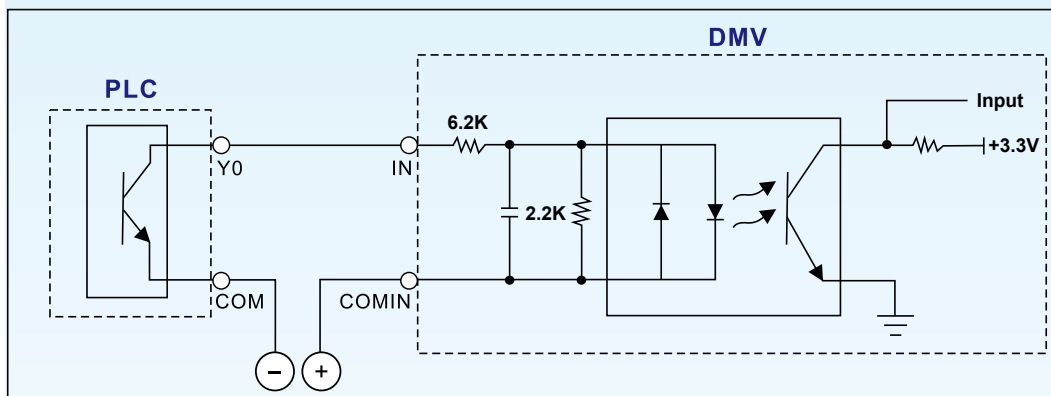

Input Circuit (PNP)

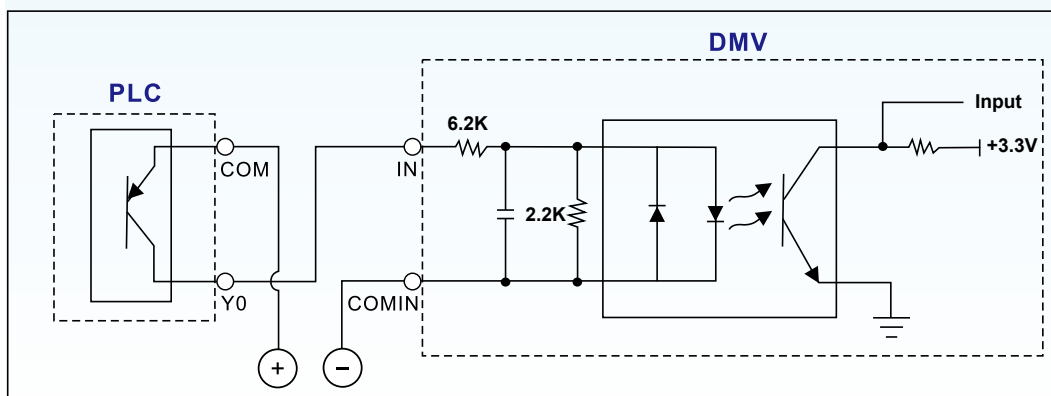

12-Pin Input Terminal

No.	Name	Description
1	OUT1 (RDY)	Enable function switch sign
2	OUT2 (TOUT1)	Total inspection output 1 (synchronous display with operation screen OK/NG)
3	OUT3 (TOUT2)	Total inspection output 2 (synchronous display with operation screen OK/NG)
4	OUT4 (ERROR)	Error sign
5	OUT5 (STR)	Parallel output handshaking sign
6	OUT6 (REN1)	Camera 1 capture image
7	OUT7 (REN2)	Camera 2 capture image
8	OUT8 (REN3)	Camera 3 capture image
9	OUT9 (REN4)	Camera 4 capture image
10	OUT10 (FLH1)	Camera 1 flash output
11	OUT11 (FLH2)	Camera 2 flash output
12	COMOUT	12-pin output COM

Default Setting

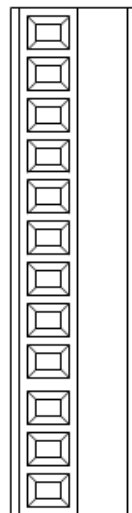

- 1 - OUT1 (RDY)
- 2 - OUT2 (TOUT1)
- 3 - OUT3 (TOUT2)
- 4 - OUT4 (ERROR)
- 5 - OUT5 (STR)
- 6 - OUT6 (REN1)
- 7 - OUT7 (REN2)
- 8 - OUT8 (REN3)
- 9 - OUT9 (REN4)
- 10 - OUT10 (FLH1)
- 11 - OUT11 (FLH2)
- 12 - COMOUT

Output Circuit (NPN output)

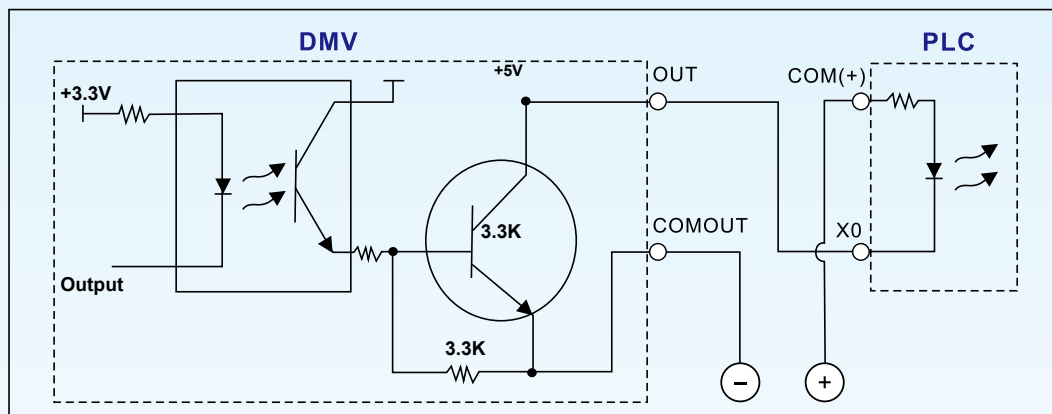

Controller Dimensions

Unit: mm

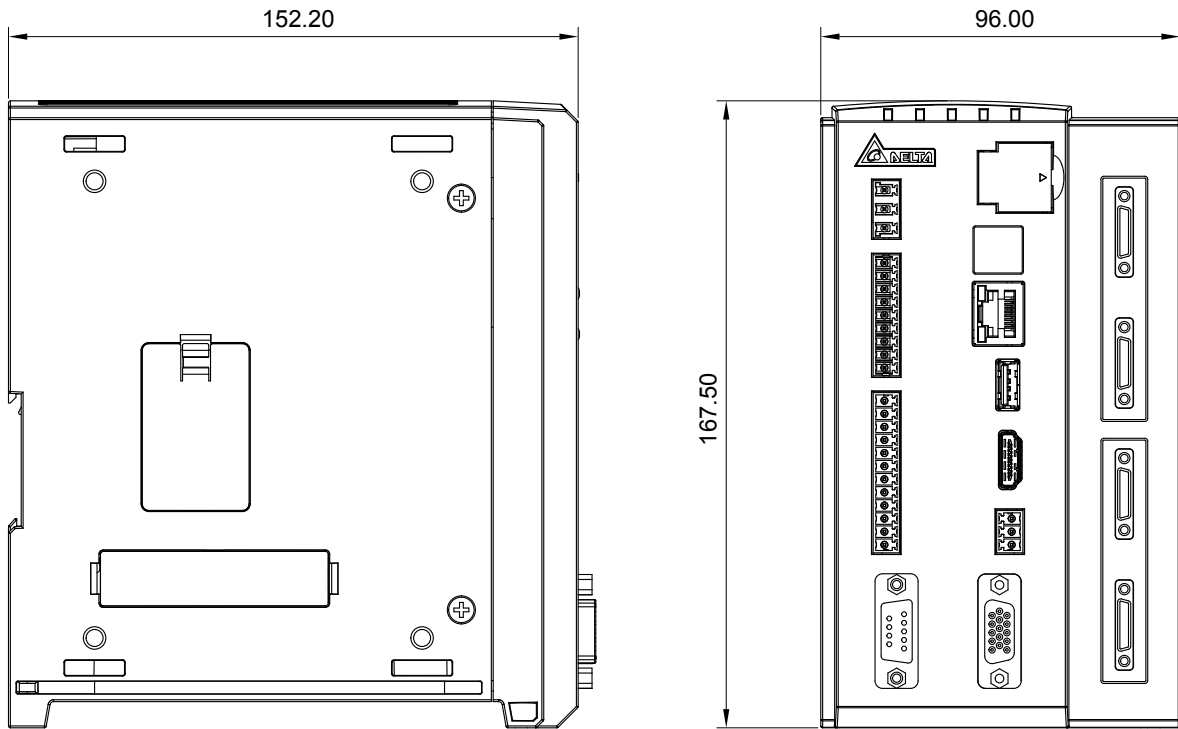

Camera Dimensions

Unit: mm

CCD 5M

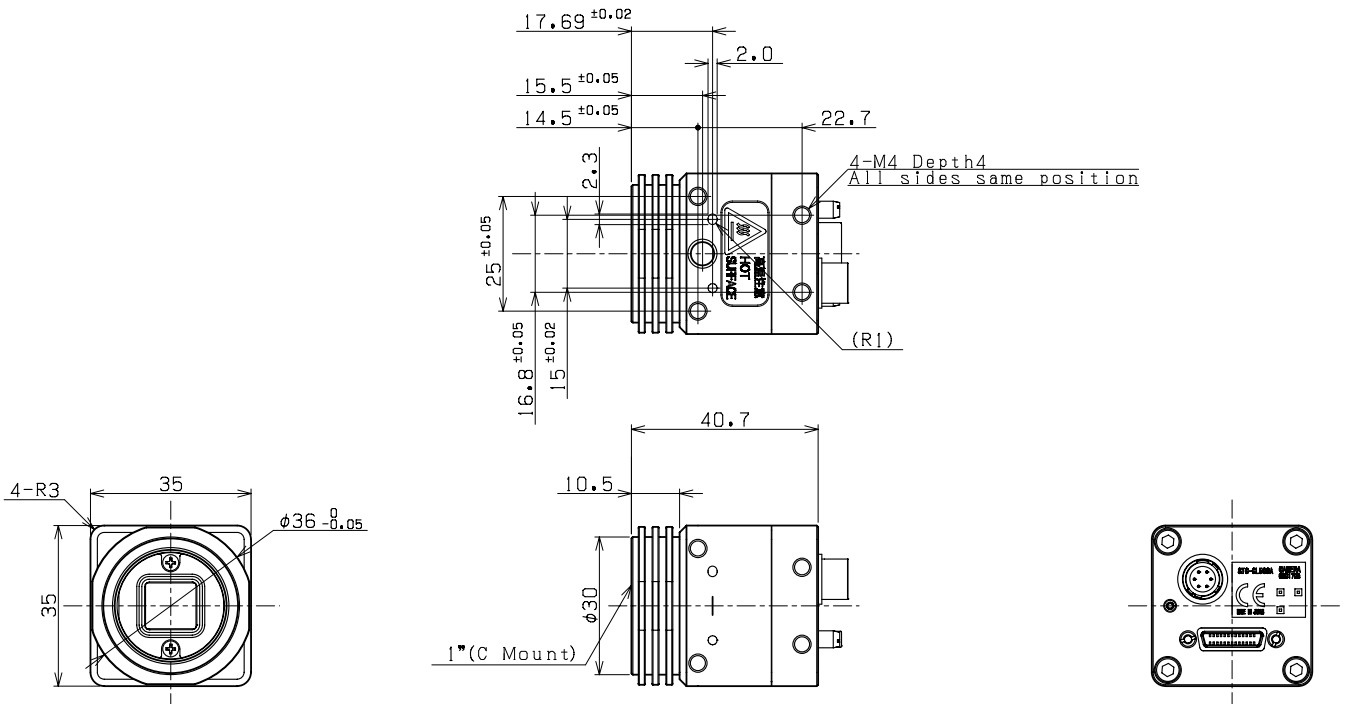

Camera Dimensions

Unit: mm

CMOS 0.3M

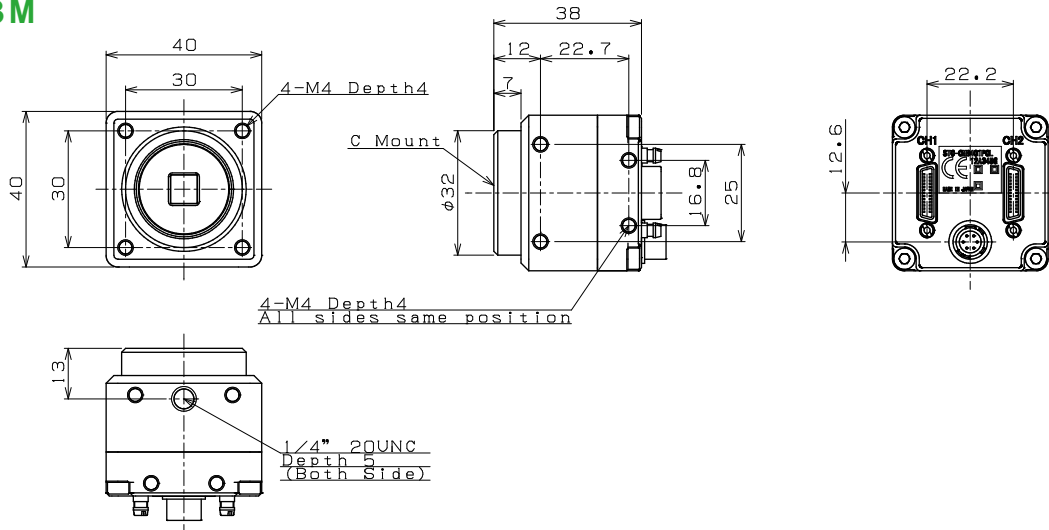

CMOS 2M / 4M

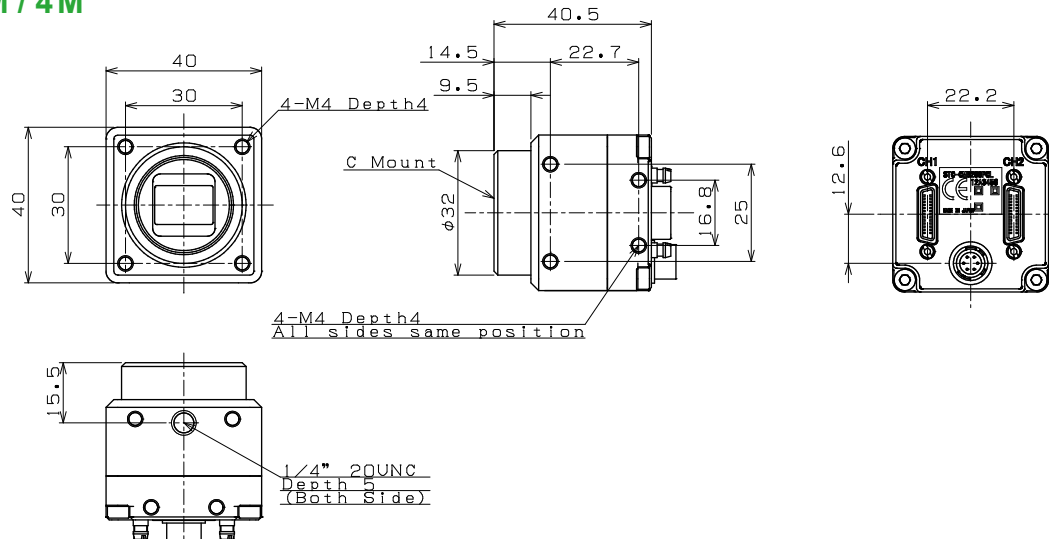

CMOS 12M

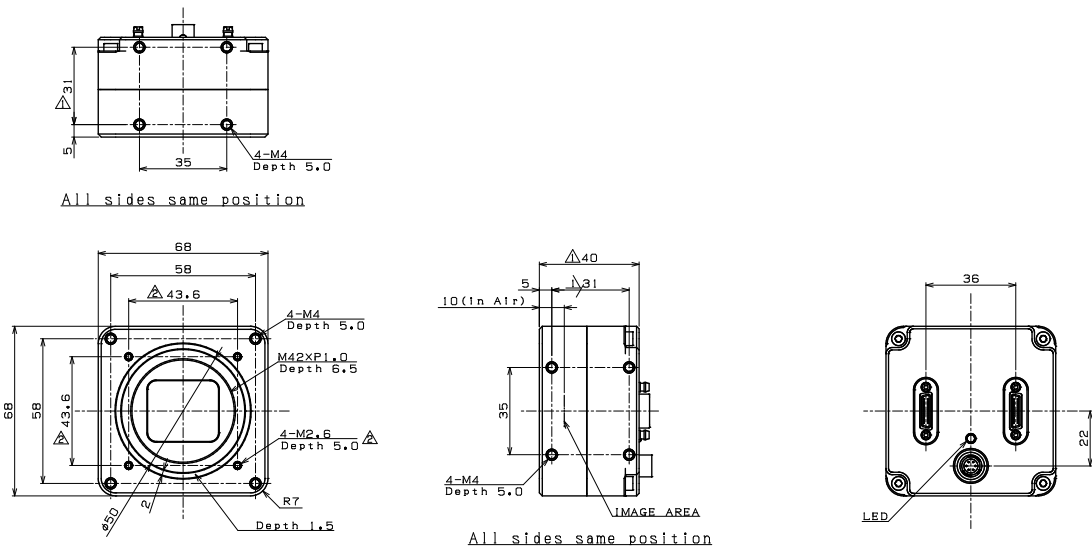



Smarter. Greener. Together.

Industrial Automation Headquarters

Delta Electronics, Inc.

Taoyuan Technology Center
No.18, Xinglong Rd., Taoyuan District,
Taoyuan City 33068, Taiwan
TEL: 886-3-362-6301 / FAX: 886-3-371-6301

Asia

Delta Electronics (Shanghai) Co., Ltd.

No.182 Minyu Rd., Pudong Shanghai, P.R.C.
Post code : 201209
TEL: 86-21-6872-3988 / FAX: 86-21-6872-3996
Customer Service: 400-820-9595

Delta Electronics (Japan), Inc.

Tokyo Office
Industrial Automation Sales Department
2-1-14 Shibadaimon, Minato-ku
Tokyo, Japan 105-0012
TEL: 81-3-5733-1155 / FAX: 81-3-5733-1255

Delta Electronics (Korea), Inc.

Seoul Office
1511, 219, Gasan Digital 1-Ro., Geumcheon-gu,
Seoul, 08501 South Korea
TEL: 82-2-515-5305 / FAX: 82-2-515-5302

Delta Energy Systems (Singapore) Pte Ltd.

4 Kaki Bukit Avenue 1, #05-04, Singapore 417939
TEL: 65-6747-5155 / FAX: 65-6744-9228

Delta Electronics (India) Pvt. Ltd.

Plot No.43, Sector 35, HSIIDC Gurgaon,
PIN 122001, Haryana, India
TEL: 91-124-4874900 / FAX : 91-124-4874945

Delta Electronics (Thailand) PCL.

909 Soi 9, Moo 4, Bangpoo Industrial Estate (E.P.Z),
Pattana 1 Rd., T.Phraksa, A.Muang,
Samutprakarn 10280, Thailand
TEL: 66-2709-2800 / FAX : 662-709-2827

Delta Energy Systems (Australia) Pty Ltd.

Unit 20-21/45 Normanby Rd., Nottling Hill Vic 3168, Australia
TEL: 61-3-9543-3720

Americas

Delta Electronics (Americas) Ltd.

Raleigh Office
P.O. Box 12173, 5101 Davis Drive,
Research Triangle Park, NC 27709, U.S.A.
TEL: 1-919-767-3813 / FAX: 1-919-767-3969

Delta Greentech (Brasil) S/A

São Paulo Office
Rua Itapeva, 26 – 3° Andar - Bela Vista
CEP: 01332-000 – São Paulo – SP - Brasil
TEL: 55-11-3530-8642 / 55-11-3530-8640

Delta Electronics International Mexico S.A. de C.V.

Mexico Office
Vía Dr. Gustavo Baz No. 2160, Colonia La Loma,
54060 Tlalnepantla Estado de Mexico
TEL: 52-55-2628-3015 #3050/3052

EMEA

Delta Electronics (Netherlands) BV

Eindhoven Office
De Witbogt 20, 5652 AG Eindhoven, The Netherlands
MAIL: Sales.IA.EMEA@deltaww.com
MAIL: Sales.IA.Benelux@deltaww.com

Delta Electronics (France) S.A.

ZI du bois Chaland 2 15 rue des Pyrénées,
Lisses 91056 Evry Cedex, France
MAIL: Sales.IA.FR@deltaww.com

Delta Electronics Solutions (Spain) S.L.U

Ctra. De Villaverde a Vallecas, 265 1° Dcha Ed.
Hormigueras – P.I. de Vallecas 28031 Madrid
C/Llull, 321-329 (Edificio CINC) | 22@Barcelona, 08019 Barcelona
MAIL: Sales.IA.Iberia@deltaww.com

Delta Electronics (Italy) Srl

Ufficio di Milano Via Senigallia 18/2 20161 Milano (MI)
Piazza Grazioli 18 00186 Roma, Italy
MAIL: Sales.IA.Italy@deltaww.com

Delta Electronics (Germany) GmbH

Coesterweg 45, D-59494 Soest, Germany
MAIL: Sales.IA.DACH@deltaww.com

Delta Energy Systems LLC (CIS)

Vereyskaya Plaza II, office 112 Vereyskaya str.
17 121357 Moscow, Russia
MAIL: Sales.IA.RU@deltaww.com

Delta Greentech Ltd. (Turkiye)

Serifali Mevkii Barbaros Bulvari Soylesi Sok
No 19 34775, Y.Dudullu-Umraniye/Istanbul
MAIL: Sales.IA.Turkey@delta-emea.com

Delta Energy Systems AG (Dubai BR)

P.O. Box 185668, Gate 7, 3rd Floor, Hamarain Centre,
Dubai, United Arab Emirates
MAIL: Sales.IA.MEA@deltaww.com