



DVPPF02-H2

PROFIBUS DP Slave Communication Module

Application Manual



<http://www.delta.com.tw/industrialautomation>

 **Warning**

- ✓ Please read this instruction carefully before use and follow this instruction to operate the device in order to prevent damages on the device or injuries to staff.
- ✓ Switch off the power before wiring.
- ✓ DVPPF02-H2 is an OPEN TYPE device and therefore should be installed in an enclosure free of airborne dust, humidity, electric shock and vibration. The enclosure should prevent non-maintenance staff from operating the device (e.g. key or specific tools are required for operating the enclosure) in case danger and damage on the device may occur.
- ✓ DVPPF02-H2 is to be used for controlling the operating machine and equipment. In order not to damage it, only qualified professional staff familiar with the structure and operation of DVPPF02-H2 can install, operate, wire and maintain it.
- ✓ DO NOT connect input AC power supply to any of the I/O terminals; otherwise serious damage may occur. Check all the wirings again before switching on the power and DO NOT touch any terminal when the power is switched on. Make sure the ground terminal ⊕ is correctly grounded in order to prevent electromagnetic interference.

 **Table of Contents**

1	INTRODUCTION	3
1.1	Features	3
1.2	Specifications	3
2	PRODUCT PROFILE & OUTLINE	4
2.1	Dimension	4
2.2	Product Profiles	4
2.3	Connecting DVPPF02-H2 to DVP-EH2 Series PLC MPU.....	4
2.4	Installing DVP-EH2 & DVPPF02-H2 on DIN Rail	5
2.5	Connecting to PROFIBUS DP Connection Port	5
2.6	Installation & Wiring.....	6
3	COMMUNICATION	6
3.1	Address Switch	6
3.2	PROFIBUS DP Connection Port	6
3.3	Transmission Distance & Baud Rate.....	7
4	CONTROL REGISTERS.....	7
4.1	Definitions	7
4.2	Data Transmission between DVPPF02-H2 & PROFIBUS DP Master.....	7
4.3	DFROM & DTO Instructions.....	8
5	GSD FILE	9

6	LED INDICATORS & TROUBLE-SHOOTING	10
7	APPLICATION EXAMPLE I.....	10

1 Introduction

1. To ensure correct installation and operation of DVPPF02-H2, please read this chapter carefully before using your DVPPF02-H2.
2. This chapter provides only introductory information on DVPPF02-H2. Details of PROFIBUS DP protocol are not included in this sheet. For more information on PROFIBUS DP protocol, please refer to relevant references or literatures.
3. DVPPF02-H2 is a PROFIBUS DP slave communication module, connecting DVP-EH2 series PLC to PROFIBUS DP network.

1.1 Features

1. Supports loop-type data exchange between PROFIBUS DP master and many slaves.
2. The length of I/O data can be freely configured through PROFIBUS DP network configuration tools.
Max. input data length = 100 words (the sum of 4 slots); Max. output data length = 100 words (the sum of 4 slots).
3. Supports GSD files in PROFIBUS DP network configuration tool.
4. Supports 4 slots in PROFIBUS DP network configuration tool.
5. Auto-detects baud rates; supports Max. 12M bps.

1.2 Specifications

■ PROFIBUS DP connector

Transmission method	High-speed RS-485
Electrical isolation	500VDC
Interface	DB9 connector
Transmission cable	Shielded twisted pair cable

■ Communication

Message type	DPV0, loop-type data exchange
Equipment ID	0AFE (hex)
GSD file	DEL0AFE.GSD
Module name	DVPPF02-H2
Transmission speed (Auto-detect)	9.6 kbps · 19.2 kbps · 93.75 kbps · 187.5 kbps · 500 kbps · 1.5 kbps · 3 Mbps · 6 Mbps · 12 Mbps

■ Environment

Noise immunity	ESD (IEC 61131-2, IEC 61000-4-2): 8KV Air Discharge EFT (IEC 61131-2, IEC 61000-4-4): Power Line: 2KV, Digital I/O: 1KV, Analog & Communication I/O: 1KV Damped-Oscillatory Wave: Power Line: 1KV, Digital I/O: 1KV RS (IEC 61131-2, IEC 61000-4-3): 26MHz ~ 1GHz, 10V/m
Operation/storage	Operation: 0°C ~ 55°C (temperature), 50% ~ 95% (humidity), pollution degree 2 Storage: -25°C ~ 70°C (temperature), 5% ~ 95% (humidity)
Vibration/shock immunity	Standard: IEC61131-2, IEC 68-2-6 (TEST Fc)/IEC61131-2 & IEC 68-2-27 (TEST Ea)
Certificates	IEC 61131-2, UL508

2 Product Profile & Outline

2.1 Dimension

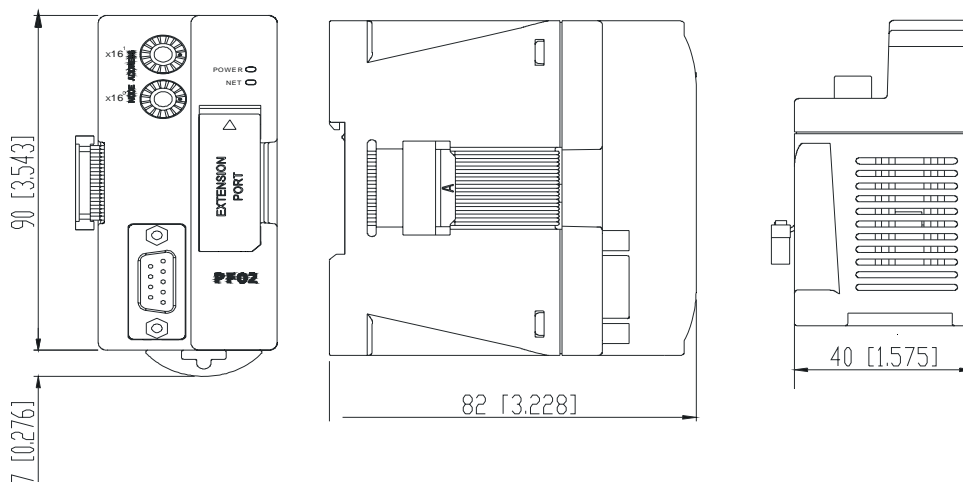

Unit: mm [inch]

2.2 Product Profiles

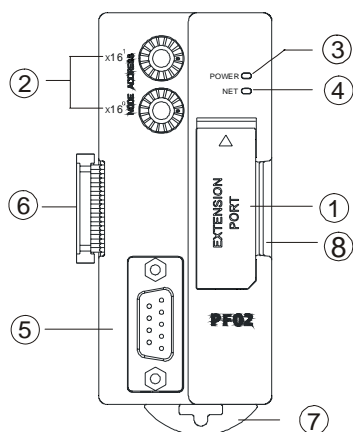

- | | |
|---|-----------------------------|
| ① | Extension port |
| ② | Address switch |
| ③ | POWER indicator |
| ④ | NET indicator |
| ⑤ | PROFIBUS DP connection port |
| ⑥ | Extension module interface |
| ⑦ | DIN rail clip |
| ⑧ | DIN rail |

Extension port:	For connecting to the next H2 series extension module.
Address switch:	For setting up the address of DVPPF02-H2 on PROFIBUS DP network.
POWER indicator:	Indicating whether the power supply is normal.
NET indicator:	Indicating if the connection between DVPPF02-H2 and PROFIBUS DP is normal.
PROFIBUS DP connection port:	Connecting DVPPF02-H2 to PROFIBUS DP network.
Extension module interface:	Connecting DVPPF02-H2 with DVP-EH2 MPU or H2 series extension modules.
DIN rail clip:	Fixing DVPPF02-H2 to DIN rail.
DIN rail:	Installing DVPPF02-H2 to DIN rail.

2.3 Connecting DVPPF02-H2 to DVP-EH2 Series PLC MPU

Switch off DVP-EH2. Open the connection port on the right hand side of DVP-EH2 and connect DVPPF02-H2 to DVP-EH2. Switch on DVP-EH2, and DVP-EH2 will supply power to DVPPF02-H2. There is no need to connect DVPPF02-H2 to an external power supply.

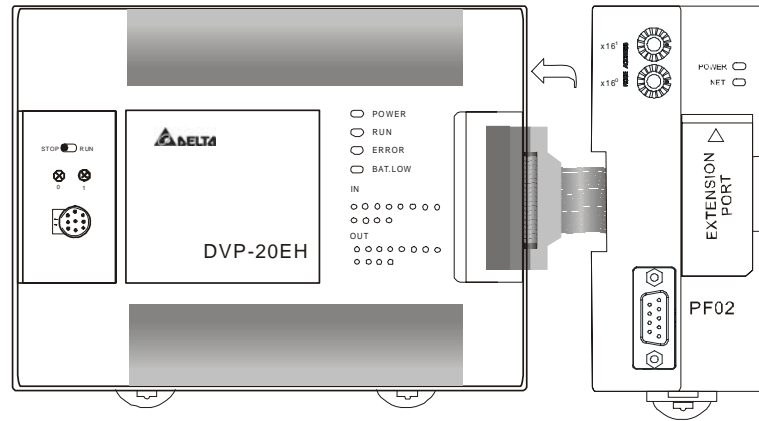

2.4 Installing DVP-EH2 & DVPPF02-H2 on DIN Rail

- Use 35mm DIN rail.
- Open the DIN rail clips on DVP-EH2 and DVPPF02-H2. Insert DVP-EH2 and DVPPF02-H2 on the DIN rail.
- Clip up the DIN rail clips on DVP-EH2 and DVPPF02-H2 to fix DVP-EH2 and DVPPF02-H2 on the DIN rail.

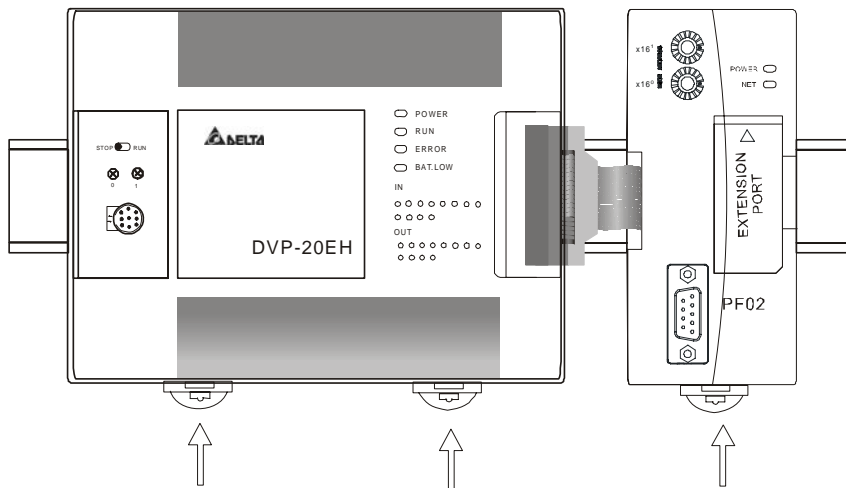

2.5 Connecting to PROFIBUS DP Connection Port

Insert the PROFIBUS DP bus connector into the PROFIBUS DP connection port on DVPPF02-H2. Screw it tight to ensure DVPPF02-H2 and the PROFIBUS DP bus are properly connected.

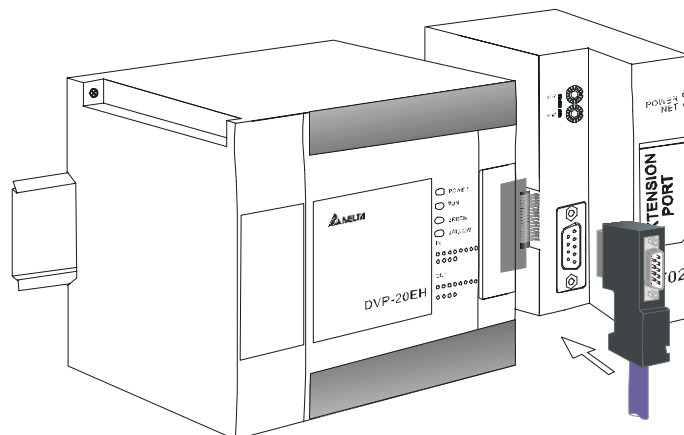

2.6 Installation & Wiring

1. Install DVPPF02-H2 in an enclosure with sufficient space around it to allow heat dissipation (see the figure).
2. DO NOT place the I/O signal wires and power supply wire in the same wiring circuit.

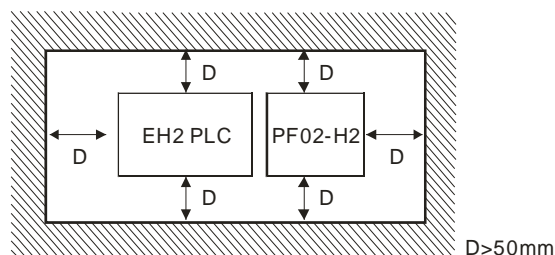

3 Communication

3.1 Address Switch

The address switches are two rotary switches, $x16^0$ and $x16^1$, setting up the node address of DVPPF02-H2 on PROFIBUS DP network. Rotate the switch to a position to indicate the value of the switch. The range for each switch is 0 ~ F. The address switches are in hexadecimal form. The factor of $x16^0$ is 16^0 , and the factor of $x16^1$ is 16^1 . The set value of the address switch is the sum of the value of each of the two switches multiplied by its factor.

Value of address switch	Value at $x16^1$	Value at $x16^0$
Factor of address switch	16^1	16^0

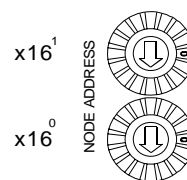

Example: If you need to set the node address of DVPPF02-H2 to “26” (decimal), simply switch $x16^1$ to “1” and $x16^0$ to “A”. 26 (decimal) = $1A$ (hex) = $1 \times 16^1 + A \times 16^0$.

Range for address switch:

Switch setting	Explanation
H'1 ~ H'7D	Valid PROFIBUS DP address
H'0 or H'7E ~ H'FF	Invalid PROFIBUS DP address If the node address is within this range, NET LED will flash quickly in red.

Note:

- Please set up the node address when the power is switched off. After the setup is completed, re-power DVPPF02-H2.
- When DVPPF02-H2 is operating, changing the set value of the node address will be invalid.
- Use slotted screwdriver to rotate the switch carefully in case you scratch the switch.

3.2 PROFIBUS DP Connection Port

PIN	PIN name	Definition	PIN	PIN name	Definition
1	--	N/C	6	VP	Power voltage – positive
2	--	N/C	7	--	N/C
3	RxD/TxD-P	Sending/receiving data P(B)	8	RxD/TxD-N	Sending/receiving data N(A)
4	--	N/C	9	--	N/C
5	DGND	Data reference potential (C)			

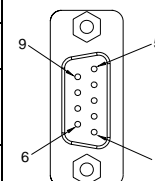

3.3 Transmission Distance & Baud Rate

The communication speed in PROFIBUS DP ranges from 9.6k bps to 12M bps, and the length of transmission cable varies upon the transmission speed. The transmission distance ranges from 100m to 1,200m. See the table below for the baud rates DVPPF02-H2 supports and their corresponding transmission speed.

Baud rate (bps)	9.6k	19.2k	93.75k	187.5k	500k	1.5M	3M	6M	12M
Distance (m)	1,200	1,200	1,200	1,000	400	200	100	100	100

4 Control Registers

4.1 Definitions

The control registers (CR) are the registers inside DVPPF02-H2. See the table below for the definitions of all the CRs. DVP-EH2 series PLC MPU can read or write the CR allowed through DFROM/DTO instructions.

CR#	Attribute	Content	High byte	Low byte
#0	Read	Model name	DVPPF02-H2 model code = H'0250	
#1	Read	Firmware version	Displaying the current firmware version in hex, e.g. V1.00 is indicated as H'0100.	
#2	Read	Length of I/O data	Length of output I/O data	Length of input I/O data
#3 ~ #102	Read/write	Input data mapping	Area for storing data from DVPPF02-H2 to PROFIBUS DP master	
#103 ~ #202	Read	Output data mapping	Area for storing data from PROFIBUS DP master to DVPPF02-H2	
#203 ~ #206			Set up by the system. DO NOT use it.	
#207 ~ #250			Reserved	
#251	Read	Error code	Registers for storing errors. See the error code table in 21.6 for more details.	
#252 ~ #383			Reserved	
#384 ~ #511			Set up by the system. DO NOT use it.	

4.2 Data Transmission between DVPPF02-H2 & PROFIBUS DP Master

Once a PROFIBUS DP network is established, the data written into the data mapping area in PROFIBUS DP will be transmitted automatically to the registers starting from CR#103 in DVPPF02-H2 through PROFIBUS DP bus. The length of data transmitted is decided by the parameter setting, Max. 100 words at a time. The data in the registers starting from CR#3 in DVPPF02-H2 will be transmitted automatically to the data mapping area in PROFIBUS DP master through PROFIBUS DP bus. The length of data transmitted is decided by the parameter setting, Max. 100 words at a time as well. See the table below for the data transmission between DVPPF02-H2 and PROFIBUS DP master.

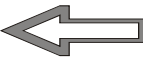
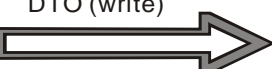
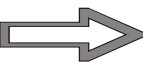
Registers in DVP-EH2 PLC MPU	DFROM/DTO operation	Registers in DVPPF02-H2	Data transmission on PROFIBUS DP	Data mapping area in PROFIBUS DP master
DVP-EH2 reads CR in DVPPF02-H2.	 DFROM (read)	CR#103 ~ #202		Output mapping area in PROFIBUS DP master
DVP-EH2 writes CR in DVPPF02-H2.	 DTO (write)	CR#3 ~ #102		Input mapping area in PROFIBUS DP master

4.3 DFROM & DTO Instructions

1. DVP-EH2 PLC MPU reads or writes data in the CR of DVPPF02-H2 by using DFROM/DTO instruction.

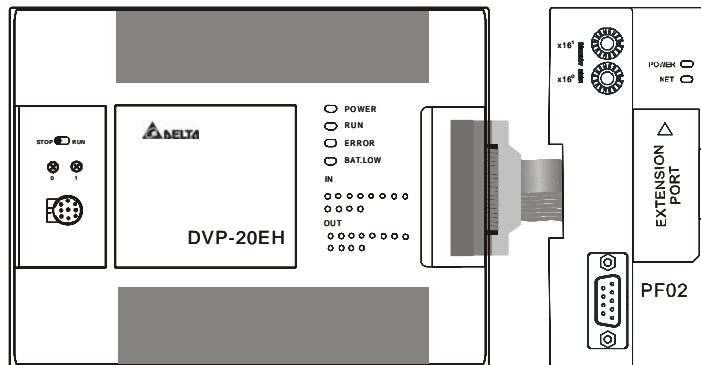

Once DVPPF02-H2 is connected to DVP-EH2 through the connection port, DVP-EH2 will be able to read or write the CR data in DVPPF02-H2 by using DFROM/DTO instruction. The data transmission between DVPPF02-H2 and PROFIBUS DP master is done through PROFIBUS DP bus.

Note: Use DFROM/DTO instruction to read/write data instead of FROM/TO instruction.

2. DFROM & DTO instructions

API 78	DFROM	P	(m1) (m2) (D) (n)	Read CR Data in Special Modules
Operands	(m1) : No. of special module (m2) : CR# in special module to be read (D) : Device for storing read data (n) : Number of data to be read at a time			
Ranges of operands (For DVP-EH2 models only)	(m1) : 0 ~ 7 (m2) : 0 ~ 255 (n) : 1 ~ (255 - (m2)) / 2 when (m2) is odd number. 1 ~ (256 - (m2)) / 2 when (m2) is even number			
Program example	Read CR#103 of special module No.0 into D20 and CR#104 into D21. Only 1 datum is read at a time (n = 1). <pre> X0 --- DFROM K0 K103 D20 K1 </pre>			
API 79	DTO	P	(m1) (m2) (S) (n)	Write CR Data into Special Modules
Operands	(m1) : No. of special module (m2) : CR# in special module to be written (S) : Data to be written in CR (n) : Number of data to be written at a time			
Ranges of operands (For DVP-EH2 models only)	(m1) : 0 ~ 7 (m2) : 0 ~ 255 (n) : 1 ~ (255 - (m2)) / 2 when (m2) is odd number. 1 ~ (256 - (m2)) / 2 when (m2) is even number.			

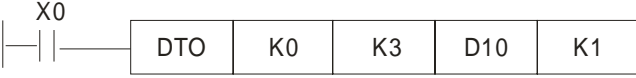
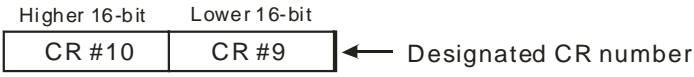
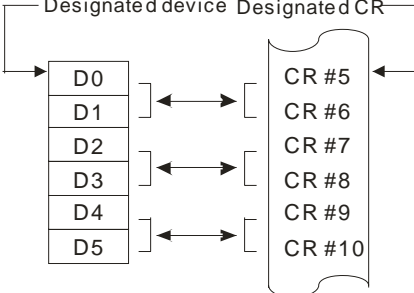
<p>Program example</p>	<p>Write the content in D10 and D11 into CR#3 and CR#4 of special module No.0. Only 1 datum is written in at a time (n = 1).</p> 
<p>Remarks</p>	<p>Operand rules:</p> <ol style="list-style-type: none"> 1. (m1) : The No. of special modules connected to PLC MPU. No. 0 is the module closest to the MPU. Max. 8 modules are allowed to connected to a PLC MPU and they will not occupy any I/O points. 2. (m2) : Start CR#. CR (control register) is the 16-bit memory built in the special module, numbered in decimal as #0 ~ #n. PLC MPU reads or writes data in the CR by DFROM/DTO instruction. 3. DFROM and DTO are 32-bit instructions, reading or writing 2 CRs at a time. <div style="text-align: center; margin: 10px 0;">  </div> 4. Number of data “n” to be transmitted: Due to that DFROM/DTO instruction is 32-bit instruction, the actual number of data read/written should be n×2. The example below is when n = 3. <div style="text-align: center; margin: 10px 0;">  <p>32-bit instruction when n=3</p> </div> <p>M1083 for switching instruction modes in DVP-EH2 series PLC MPU:</p> <ol style="list-style-type: none"> 1. When M1083 = Off, during the execution of DFROM/DTO, all external and timer interruption subroutines will be forbidden. The interruptions within are allowed only after DFROM/DTO finishes its execution. DFROM/DTO <u>CAN</u> also be used in an interruption subroutine. 2. When M1083 = On, during the executino of DFROM/DTO, the interruption occurring will be processed first (with a 100us delay), and the execution of DFROM/DTO will be stopped. After the interruption subroutine finishes its execution, the program will jump to the next instruction. Besides, DFROM/DTO <u>CANNOT</u> be used in an interruption subroutine.

5 GSD File

GSD file is a text file for identifying PROFIBUS DP device (master or slave). GSD file contains required information on configuring a PROFIBUS DP slave on a standard PROFIBUS DP master, including information on the supplier, baud rates supported, I/O signals available. GSD file is the basic tool recording the parameters

of the master. When DVPPF02-H2 is used as PROFIBUS DP slave, you have to add the GSD file of DVPPF02-H2 into the configuration tool of PROFIBUS DP master. The GSD file of DVPPF02-H2 is available for download at Delta's website <http://www.delta.com.tw/>.

6 LED Indicators & Trouble-shooting

There are two LED indicators on DVPPF02-H2, POWER LED and NET LED. POWER LED displays whether the power supply of DVPPF02-H2 is normal. NET LED displays whether the communication of DVPPF02-H2 is connected normally.

■ POWER LED

LED status	Indication	How to correct
Green light steady on	The power is normal.	--
Off	No power	1. Check if the power of DVP-EH2 is normal. 2. Check if the connection between DVPPF02-H2 and DVP-EH2 is normal.

■ NET LED

LED status	Indication	How to correct
Off	No power	1. Check if the power of DVP-EH2 is normal. 2. Check if the connection between DVPPF02-H2 and DVP-EH2 is normal.
Red light steady on	DVPPF02-H2 is operating but is not connected to PROFIBUS DP network.	Check if DVPPF02-H2 is normally connected to PROFIBUS DP bus.
Red light flashes	Depending on the value in CR#251	See the error code table below for how to correct.
Green light steady on	DVPPF02-H2 is in data exchange status	--

■ Error codes

Code	Description	How to correct
00	DVPPF02-H2 operates normally.	--
01	Hardware error	Send your DVPPF02-H2 back to the manufacturer for repair.
02	PROFIBUS DP watch dog error	Check if DVPPF02-H2 is normally connected to PROFIBUS DP bus.
03	Address setting error (0, or exceeding 0x01 ~ 0x7D)	Set the address of DVPPF02-H2 to be within the range 0x01 ~ 0x7D and re-power DVP-EH2.
04	24V low voltage error	Check if the power supply voltage of DVP-EH2 is normal, and check if DVPPF02-H2 is normally connected to DVP-EH2.
05	5V low voltage error	Send your DVPPF02-H2 back to the manufacturer for repair.

7 Application Example I

◆ Target

Complete data exchange between S7-300 (Siemens PLC) and DVP-EH2 (Delta PLC) through PROFIBUS DP network.

◆ Establishing PROFIBUS DP network by DVPPF02-H2 (hardware configuration)

1. Establish the network including S7-300 and DVPPF02-H2 by PROFIBUS DP bus, S7-300 as master and DVPPF02-H2 as slave.

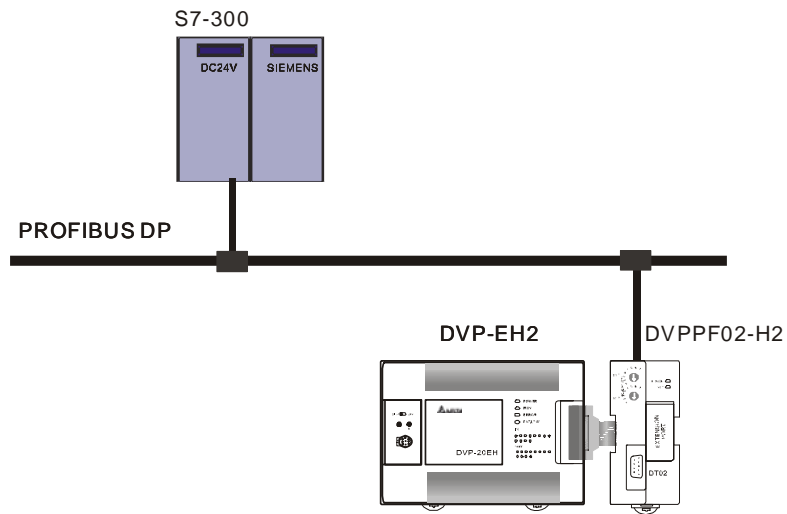

2. Set the address of DVPPF02-H2 to "11" (decimal). See "21.3.1 Address Switch" section for how to set up the address.
After the address is set, re-power DVP-EH2.
3. Check and make sure S7-300, DVP-EH2 and DVPPF02-H2 all operate normally and the wiring of the entire network is correct.

◆ Configuring DVPPF02-H2 on PROFIBUS DP (software configuration)

- Establishing a new file by "Project Wizard".
 1. Open SIMATIC Manager software.

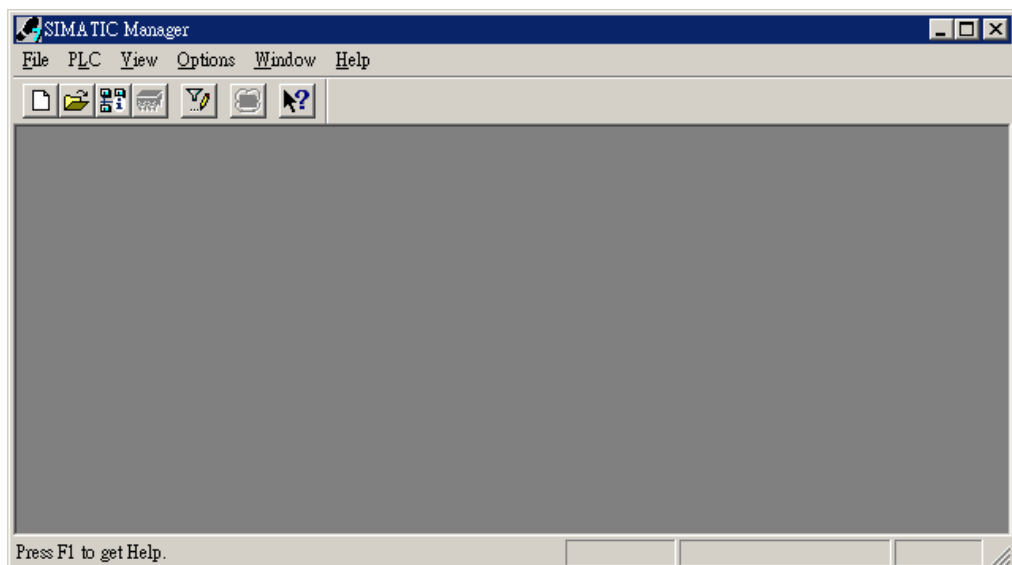

2. Select "File" => "New Project Wizard...".

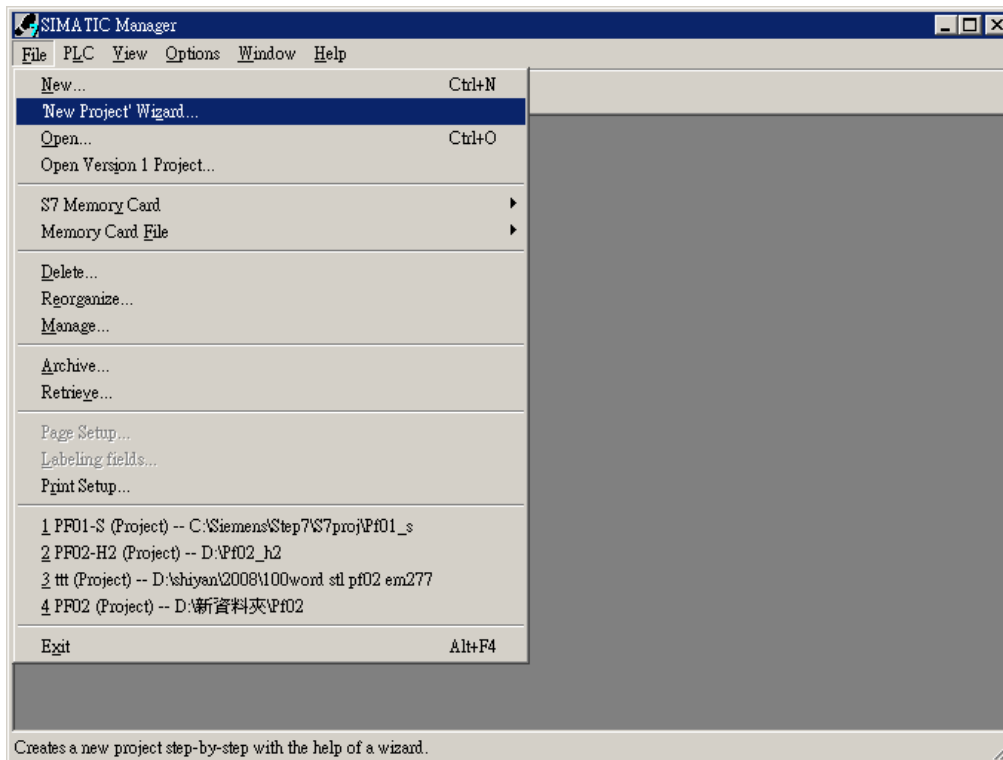

3. Click on "Next".

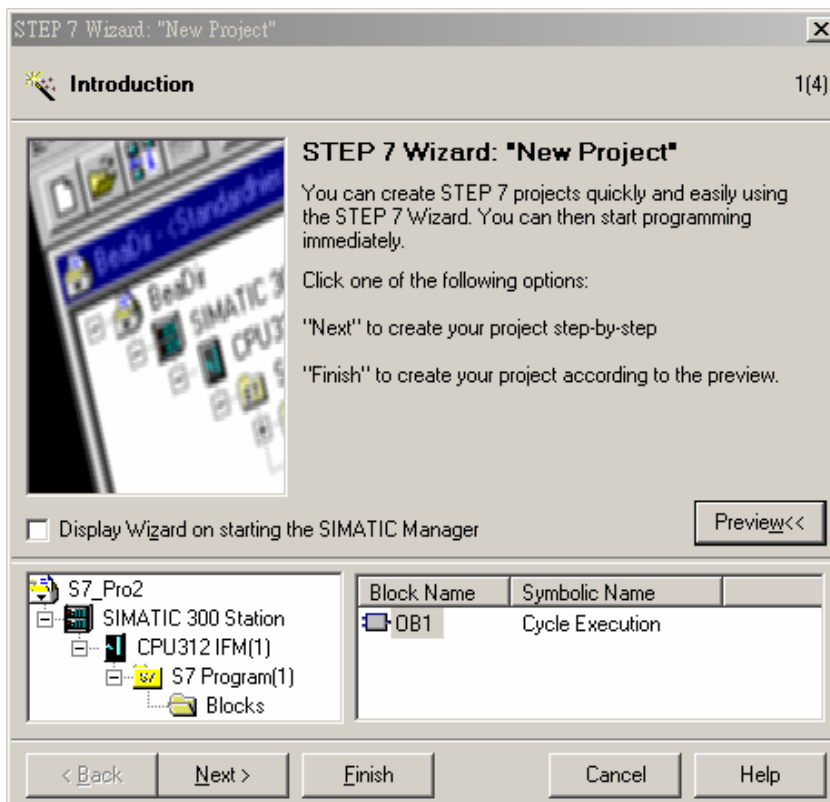

4. Select CPU of S7-300 and click on "Next".

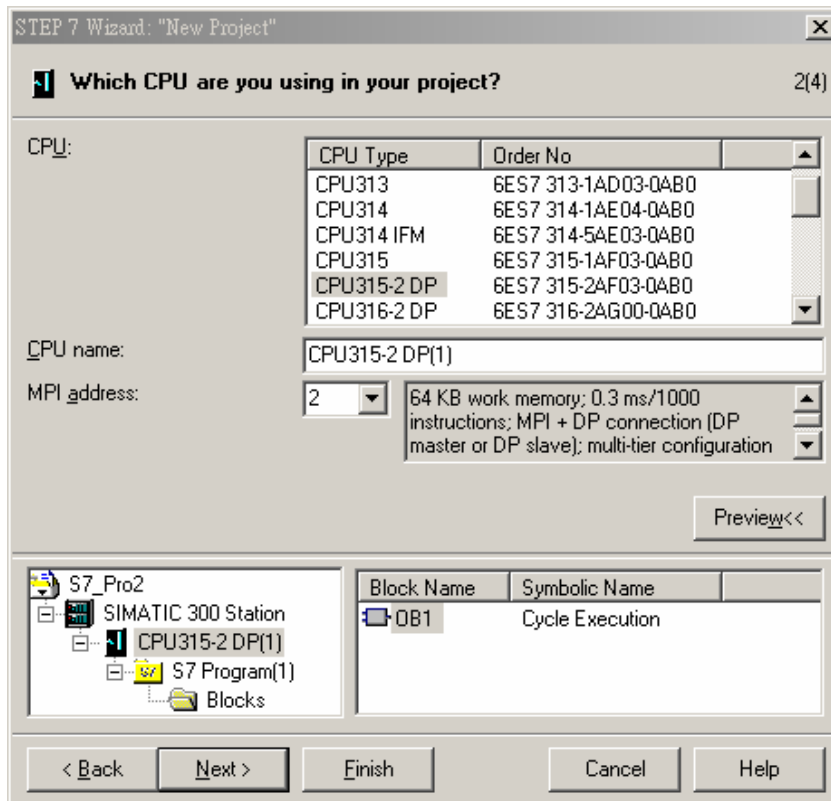

5. Select the block and the language for selected block, and click on "Next".

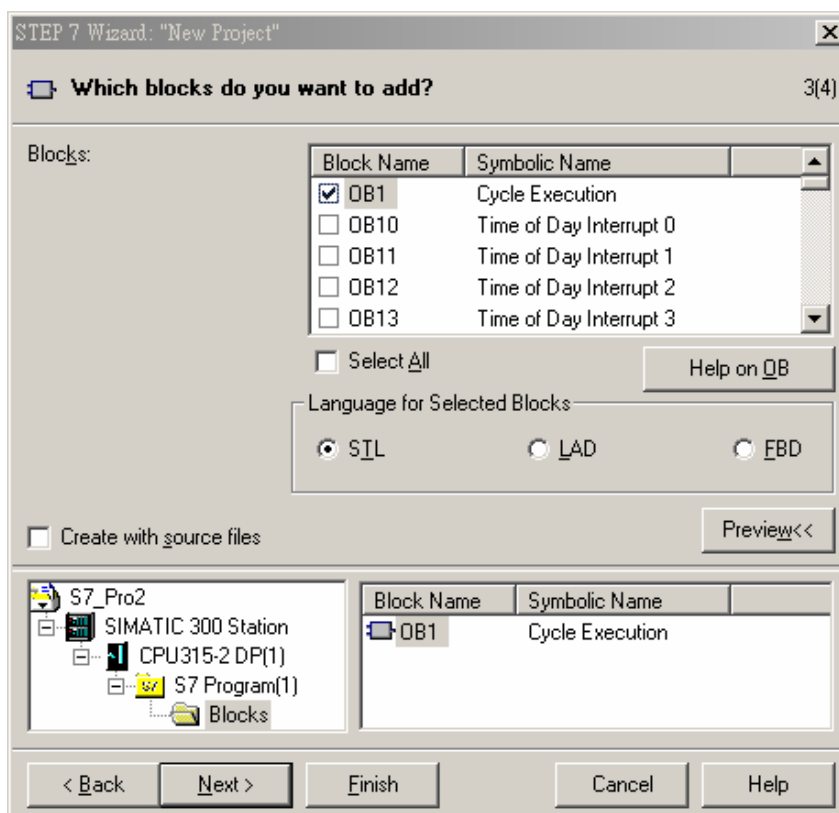

6. Enter the project name and click on "Finish".

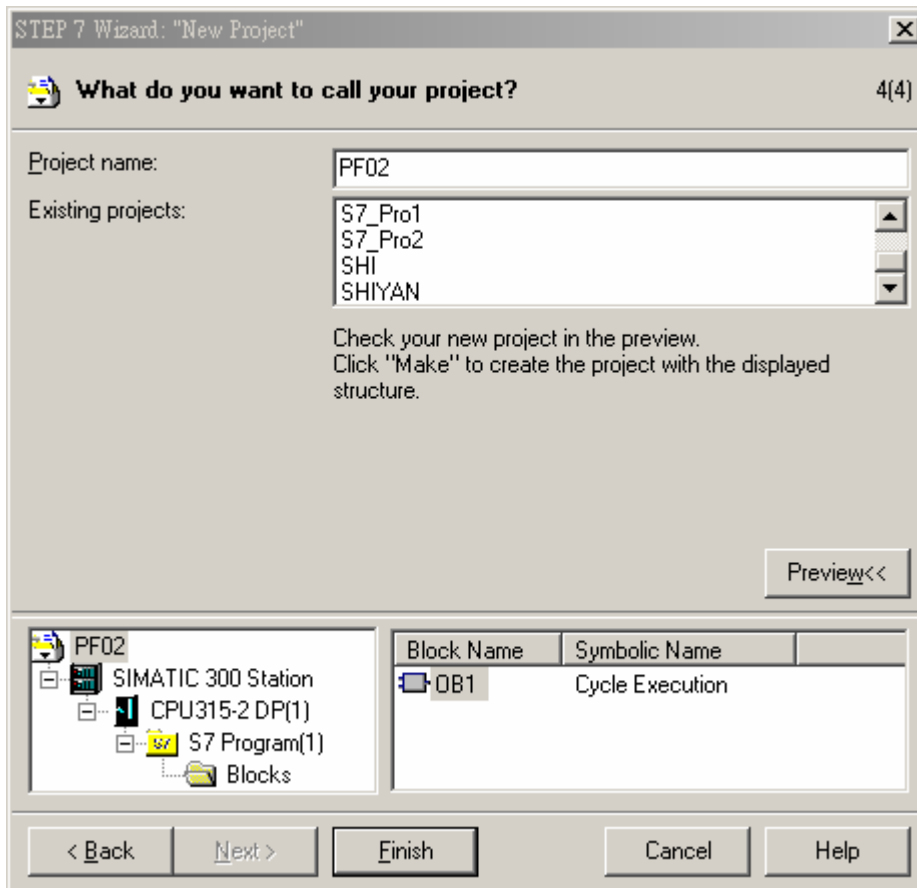

7. You will then see a new window indicating that a new project has been created.

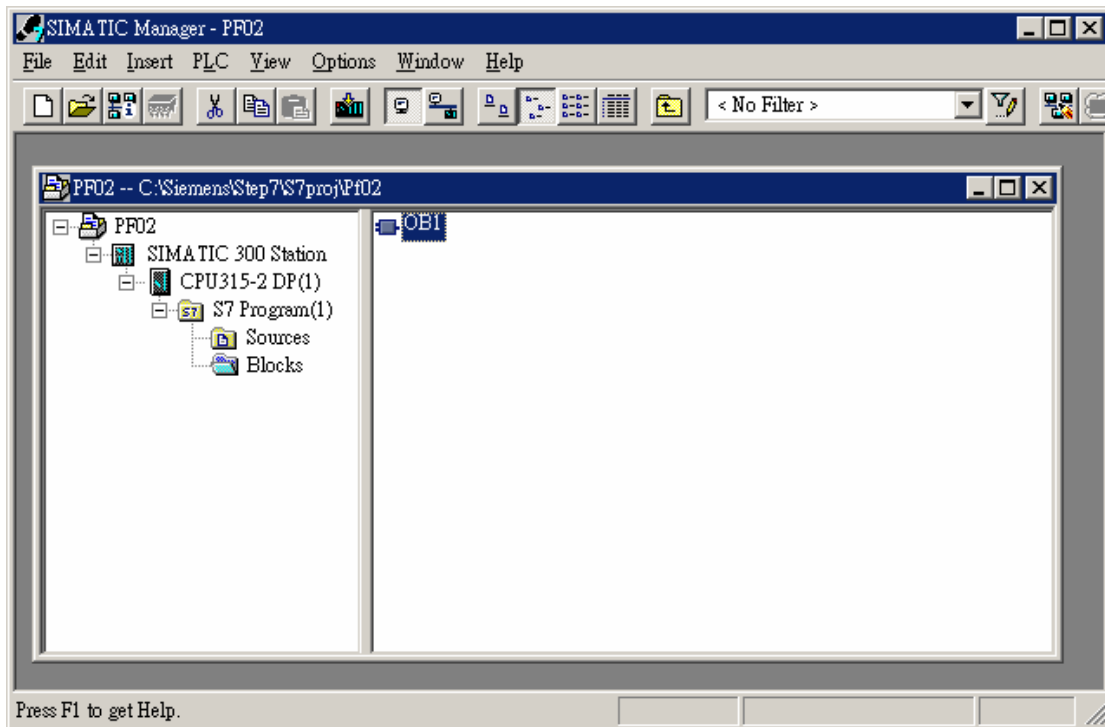

■ Creating PROFIBUS DP bus

1. Select "SIMATIC 300 Station" in the created project. Double click on "Hardware" in the right column, and a new "HW Config" window will appear.

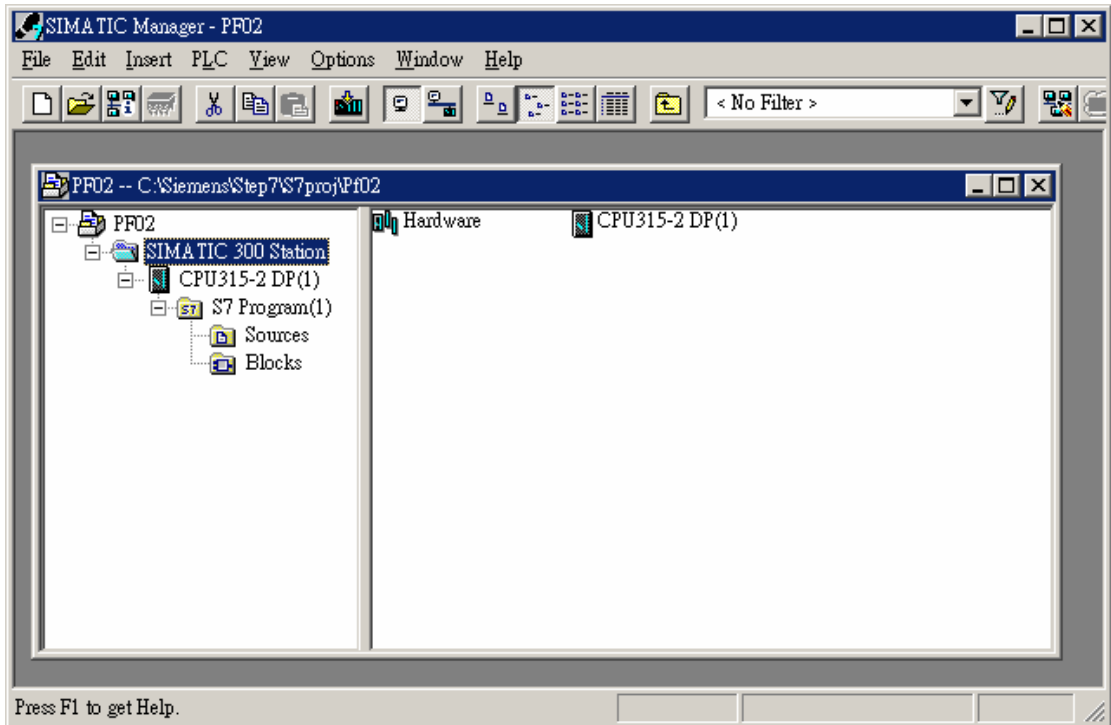

- In the “HW Config” window, double click on “DP” in the table of the left column, and you will see a new dialog box appearing.

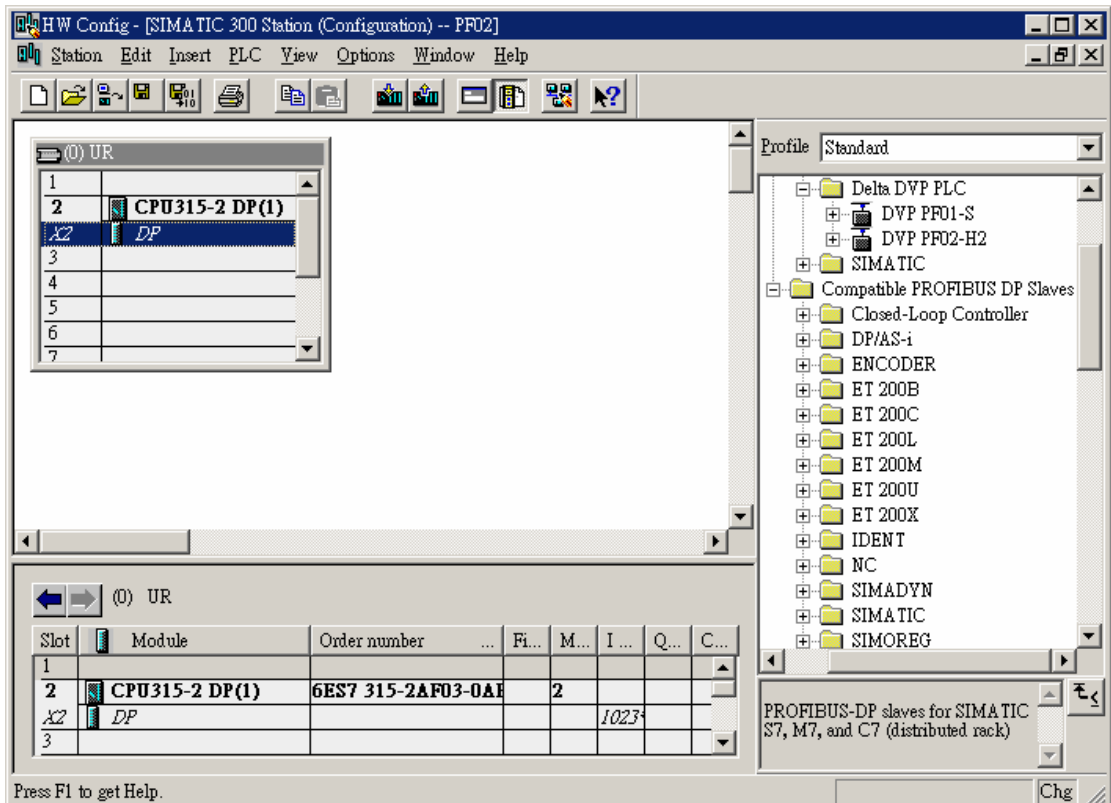

- Click on “Properties” on the dialog box, and another new dialog box will appear.

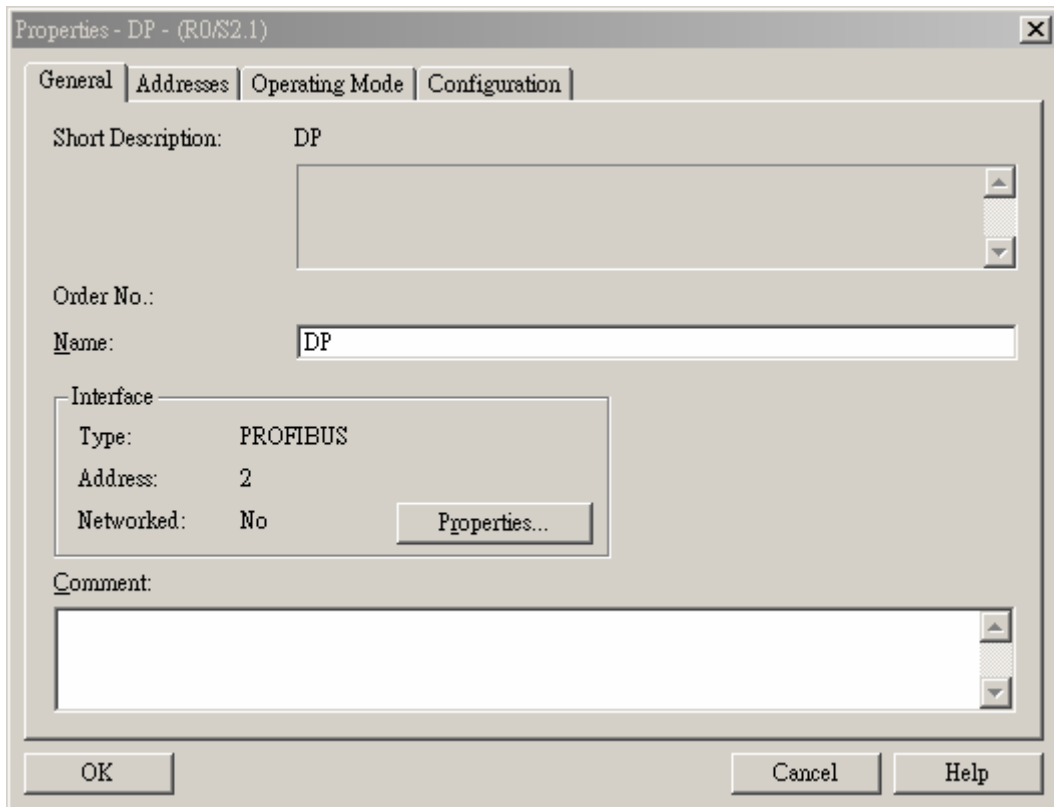

4. Select "Address" as the address of the master. Next, click on "New", and you will see a new dialog box appearing.

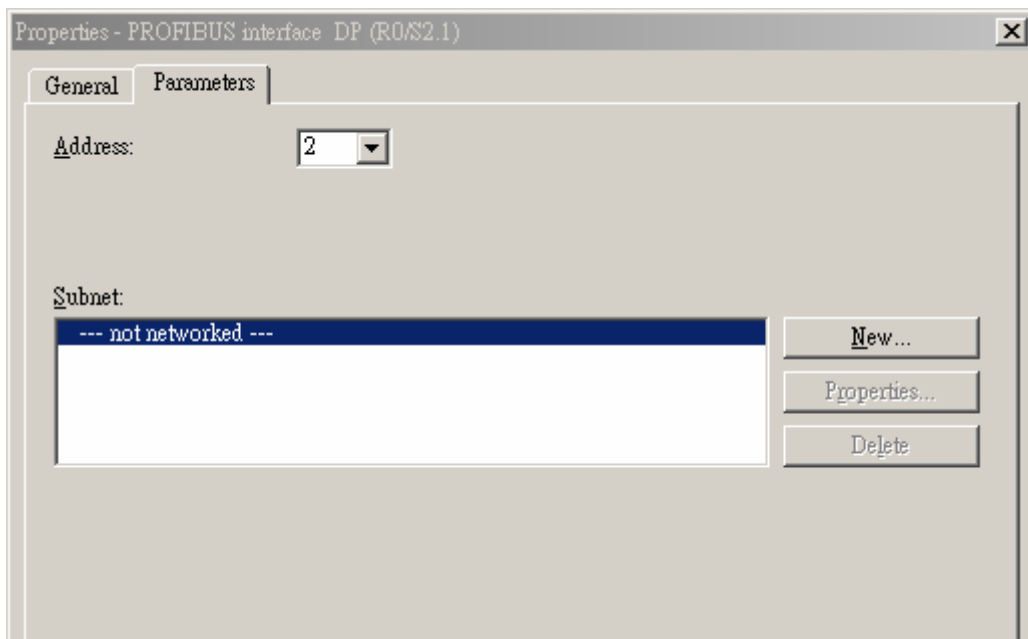

5. Select "Transmission Rate" and "Profile" and click on "OK".

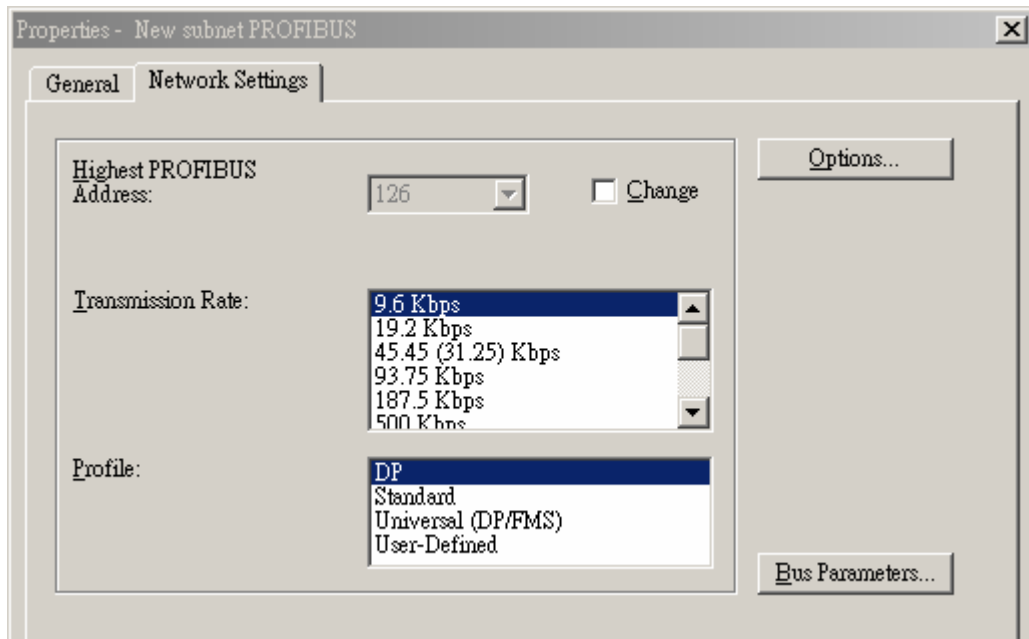

- Once all the parameters are set, a PROFIBUS DP bus will be created after the UR.

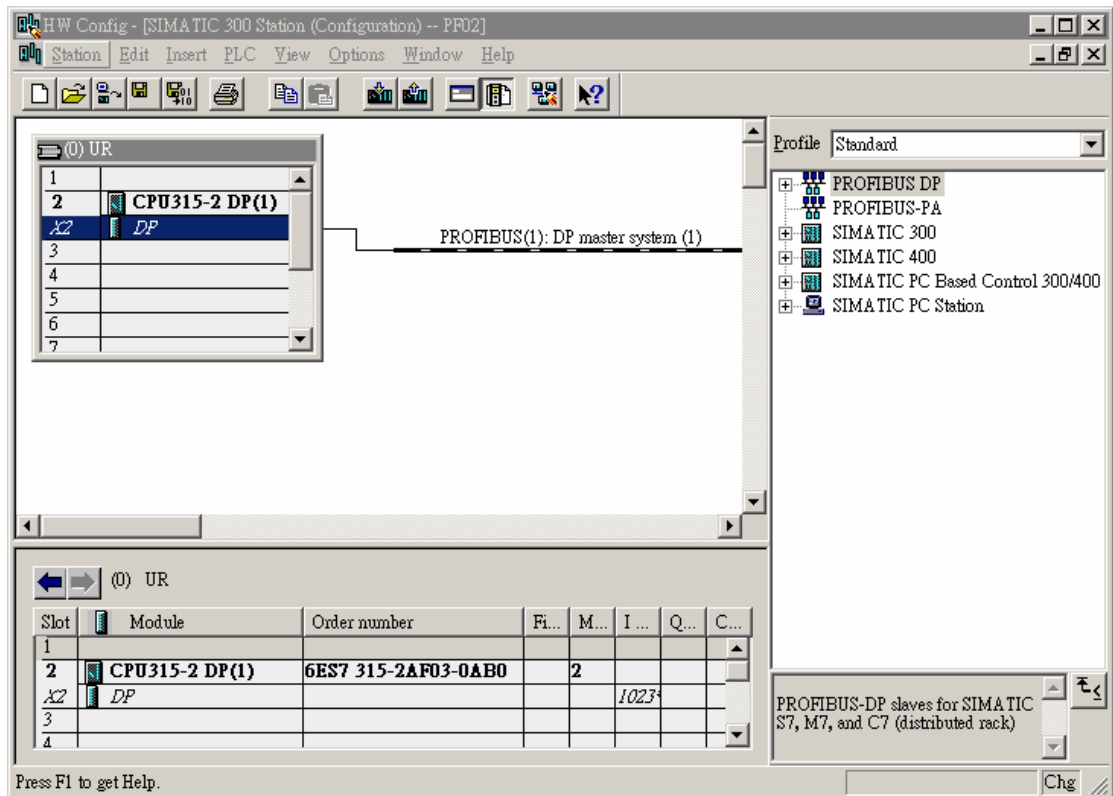

- Creating GSD file

- Select "Options" => "Install New GSD" in the "HW Config" window.

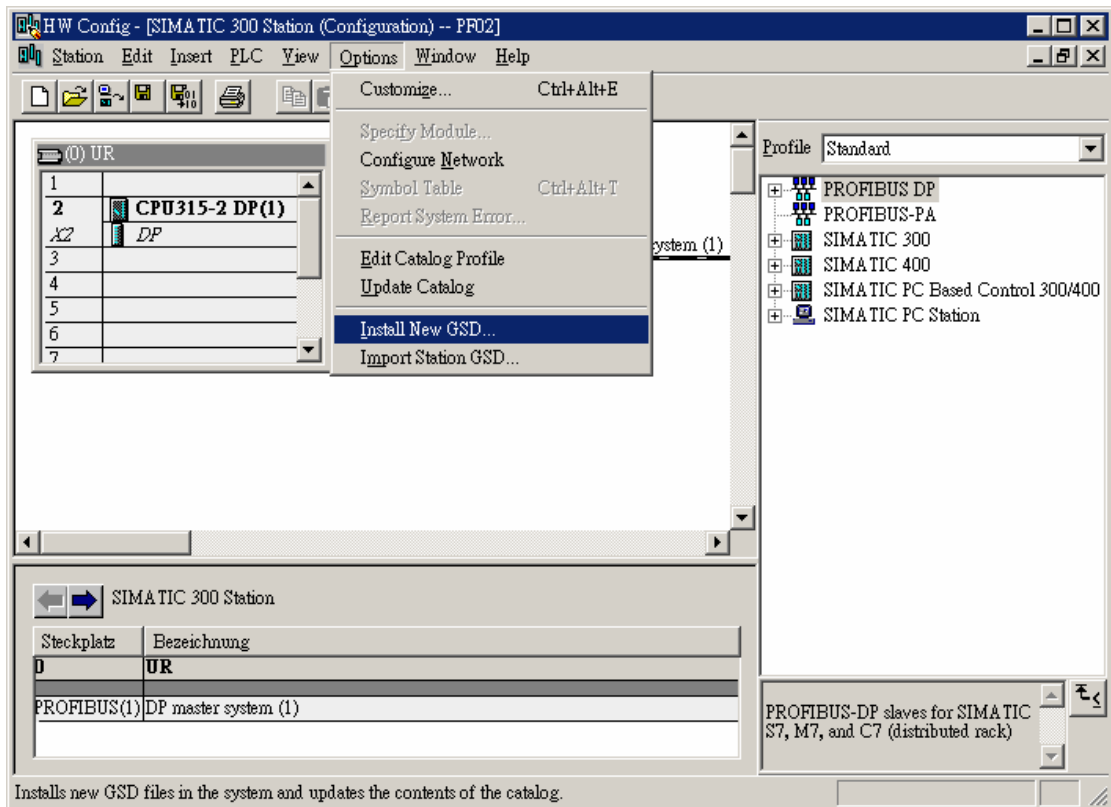

2. Find the path of the GSD file, select the GSD file to be installed and click on “Open” to create the GSD file needed.
3. Once the GSD file is created, you can find the relevant configuration parameters of DVPPF02-H2 in the right column.

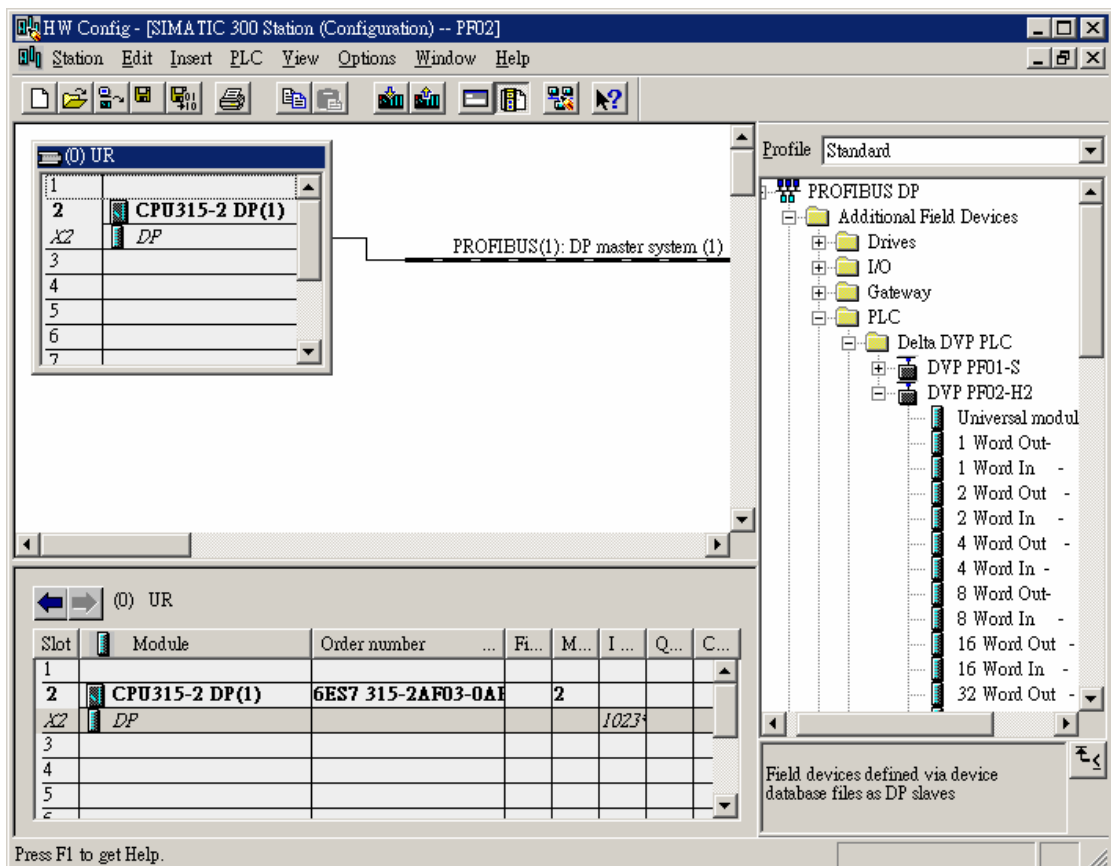

■ Creating DVPPF02-H2 slave and parameter configuration

1. Select PROFIBUS DP bus and double click on the DVPPF02-H2 icon in the right column. A new dialog box will appear.

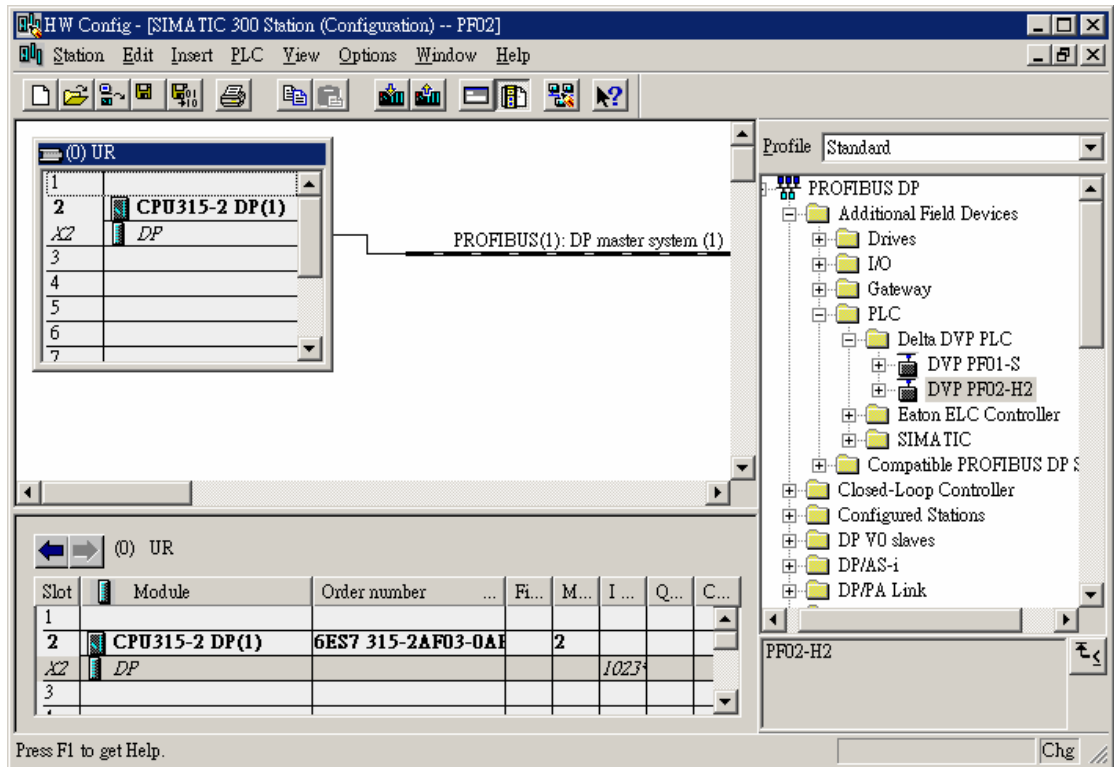

2. Select the address of DVPPF02-H2 slave (decimal). This address has to be the same as the address set by the address switch. Next, click on "OK".

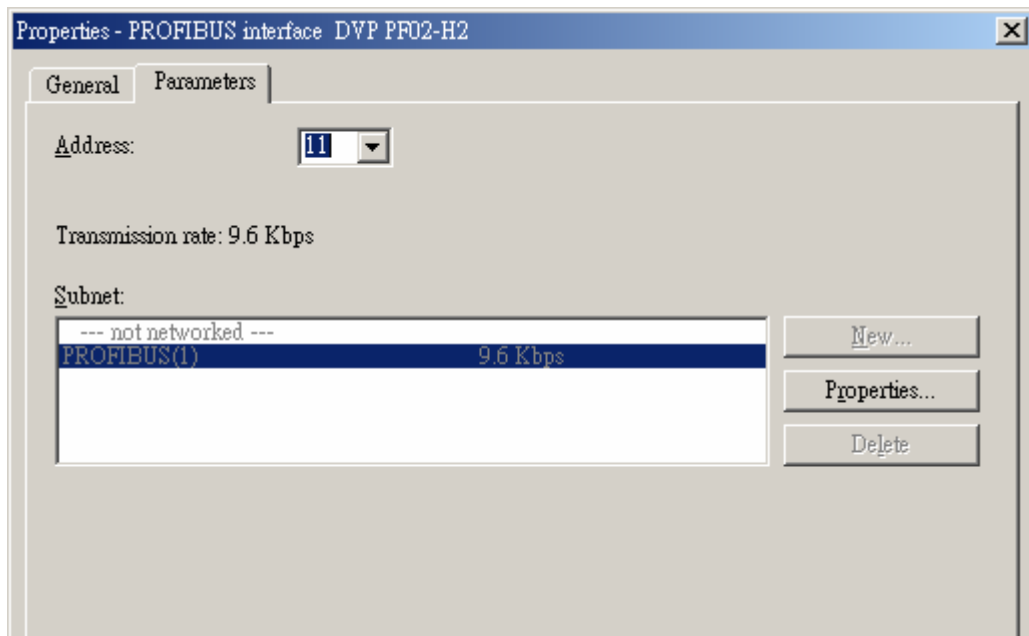

3. Add DVPPF02-H2 into PROFIBUS DP bus.

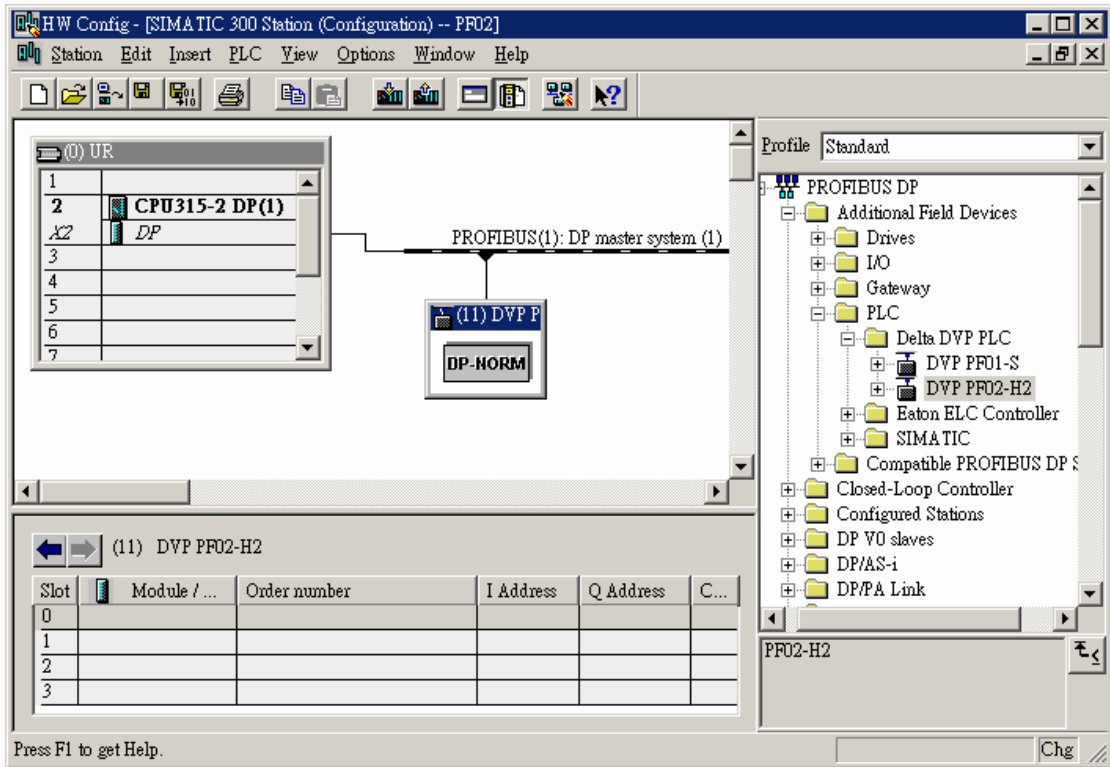

- Select "Slot 0" and double click on "2 Word Out" in the right column.

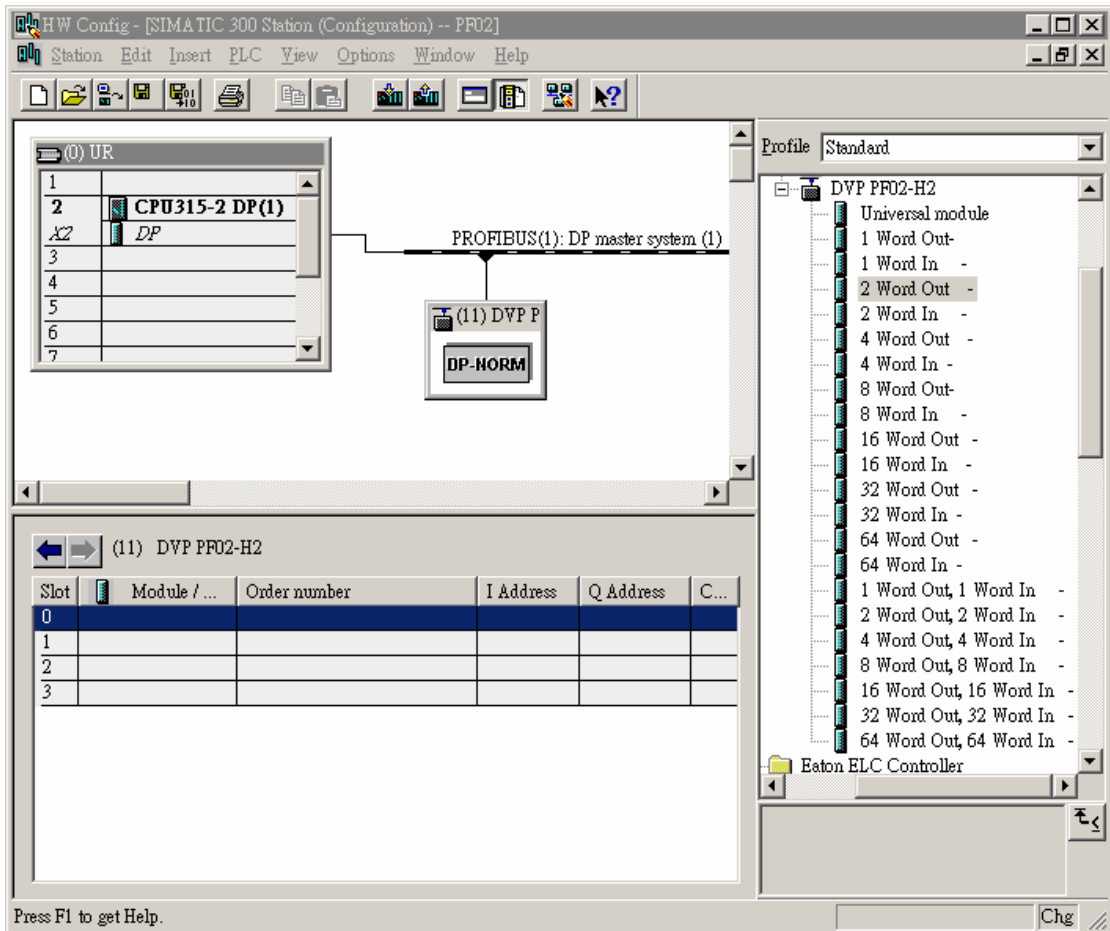

- Configure the parameter of "2 Word Out" to Slot 0.

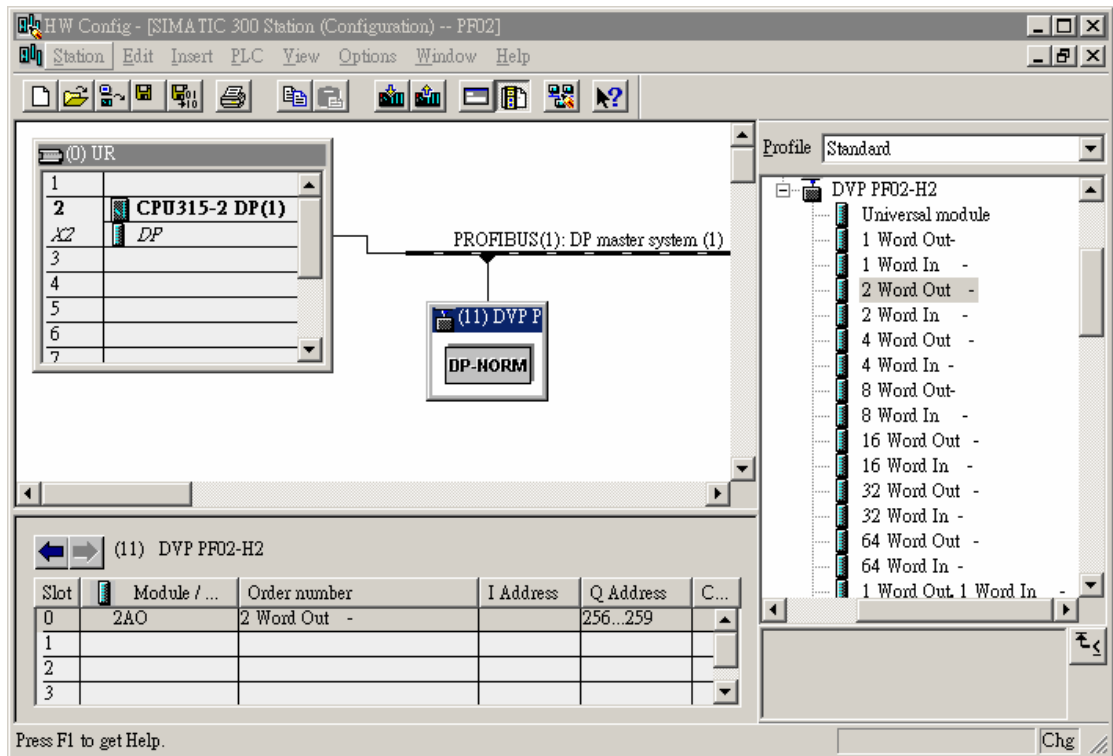

6. Configure parameters of other slots in the same way.

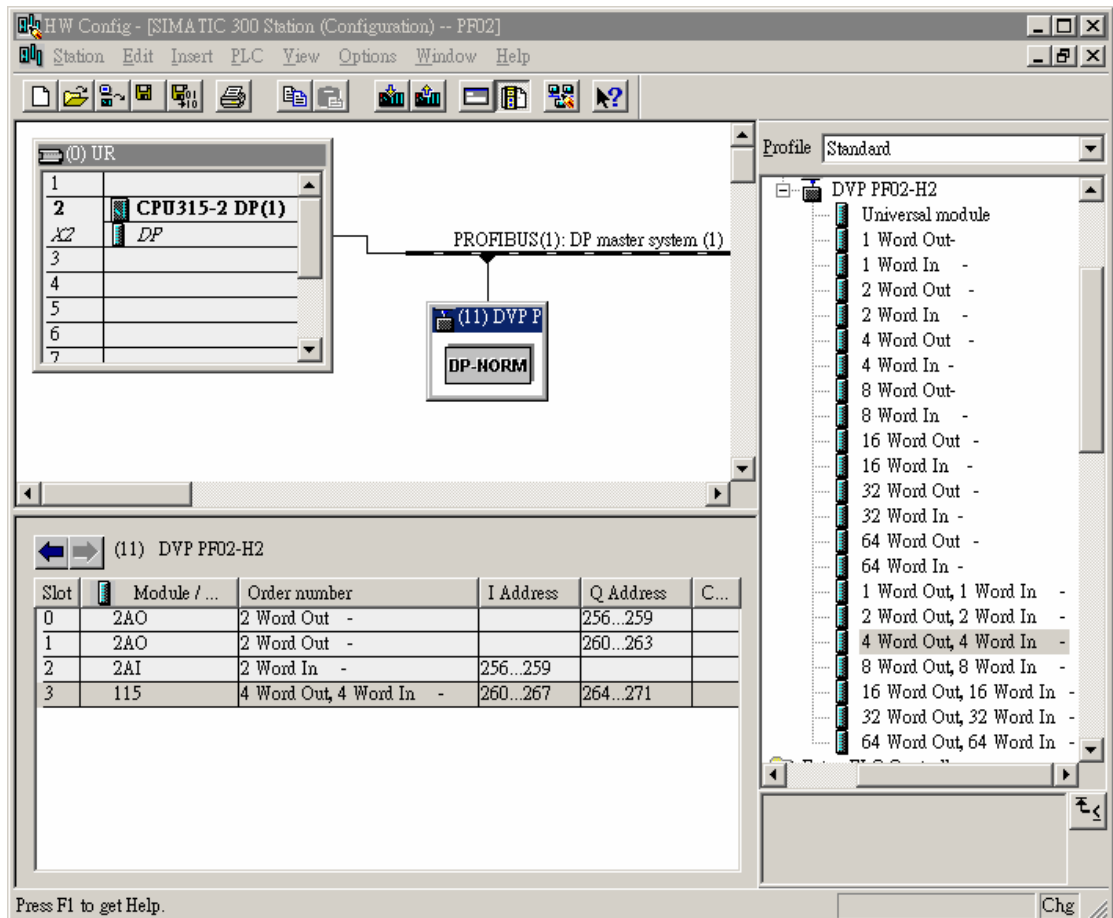

Note: DVPPF02-H2 is able to configure parameters in the 4 slots of the master. Configurable parameters in DVPPF02-H2 are in the column on the right hand side. You can configure different types of parameters in the 4 slots. The same type of parameters can be configured in different slots

(e.g. the configuration of slot 0, slot 1). The maximum length of total input data is 100 words (the sum of input length of 4 slots). The maximum length of total output data is 100 words (the sum of output length of 4 slots).

■ Downloading configured parameters

1. After the parameter is configured, click on  in the “HW Config” window, and you will see the dialog box as below. Click on “OK” and another dialog box will appear.

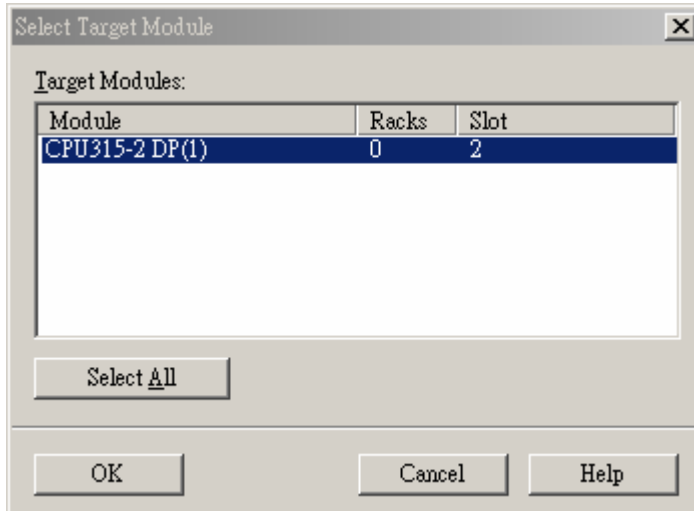

2. Click on “OK” to start to download the configured parameter.

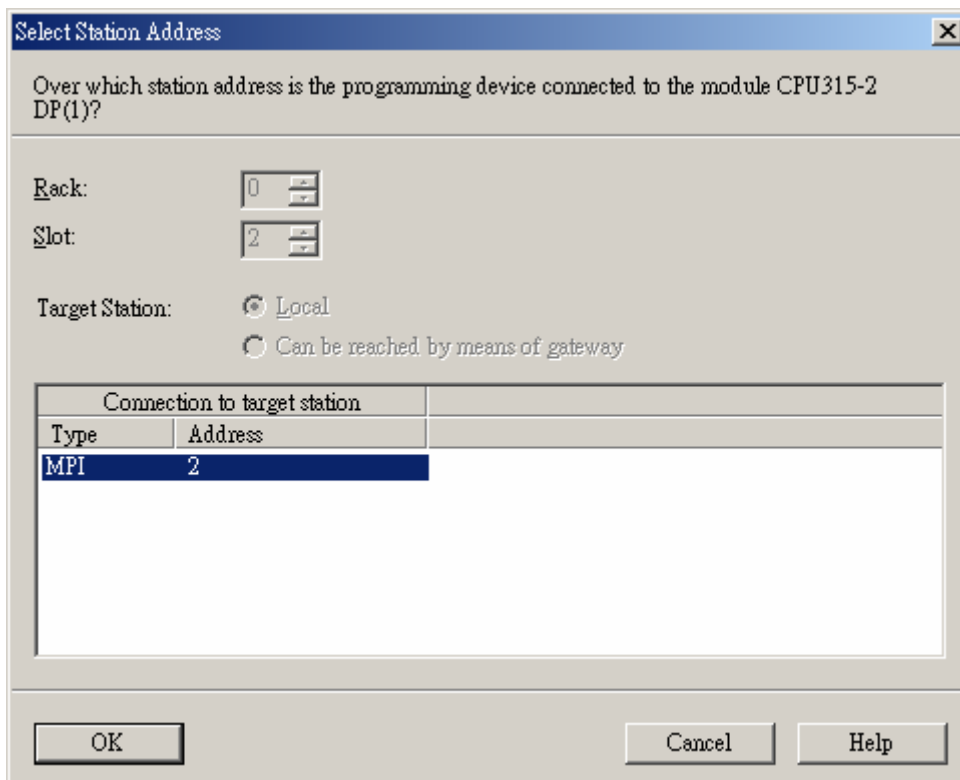

3. The parameter is being downloaded.

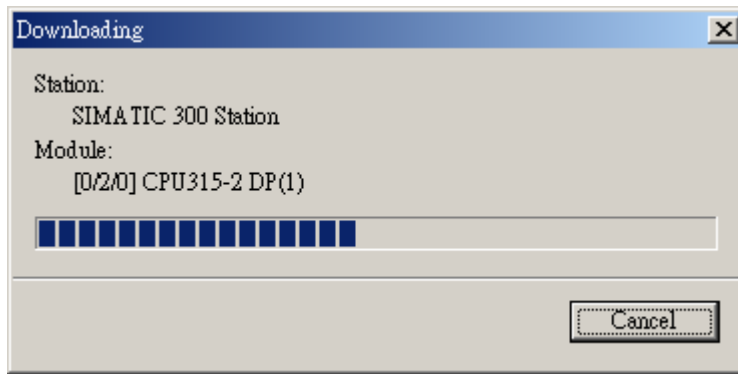

4. After the download is completed, the NET LED on DVPPF02-H2 will be constantly on in green.

◆ **Data mapping**

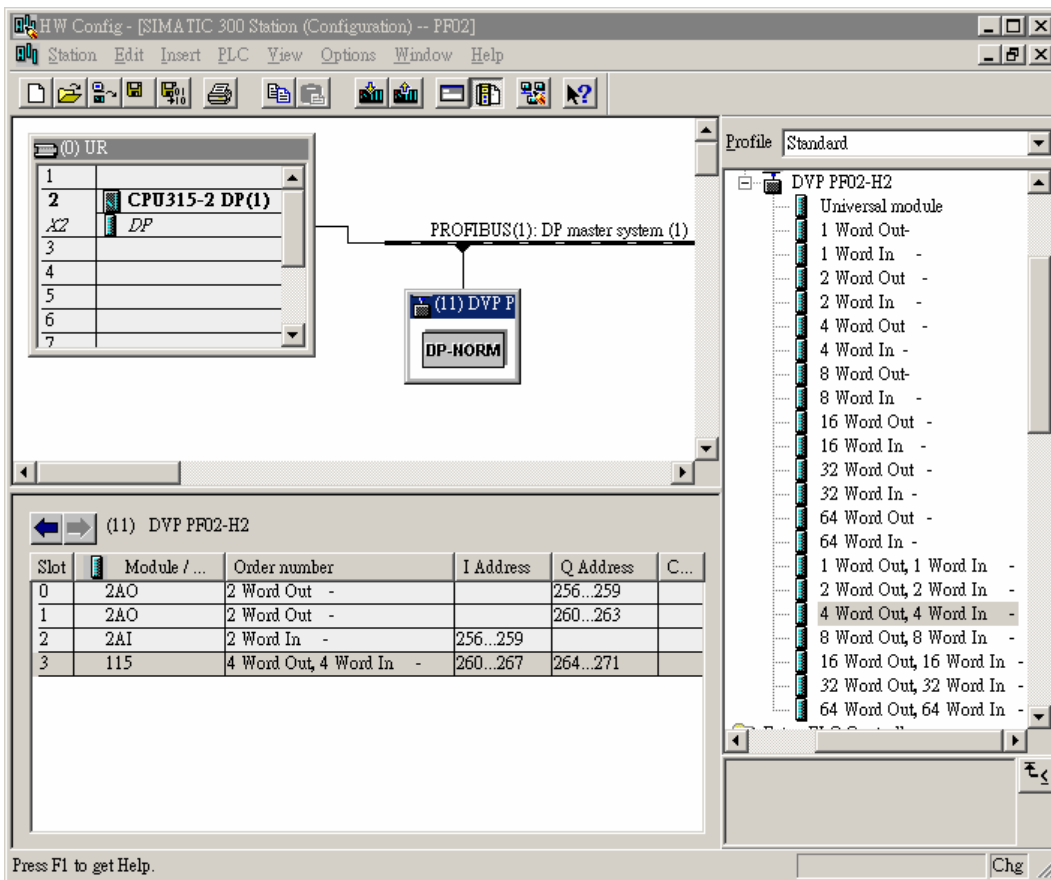

See the data mapping information in the table below under the parameter configuration as shown above:

Slot	External I/O word for S7-300	Data transmission direction in PROFIBUS DP network	Register in DVPPF02-H2
0	PQW256	➔	CR#103
	PQW258		CR#104
1	PQW260		CR#105
	PQW262		CR#106
3	PQW264		CR#107
	PQW266		CR#108
	PQW268		CR#109
	PQW270		CR#110

Slot	External I/O word for S7-300	Data transmission direction in PROFIBUS DP network	Register in DVPPF02-H2
2	PIW256	←	CR#3
	PIW258		CR#4
3	PIW260		CR#5
	PIW262		CR#6
	PIW264		CR#7
	PIW266		CR#8

About data mapping:

The I Address of the master (starting from the first address of slot 0 ~ slot 4) corresponds to CR from CR#3 of the slave. The Q Address (starting from the first address of slot 0 ~ slot 4) corresponds to CR from CR#103. The I/Q Address in every slot increases by 2, in which the I Address is indicated as PIW and Q Address as PQW. The CR corresponds to PIW and PQW increases by 1. According to the table above, the data in PQW256 ~ PQW270 are transmitted automatically to CR#103 ~ CR#110, and the data in CR#3 ~ CR#8 are transmitted automatically to PIW256 ~ PIW266 through PROFIBUS DP bus. The above mapping relation will be formed automatically after the parameter is configured.

◆ Program example

■ Program of slave

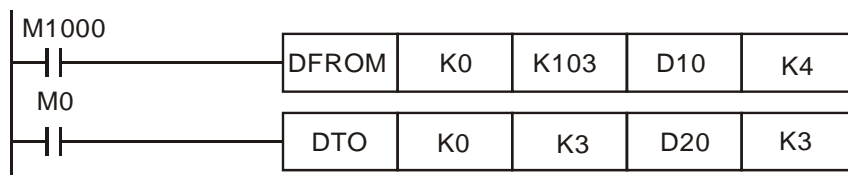

- When DVP-EH2 PLC MPU is running and M1000 is On, DVP-EH2 will move the 8 words of data transmitted from PROFIBUS DP master to CR#103 ~ CR#110 to D10 ~ D17 through PROFIBUS DP bus. When M0 = On, DVP-EH2 will write the contents in D20 ~ D25 into CR#3 ~ CR#8. DVPPF02-H2 will transmit these data to PROFIBUS DP master through PROFIBUS DP bus.
- PROFIBUS DP bus completes the data transmission between the master and DVPPF02-H2. DFROM/DTO instruction however completes the reading/writing of CR data in DVPPF02-H2 by DVP-EH2.
- Make sure you use DFROM/DTO instruction instead of FROM/TO instruction to deal with the CR data in DVPPF02-H2 by DVP-EH2.

See the table below for the data transmission information:

Slot	External I/O word for S7-300	Data transmission direction in PROFIBUS DP network	Register in DVPPF02-H2	DFROM/DTO operation	Register in DVP-EH2
0	PQW256	→	CR#103	→	D10
	PQW258		CR#104		D11
1	PQW260		CR#105		D12
	PQW262		CR#106		D13
3	PQW264		CR#107		D14

Slot	External I/O word for S7-300	Data transmission direction in PROFIBUS DP network	Register in DVPPF02-H2	DFROM/DTO operation	Register in DVP-EH2
	PQW266		CR#108		D15
	PQW268		CR#109		D16
	PQW270		CR#110		D17
2	PIW256	←	CR#3	← DTO (write)	D20
	PIW258		CR#4		D21
3	PIW260		CR#5		D22
	PIW262		CR#6		D23
	PIW264		CR#7		D24
	PIW266		CR#8		D25

MEMO