

1 2 3 4

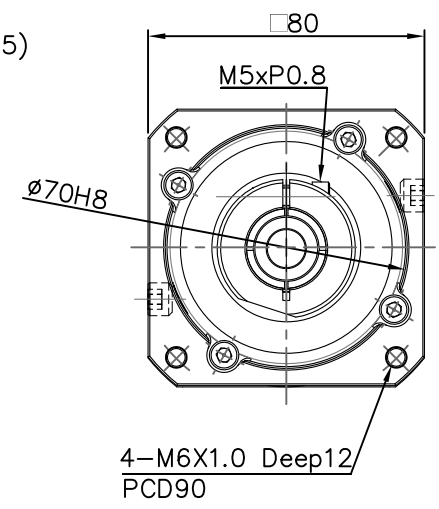
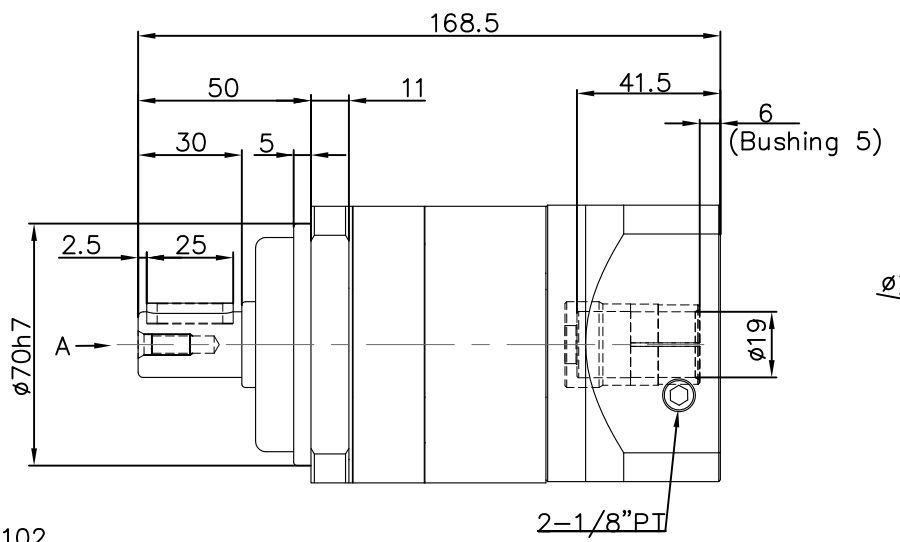
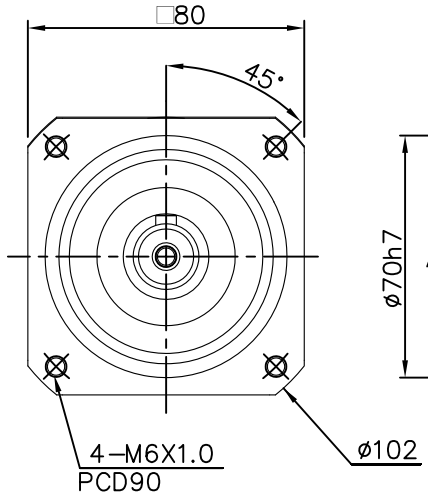
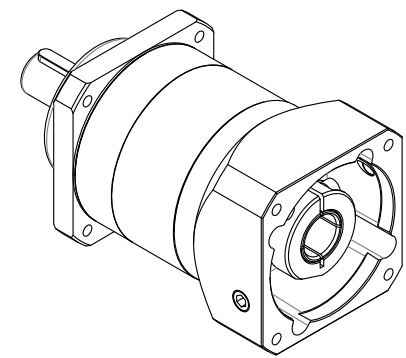
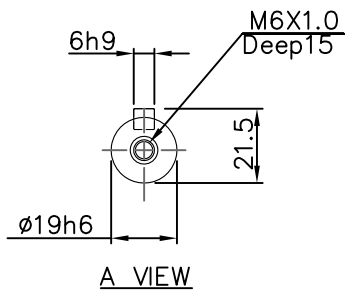

NOTES.

1. Match Motor Flange:  $\phi 70$
2. Output shaft have keyway, without keyway is optional.
3. Bushing is supplied to input bore  $\phi 6, \phi 6.35, \phi 8, \phi 9, \phi 10, \phi 11, \phi 12.7, \phi 14$  or  $\phi 16$ .

MODEL	段数 (Stage)	減速比 (Ratio)	背隙 (Arcmin)	匹配馬達出軸直徑&長度
PA080-A015CC1635	雙段	15	12	16 & 35
PA080-A020CC1635	雙段	20	12	16 & 35
PA080-A025CC1635	雙段	20	12	16 & 35
PA080-A030CC1635	雙段	30	12	16 & 35
PA080-A035CC1635	雙段	35	12	16 & 35
PA080-A040CC1635	雙段	40	12	16 & 35
PA080-A050CC1635	雙段	50	12	16 & 35
PA080-A070CC1635	雙段	70	12	16 & 35
PA080-A100CC1635	雙段	100	12	16 & 35

Ration Application	15~100
Power Application	750W

台達電子工業股份有限公司 DELTA ELECTRONICS, INC.		Drawn:	Design:
THESE DRAWINGS AND SPECIFICATIONS ARE THE PROPERTY OF DELTA ELECTRONICS, INC. AND SHALL NOT BE REPRODUCED OR USED AS THE BASIS FOR THE MANUFACTURE OR SELL OF APPARATUS OR DEVICES WITHOUT PERMISSION.		Description: <b>Planetary Gearhead Servo Box</b>	
DIMENSIONAL TOLERANCES ( ) HOLES : ±0.05 ANGLES : ±0.5° <30 : ±0.25 DECIMALS UP-100 : ±0.2 250-300 : ±0.4 UP-600 : ±1.5 >30-100 : ±0.35 X : ±0.3 100-150 : ±0.25 300-350 : ±0.45 600-900 : ±2.4 >100-300 : ±0.5 X.X : ±0.2 150-200 : ±0.3 350-400 : ±0.5 900-OVER : ±3.1 ABOVE 300 : ±0.8 X,XX : ±0.1 200-250 : ±0.35		Part No. _____ REV. _____	SCALE _____ SHEET _____ OF _____ ISSUE DATE: _____
A3 SIZE		X0	

1 2 3 4