



Industrial Automation Headquarters

Delta Electronics, Inc.
Taoyuan Technology Center
No.18, Xinglong Rd., Taoyuan City,
Taoyuan County 33068, Taiwan
TEL: 886-3-362-6301 / FAX: 886-3-371-6301

Asia

Delta Electronics (Jiangsu) Ltd.
Wujiang Plant 3
1688 Jiangxing East Road,
Wujiang Economic Development Zone
Wujiang City, Jiang Su Province,
People's Republic of China (Post code: 215200)
TEL: 86-512-6340-3008 / FAX: 86-769-6340-7290

Delta Greentech (China) Co., Ltd.
238 Min-Xia Road, Pudong District,
Shanghai, P.R.C.
Post code : 201209
TEL: 86-21-58635678 / FAX: 86-21-58630003

Delta Electronics (Japan), Inc.
Tokyo Office
2-1-14 Minato-ku Shibadaimon,
Tokyo 105-0012, Japan
TEL: 81-3-5733-1111 / FAX: 81-3-5733-1211

Delta Electronics (Korea), Inc.
1511, Byucksan Digital Valley 6-cha, Gasan-dong,
Geumcheon-gu, Seoul, Korea, 153-704
TEL: 82-2-515-5303 / FAX: 82-2-515-5302

Delta Electronics Int'l (S) Pte Ltd
4 Kaki Bukit Ave 1, #05-05, Singapore 417939
TEL: 65-6747-5155 / FAX: 65-6744-9228

Delta Electronics (India) Pvt. Ltd.
Plot No 43 Sector 35, HSIIDC
Gurgaon, PIN 122001, Haryana, India
TEL : 91-124-4874900 / FAX : 91-124-4874945

Americas

Delta Products Corporation (USA)
Raleigh Office
P.O. Box 12173, 5101 Davis Drive,
Research Triangle Park, NC 27709, U.S.A.
TEL: 1-919-767-3800 / FAX: 1-919-767-8080

Delta Greentech (Brasil) S.A
Sao Paulo Office
Rua Itapeva, 26 - 3º andar Edificio Itapeva One-Bela Vista
01332-000-São Paulo-SP-Brazil
TEL: +55 11 3568-3855 / FAX: +55 11 3568-3865

Europe

Deltronics (The Netherlands) B.V.
Eindhoven Office
De Witbogt 15, 5652 AG Eindhoven, The Netherlands
TEL: 31-40-2592850 / FAX: 31-40-2592851

*We reserve the right to change the information in this catalogue without prior notice.

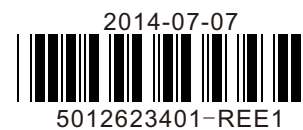

REG Series User Manual



Delta Power Regenerative Unit

REG2000 Series User Manual



www.delta.com.tw/ia



Preface

Please read prior to installation for safety.



- ☑ Ensure the power is OFF before wiring or installing the Power Regenerative Unit.
- ☑ After the AC power is turned off, please do not touch the internal circuits and components until the POWER indicator on the unit (below the digital controller) turns off, as the Power Regenerative Unit will still be charged with a high-voltage current and will be very dangerous.
- ☑ The components on the internal circuit board of the Power Regenerative Unit are susceptible to damage from electrostatic discharge. Please do not touch the circuit board with bare hands before proper antistatic measures are taken. Unauthorized modification of components or circuits within the Power Regenerative Unit is forbidden.
- ☑ The Power Regenerative Unit Ⓢ must be properly grounded. The 230V series uses Type 3 grounding; the 460V series uses special grounding.
- ☑ The Power Regenerative Unit and its components should be installed away from heat sources and flammable objects.



- ☑ The voltage rating of the power system onto which the Power Regenerative Unit is installed must not be higher than 240V for the 230V series (480V for the 460V series), and the current must not be greater than 5000A RMS (10000A RMS for models of 40HP (30kW) or more).
- ☑ Only a qualified professional electrician shall install, wire, repair and maintain the Power Regenerative Unit.
- ☑ Even when the Power Regenerative Unit is in standby mode, its main circuit terminals may still carry dangerously high voltage.
- ☑ If unopened and unused for more than 3 months, the ambient storage temperature must not be higher than 30°C. This is due to concerns that the electrolytic capacitors are likely to deteriorate if stored with no power supply at high ambient temperatures. Please do not leave it in a state without power supply for more than one year.
- ☑ Notes for the disinfection and disinfestation of packaging materials for transportation and installation (including wooden crates, planks, cardboard boxes, etc.):
 1. When disinfecting or disinfesting packaging materials, such as crates or cartons, please do not fumigate to avoid damaging internal components.
 2. Please use alternative environmental disinfection or disinfestation methods.
 3. Permitted high temperature methods: Simply leave the packaging materials at a temperature of over 56°C for 30 minutes or more.
 4. Fumigation is forbidden, any damage caused by fumigation will not be covered by warranty.



- The pictures and corresponding descriptions in this manual will feature the product with the outer casing or safety shields removed or disassembled to better explain the product in detail. As for the actual product in operation, please be sure to

correctly install the outer casing and wirings in accordance with the rules and regulations, and operate the product following the instructions in the manual to ensure your safety.

- The illustrations in the manual may slightly differ from the actual product for demonstration purposes, but will not affect the rights and interests of the customer.
- When product documentation is updated or modified, the latest edition can be downloaded from the industrial automation product page on the Delta Electronics website. (<http://www.delta.com.tw/industrialautomation/>)

Table of Contents

01 Product Overview	1-1
02 Checking & Recommendations.....	2-1
03 Specifications.....	3-1
04 Wiring.....	4-1
4-1 Wiring Diagram.....	4-2
4-2 Main Circuit Terminals.....	4-4
4-3 Control Circuit Terminals.....	4-9
4-4 Display Panel Indicators.....	4-13
05 Optional Accessories.....	5-1
5-1 Digital Controller.....	5-2
5-2 USB/RS485 Transmission Converter IFD6530.....	5-4
5-3 Fuse.....	5-8
06 List of Parameters.....	6-1
07 Detailed Description of Parameters	7-1
08 Warnings and Fault Display Codes.....	8-1
09 Usage Recommendations and Troubleshooting	9-1
10 Power Regenerative Unit Selection.....	10-1

Supported Version Control BD V1.02;

01 Product Overview

Users should follow the steps below before using the product to ensure safety during use.

- 1) After opening the packaging, first check the product has not been damaged during shipment. Inspect and ensure that the nameplate labels on the product match the ones on the box.
- 2) Make sure the wiring is suitable for the voltage range of the Power Regenerative Unit. Please follow the instructions in the installation manual when installing the Power Regenerative Unit.
- 3) When wiring the Power Regenerative Unit, please be aware of the wiring positions of the main circuit terminals "R/L1, S/L2, T/L3, DC+, DC-", and make sure the terminals are wired correctly to prevent any damage.

Nameplate Description

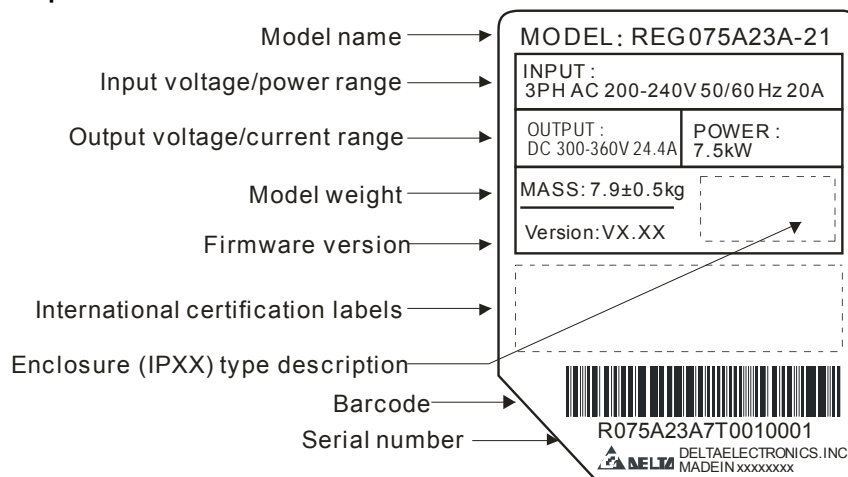

Model Number Description

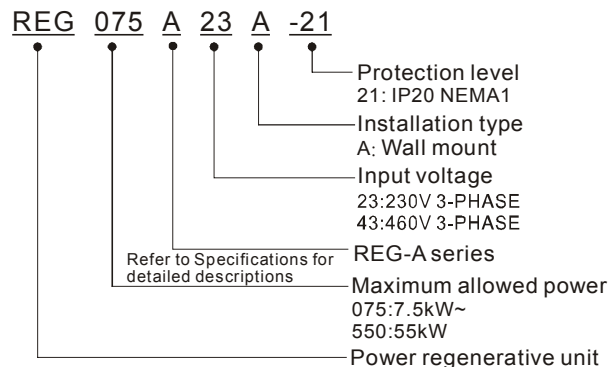

Serial Number Description

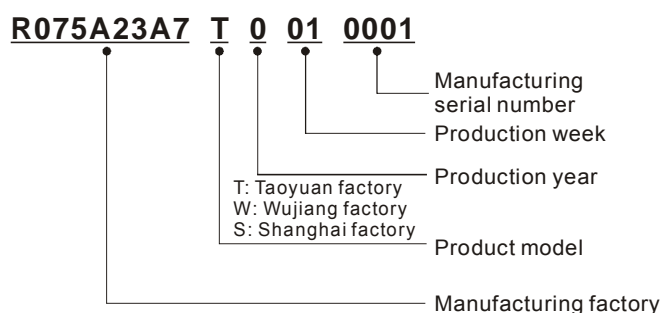

Operation Principle

In a variable-frequency drive system, due to the high inertia in a drive system, such as centrifuges and washing machines, or applications requiring fast braking, such as machine tool spindles, the motor will be in a power generating state. In other words, because the rotor is being dragged by external forces, the actual motor speed exceeds the inverter-controlled synchronous speed, quickly feeding the energy generated by the motor back to the DC bus, resulting in a rapid rise in the DC bus voltage, thereby endangering the inverter. Therefore, this excess energy must be quickly consumed, to keep the DC bus voltage within a safe range, otherwise the inverter will either malfunction or enter overvoltage protection mode. The traditional method is to convert the excess energy into heat by using a brake resistor. This method has the advantages of simpler wiring and lower total cost, but also has disadvantages of a large brake resistor, requiring additional cooling devices, a limited braking capability, and inefficient use of the energy. On the other hand, the Power Regenerative Unit (REG2000) can convert the power generated by the motor into electric energy, and then return it to the electrical grid for other electrical applications, conserving energy. After the installation the Power Regenerative Unit, the motor's braking capability can also be increased.

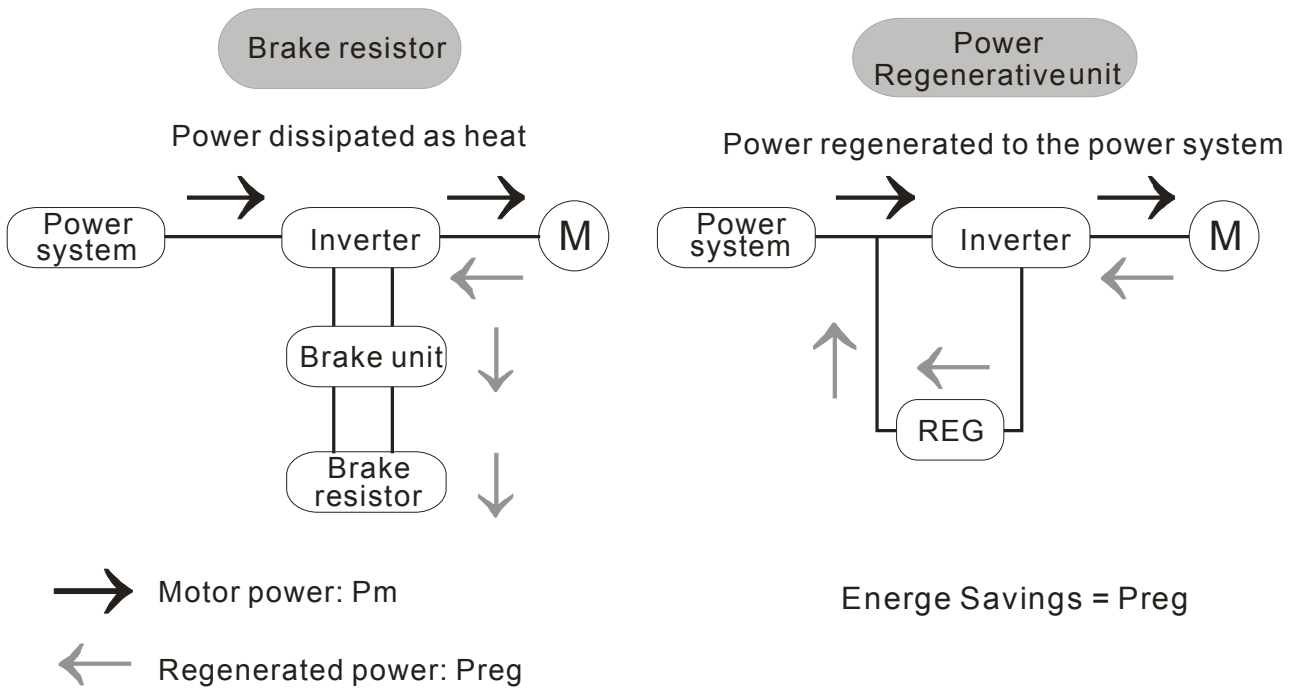

RFI Short-Circuit Cable Description

RFI: The Power Regenerative Unit generates electrical noise, resulting in frequency interference on the AC power cord (Radio Frequency Interference)

Frame A~C Screw torque: 6~8kg-cm(5.2-6.9 lb -in.)

After loosening the screw, remove the MOV-PLATE (as shown in the diagram below). Make sure to tighten the screw back after removing the MOV-PLATE.

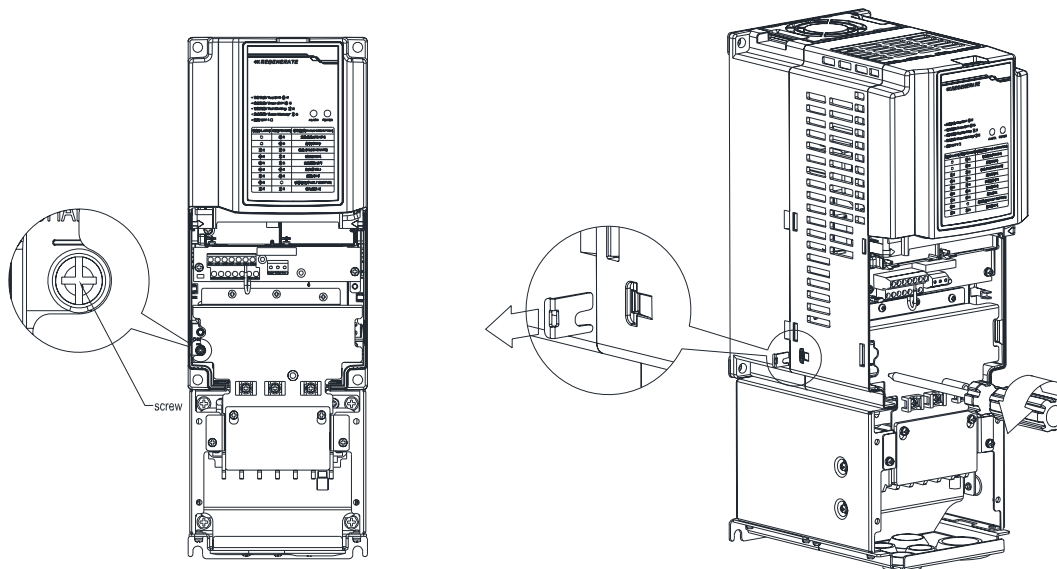

Isolating main power from ground:

When the power distribution system of the Power Regenerative Unit is a floating ground system (IT) or an asymmetric ground system (TN), the RFI short short-circuit cable must be cut off. Cutting off the short-circuit cable cuts off the internal RFI capacitor (filter capacitor) between the system's frame and the central circuits to avoid damaging the central circuits and (according to IEC 61800-3) reduce the ground leakage current.

Important points regarding ground connection

- ☑ To ensure the safety of personnel, proper operation, and to reduce electromagnetic radiation, the Power Regenerative Unit must be properly grounded during installation.
- ☑ The diameter of the cables must meet the size specified by safety regulations.
- ☑ The shielded cable must be connected to the ground of the Power Regenerative Unit to meet safety regulations.
- ☑ The shielded cable can only be used as the ground for equipment when the aforementioned points are met.
- ☑ When installing multiple sets of Power Regenerative Units, do not connect the grounds of the Power Regenerative Units in series. As shown below

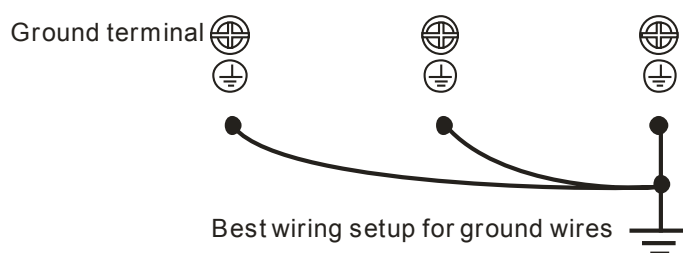

Pay particular attention to the following points:

- ☑ After turning on the main power, do not cut the RFI short-circuit cable while the power is on.
- ☑ Make sure the main power is turned off before cutting the RFI short-circuit cable.
- ☑ Cutting the RFI short-circuit cable will also cut off the conductivity of the capacitor. Gap discharge may occur once the transient voltage exceeds 1000V.

If the RFI short-circuit cable is cut, there will no longer be reliable electrical isolation. In other words, all controlled input and outputs can only be seen as low-voltage terminals with basic electrical isolation. Also, when the internal RFI capacitor is cut off, the Power Regenerative Unit will no longer be electromagnetic compatible.

- ☑ The RFI short-circuit cable may not be cut off if the main power is a grounded power system.
- ☑ The RFI short-circuit cable may not be cut off while conducting high voltage tests. When conducting a high voltage test to the entire facility, the main power and the motor must be disconnected if leakage current is too high.

Floating Ground System(IT Systems)

A floating ground system is also called IT system, ungrounded system, or high impedance/resistance (greater than 30Ω) grounding system.

- ☑ Disconnect the ground cable from the internal EMC filter.
- ☑ In situations where EMC is required, check whether there is excess electromagnetic radiation affecting nearby low-voltage circuits. In some situations, the adapter and cable naturally provide enough suppression. If in doubt, install an extra electrostatic shielded cable on the power supply side between the main circuit and the control terminals to increase security.
- ☑ Do not install an external RFI/EMC filter, the EMC filter will pass through a filter capacitor, thus connecting power input to ground. This is very dangerous and can easily damage the Power Regenerative Unit.

Asymmetric Ground System(Corner Grounded TN Systems)

Caution: Do not cut the RFI short-circuit cable while the input terminal of the Power Regenerative Unit carries power.

In the following four situations, the RFI short-circuit cable must be cut off. This is to prevent the system from grounding through the RFI capacitor, damaging the Power Regenerative Unit.

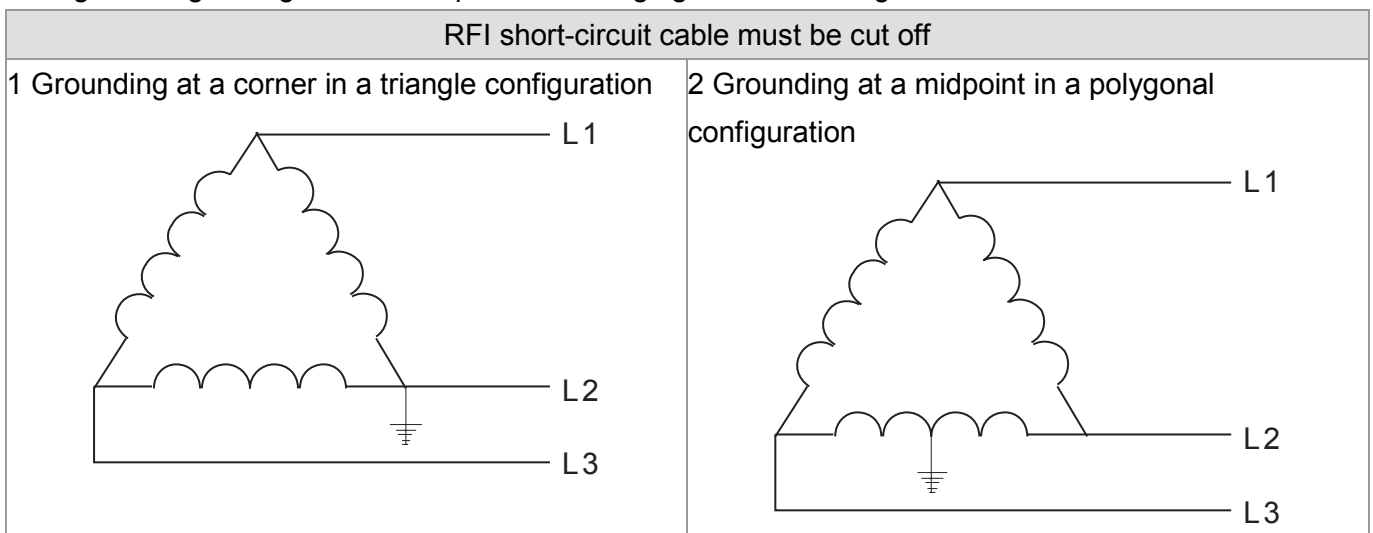

3 Grounding at one end in a single-phase configuration

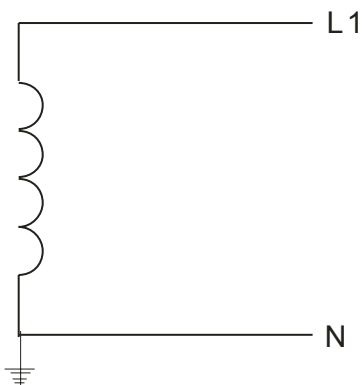

4 No stable neutral grounding in a three-phase autotransformer configuration

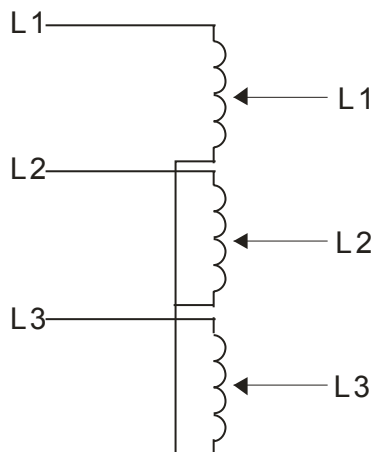

RFI short-circuit can be used

Internal grounding through RFI capacitor, which reduces electromagnetic radiation. In a situation with higher requirements for electromagnetic compatibility, and using a symmetrical grounding power system, an EMC filter can be installed. As a reference, the diagram on the right is a symmetrical grounding power system.

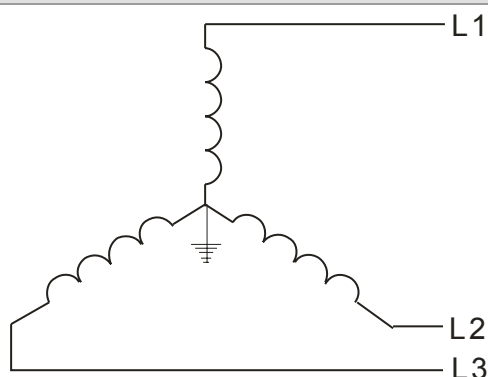

Dimensions

Frame A

REG075A23A-21; REG110A23A-21; REG075A43A-21; REG110A43A-21; REG150A43A-21;

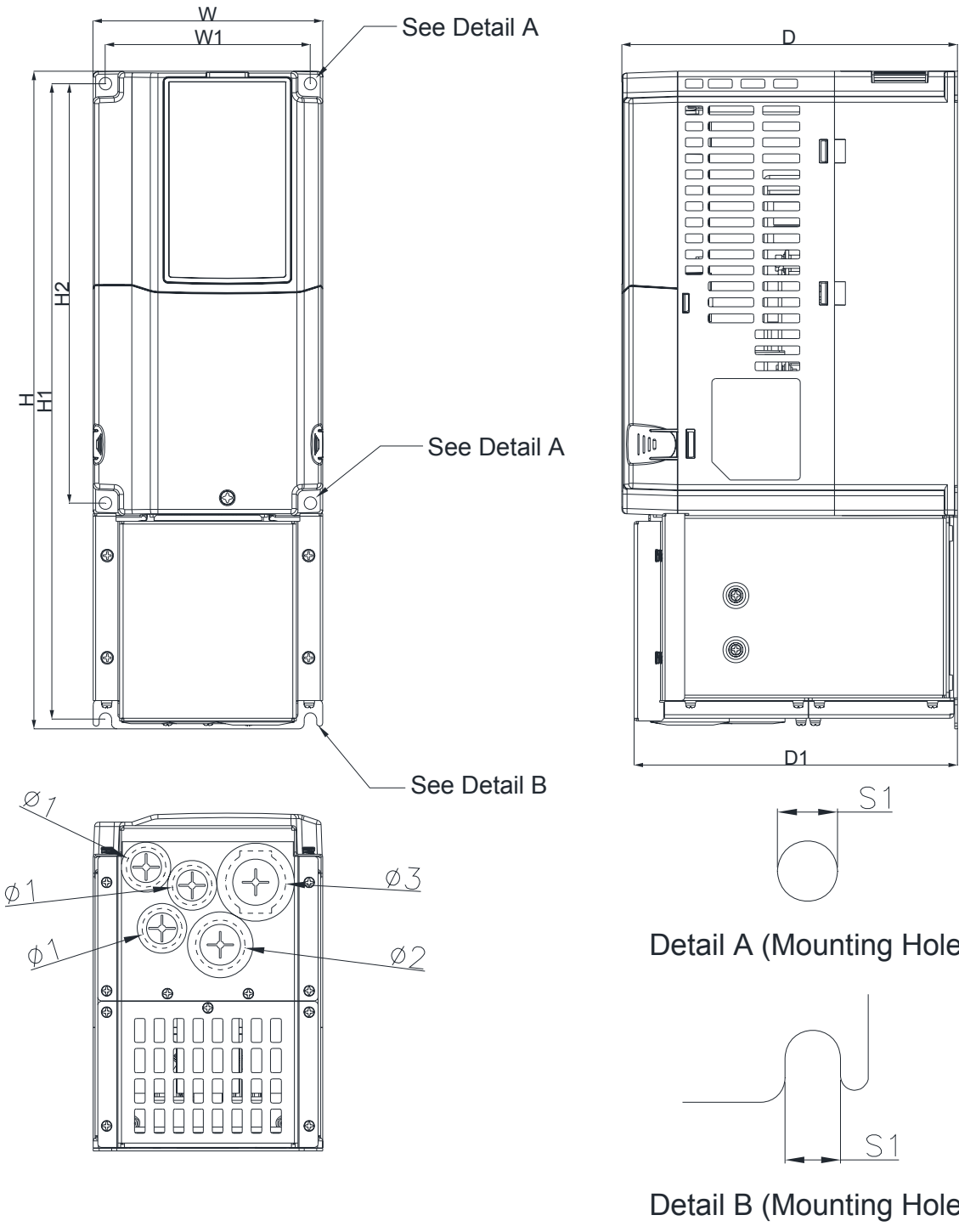

Unit: mm [inch]

Frame	W	H	D	W1	H1	H2	D1	S1	$\Phi 1$	$\Phi 2$	$\Phi 3$
A1	130.0 [5.12]	370.0 [14.56]	190.0 [7.48]	116.0 [4.57]	357.5 [14.07]	236.0 [9.29]	183.0 [7.20]	7.0 [0.28]	22.2 [0.87]	28.0 [1.10]	34.0 [1.34]

Frame B

REG150A23A-21; REG185A23A-21; REG220A23A-21; REG185A43A-21; REG220A43A-21;
REG300A43A-21;

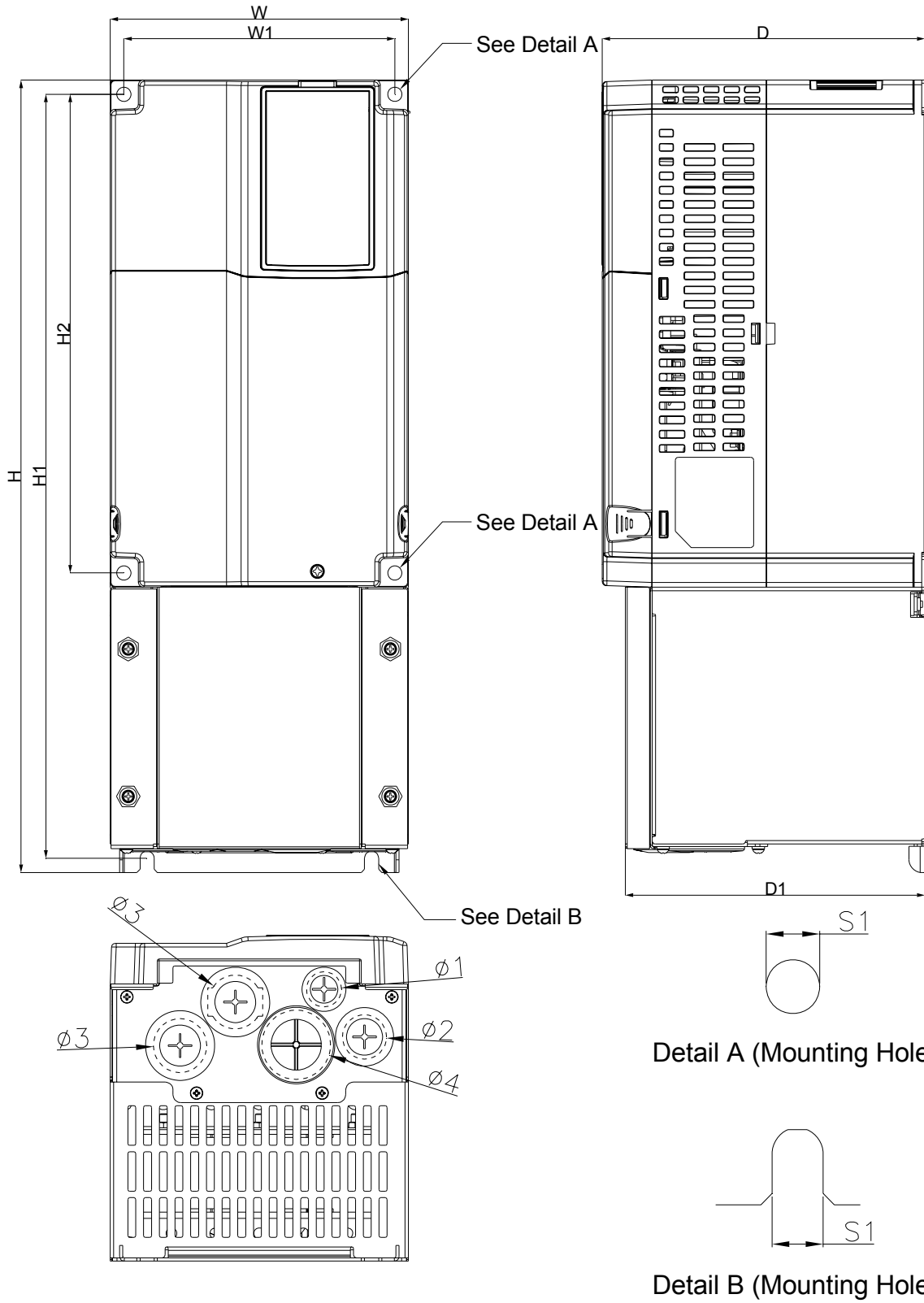

Unit: mm [inch]

Frame	W	H	D	W1	H1	H2	D1	S1	Φ1	Φ2	Φ3	Φ4
B1	190.0 [7.48]	500.0 [19.68]	205.0 [8.09]	172.5 [6.79]	482.0 [18.98]	302.0 [11.89]	190.5 [7.50]	9.0 [0.35]	22.2 [0.87]	28.0 [1.10]	34.0 [1.34]	43.8 [1.72]

Frame C

REG300A23A-21; REG370A23A-21; REG370A43A-21; REG450A43A-21; REG550A43A-21;

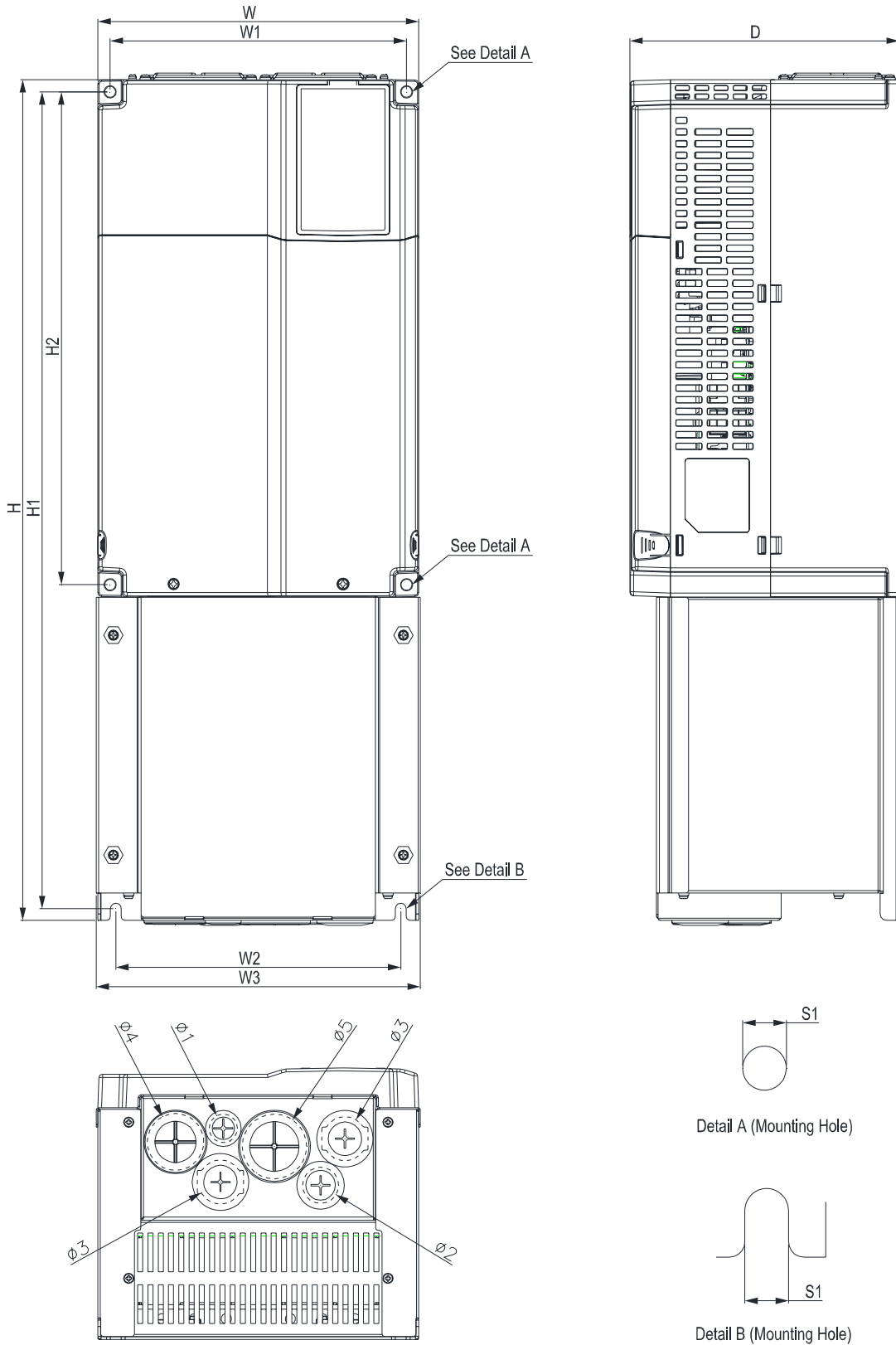

Unit: mm [inch]

Frame	W	H	D	W1	W2	W3	H1	H2	S1	Φ1	Φ2	Φ3	Φ4	Φ5
C1	250.0 [9.84]	650.0 [25.59]	210.0 [8.27]	231.0 [9.09]	220.0 [8.74]	252.5 [9.94]	631.5 [24.86]	381.0 [15.00]	8.5 [0.33]	22.2 [0.87]	28.0 [1.10]	34.0 [1.34]	44.0 [1.73]	50.1 [1.97]

02 Checking & Recommendations

Setup Distances & Wiring Description

 **NOTE**

- ☑ Please make sure that this product is installed upright.
- ☑ Do not allow foreign materials such as fibers, paper, wood chips/dust, or scrap metal to enter the power regenerative unit or adhere to the cooling fan.
- ☑ The unit should be installed to a metallic or other nonflammable control panel, otherwise it may cause a fire.
- ☑ The power regenerative unit should be installed in an environment that complies to pollution level 2 with clean circulating air. Clean circulating air is defined as air without polluting substances or electronically contaminated dust.

The following diagrams are for demonstration purposes only, and may differ from the actual product, in which case please refer to the actual product

 (Blue arrow) Air intake  (Red arrow) Air outflow

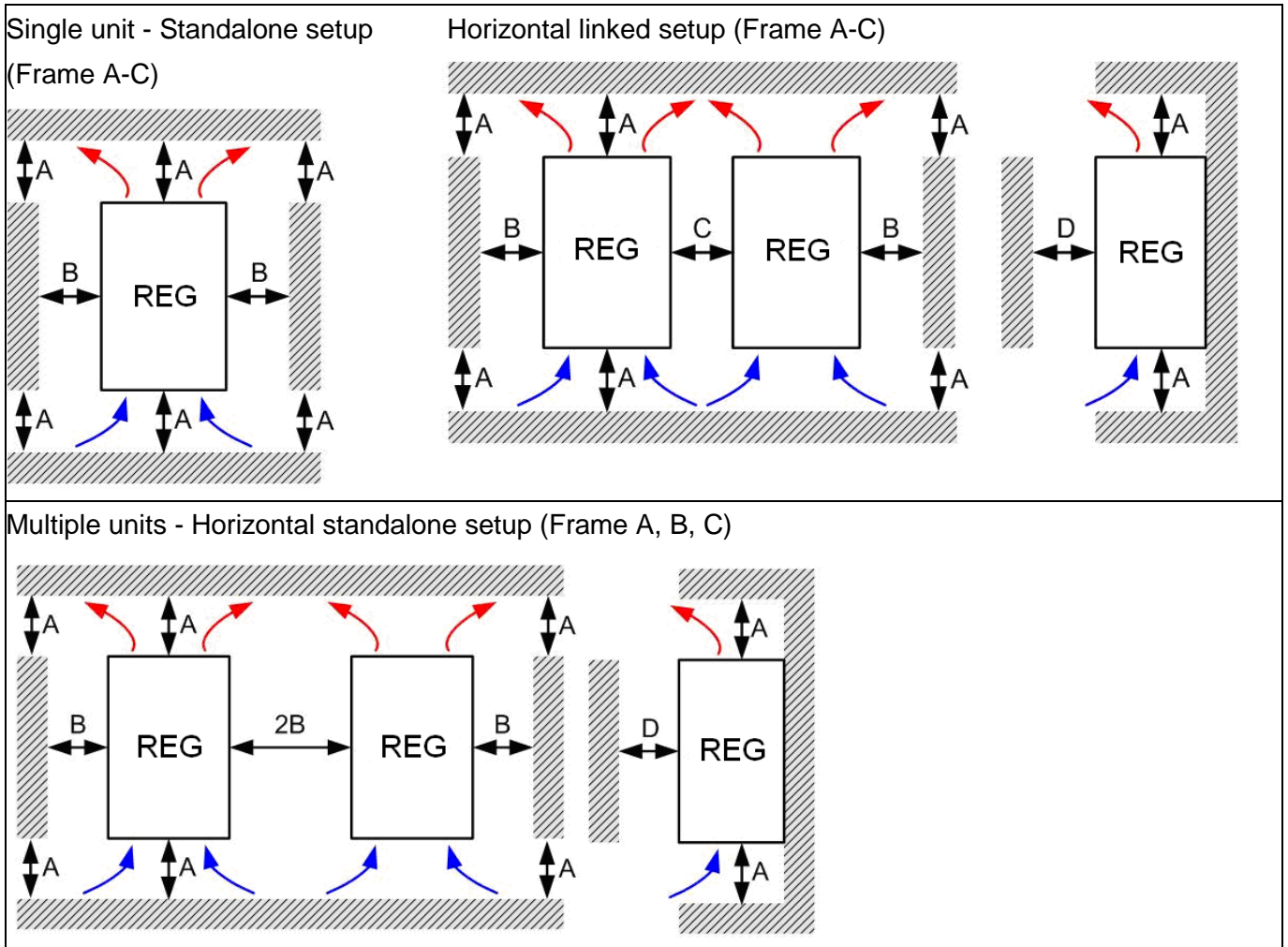

Multiple units - Vertical linked setup (Frame A, B, C)

Ta: Frame A~C

When setting up multiple units in a vertical standalone setup, dividers should be installed between the levels, and the dimensions of the dividers should be determined on the principle that the temperature at the intake fans should be lower than the operating temperature.

(As shown in the diagrams below) Operating temperature is defined as the temperature measured 50mm in front of the fan inlet.

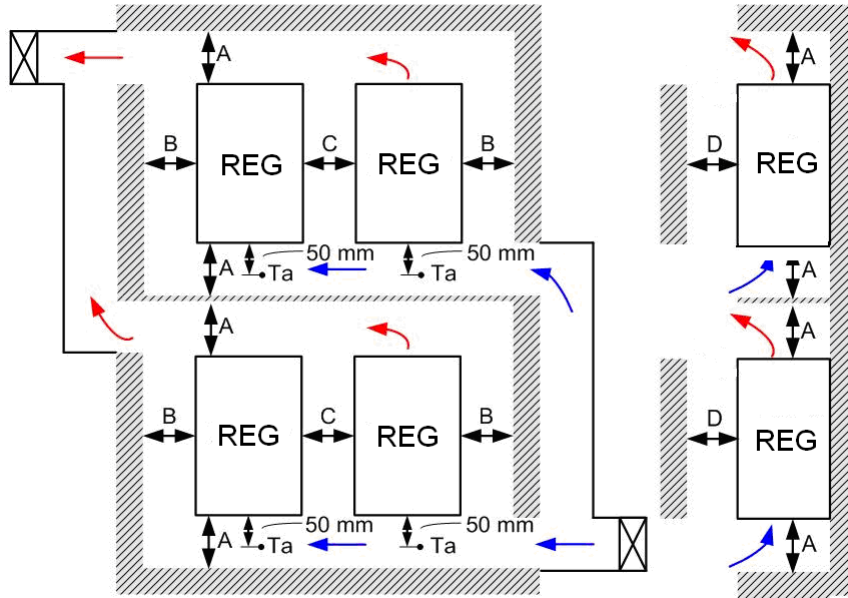

Distances

Frame	A (mm)	B (mm)	C (mm)	D (mm)
A~C	60	30	10	0

Frame A	REG075A23A-21; REG110A23A-21; REG075A43A-21; REG110A43A-21; REG150A43A-21;
Frame B	REG150A23A-21; REG185A23A-21; REG220A23A-21; REG185A43A-21; REG220A43A-21; REG300A43A-21;
Frame C	REG300A23A-21; REG370A23A-21; REG370A43A-21; REG450A43A-21; REG550A43A-21;

NOTE

A-D above are all required minimum distances, any distances under these values will affect the fan's functions.

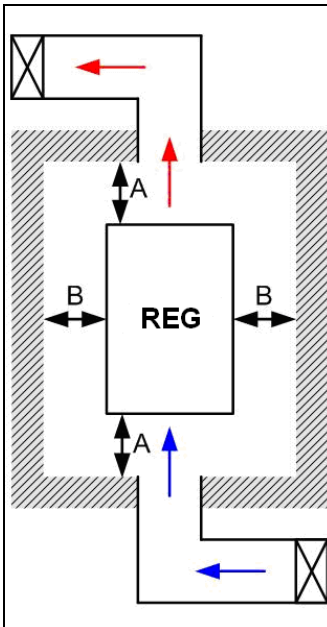

NOTE

- ※ (As shown in the diagram on the left) The specified distances are only applicable in open spaces. If the units are being installed in a closed space (such as distribution channel or chassis), in addition to keeping the same distances as in an open space, please also install ventilation or air conditioning systems to keep the ambient temperature under the operating temperature.
- ※ The table shows the required air flow rate for each model when installing single units in a closed space. For multiple units, the required air flow rate must be multiplied by the number of units installed.
- ※ Please refer to Air flow rate for cooling in the attached table when selecting and designing ventilation systems (Air flow rate for cooling).
- ※ For the design of air conditioning systems, please refer to Power Dissipation in the attached table. (Power Dissipation).

Air flow rate for cooling						
Model No.	Flow Rate (cfm)			Flow Rate (m ³ /hr)		
	External	Internal	Total	External	Internal	Total
REG075A23A-21	44	-	44	75	-	75
REG110A23A-21	44	-	44	75	-	75
REG150A23A-21	92	-	92	155	-	155
REG185A23A-21	92	-	92	155	-	155
REG220A23A-21	92	-	92	155	-	155
REG300A23A-21	121	-	121	206	-	206
REG370A23A-21	118	15	133	201	25	226
REG075A43A-21	44	-	44	75	-	75
REG110A43A-21	44	-	44	75	-	75
REG150A43A-21	44	-	44	75	-	75
REG185A43A-21	92	-	92	155	-	155
REG220A43A-21	92	-	92	155	-	155
REG300A43A-21	92	-	92	155	-	155
REG370A43A-21	121	-	121	206	-	206
REG450A43A-21	118	15	133	201	25	226
REG550A43A-21	118	15	133	201	25	226

- ※ The table shows the required air flow rate for each model when installing single units in a closed space.
- ※ For multiple units, multiply the required air flow rate for single-unit installation by the number of units installed.

Power dissipation of REG			
Model No.	Loss External (Heat sink)	Internal	Total
REG075A23A-21	127	86	213
REG110A23A-21	203	121	324
REG150A23A-21	219	161	380
REG185A23A-21	255	184	439
REG220A23A-21	336	216	552
REG300A23A-21	434	186	620
REG370A23A-21	678	220	898
REG075A43A-21	128	76	204
REG110A43A-21	198	93	291
REG150A43A-21	240	122	362
REG185A43A-21	291	138	429
REG220A43A-21	368	158	526
REG300A43A-21	446	211	657
REG370A43A-21	508	184	692
REG450A43A-21	664	218	882
REG550A43A-21	919	257	1176

※ The table shows the required heat dissipation rate due to heat loss for each model when installing single units in a closed space.

※ For multiple units, multiply the heat dissipation rate for single units by the number of units installed. The heat dissipation data are calculated based on each model operating under rated voltage, current, and default carrier wave.

03 Specification





230V Series

Frame		A		B			C	
Model number REG__A23A-21		075	110	150	185	220	300	370
Power rating (kW)		7.5	11	15	18.5	22	30	37
Mains	Input current (A)	20	32	38	49	60	80	100
	Voltage / frequency rating	3-phase AC 200V - 240V (-15% - +10%), 50/60Hz						
	Operation voltage	170~265Vac						
	Frequency Tolerance	47~63Hz						
Feedback activation DC voltage range		300 - 360Vdc (can be adjusted via parameter 01-08)						
Net weight		7.9± 0.5Kg		14.2± 0.5Kg			26.4± 0.5Kg	28.0± 0.5Kg

460V Series

Frame		A			B			C		
Model number REG__A43A-21		075	110	150	185	220	300	370	450	550
Power rating (kW)		7.5	11	15	18.5	22	30	37	45	55
Mains	Input current (A)	10.5	17	20	25	32	43	49	60	75
	Voltage / frequency rating	3-phase AC 380V - 480V (-15% - +10%), 50/60Hz								
	Operation voltage	323~528Vac								
	Frequency Tolerance	47~63Hz								
Feedback activation DC voltage range		580 - 720Vdc (can be adjusted via parameter 01-08)								
Net weight		7.5± 0.5Kg			14.2± 0.5Kg			26.2± 0.5Kg	26.3± 0.5Kg	27.8± 0.5Kg

Common Characteristics

Control method	SVPWM
Brake torque	80% rated input current continuous; 100% rated input current 1min, 25%ED
Overload capacity	150% rated voltage 10sec
Generic input signal	5 channels of signal terminals 24Vdc 6mA
Generic output signal	2 channels of signal terminals 48Vdc 50mA, 1 channel of signal terminal relay output
Cooling method	Forced air cooling
Certifications	    

NOTE

- This product can show current status combining with attached display panel. If you want to execute advance operations and set parameters, please refer to 05 Optional Accessories and purchase a digital keypad.

Environment for Operation, Storage and Transportation

DO NOT expose the Power Regeneration Unit in the bad environment, such as dust, direct sunlight, corrosive/inflammable gasses, humidity, liquid and vibration environment. The salt in the air must be less than $0.01\text{mg}/\text{cm}^2$ every year.

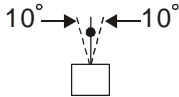
Environmental	Installation location		IEC60364-1/IEC60664-1 Pollution degree 2, Indoor use only
	Surrounding Temperature	Storage	$-25^{\circ}\text{C} \sim +70^{\circ}\text{C}$
		Transportation	$-25^{\circ}\text{C} \sim +70^{\circ}\text{C}$
	Non-condensation, non-frozen		
	Rated Humidity	Operation	Max. 90%
		Storage / Transportation	Max. 95%
		No condense water	
	Air Pressure	Operation / Storage	86 to 106 kPa
		Transportation	70 to 106 kPa
	Pollution Level	IEC721-3-3	
Operation		Class 3C2; Class 3S2	
Storage		Class 2C2; Class 2S2	
Transportation		Class 1C2; Class 1S2	
No concentrate			
Altitude	Operation	If Power Regeneration Unit is installed at altitude 0~1000m, follow normal operation restriction. If it is install at altitude 1000~3000m, decrease 2% of rated current or lower 0.5°C of temperature for every 100m increase in altitude. Maximum altitude for Corner Grounded is 2000m.	
Package Drop	Storage	ISTA procedure 1A (based on weight) IEC60068-2-31	
	Transportation		
Vibration	1.0mm, peak to peak value range from 2Hz to 13.2 Hz; 0.7G~1.0G range from 13.2Hz to 55Hz; 1.0G range from 55Hz to 512 Hz. Comply with IEC 60068-2-6		
Impact	IEC/EN 60068-2-27		
Operating position	Max. allowed offset angle $\pm 10^{\circ}$ (under normal installation position)		

Specification for Operation Temperature and Protection Level

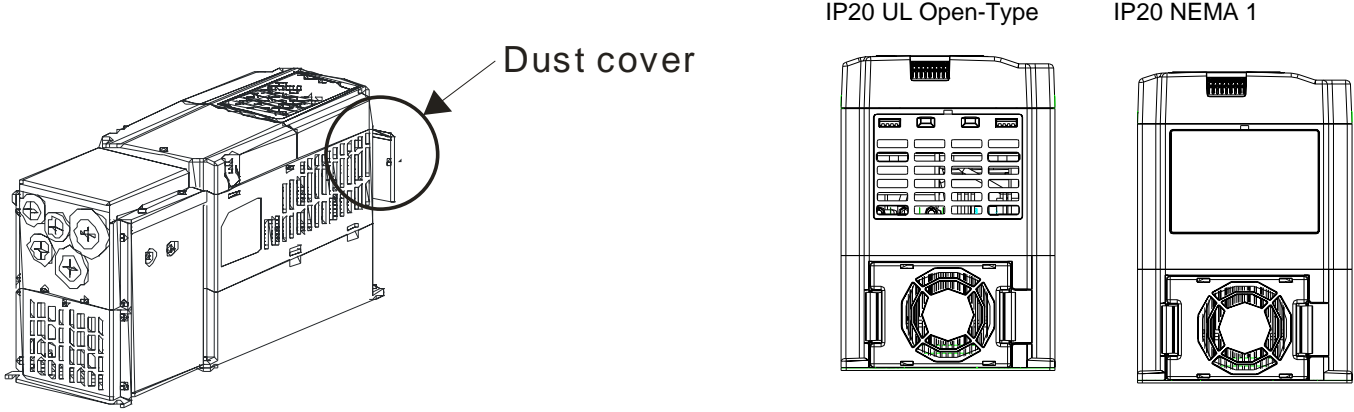

Dust cover	Protection Level	Operation Temp.
with	IP20 NEMA 1	When operating at rated current, the surrounding temperature has to be between -20 °C to +40°C. When the surrounding temperature is over +40°C, decrease 2% of the rated current for every 1°C increase in temperature. The allowable maximum surrounding temperature is 60°C.
without	IP20 UL Open-Type	When operating at rated current, the surrounding temperature has to be between -20 °C to +50°C. When the surrounding temperature is over +50°C, decrease 2% of the rated current for every 1°C increase in temperature. The allowable maximum surrounding temperature is 60°C.

REG Performance Curve

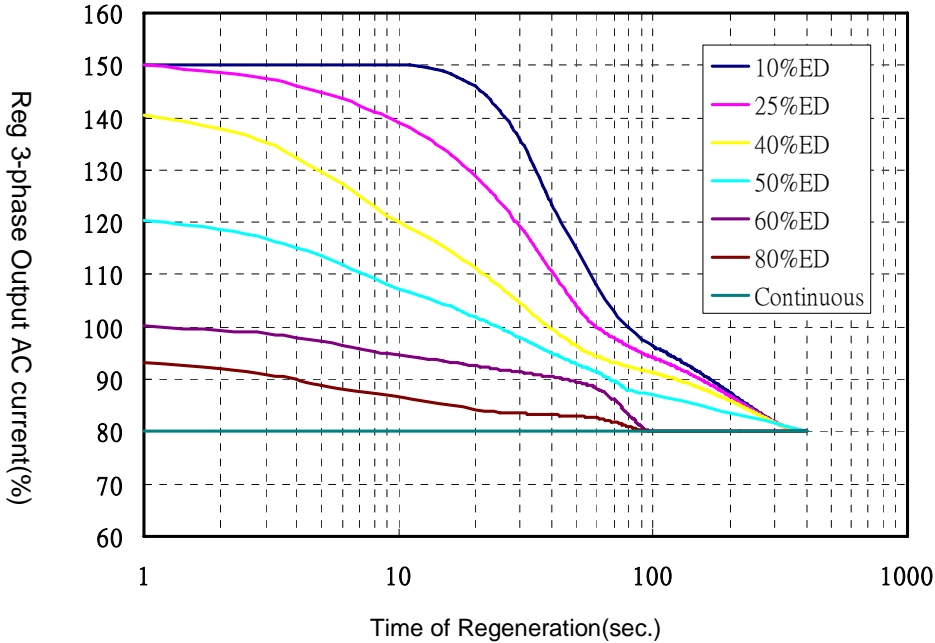

※ The measurement of above plot is to combine REG2000 with DC choke.

04 Wiring

After removing the front cover, examine if the power and control terminals are clearly noted. Please read following precautions before wiring.

- ☑ Make sure that power is only applied to the R/L1, S/L2, T/L3, DC+, and DC- terminals. Failure to comply may result in damage to the equipments. The voltage and current should lie within the range as indicated on the nameplate (Chapter 1-1)..
- ☑ All the units must be grounded directly to a common ground terminal to prevent lightning strike or electric shock.
- ☑ Please make sure to fasten the screw of the main circuit terminals to prevent sparks which is made by the loose screws due to vibration



- ☑ It is crucial to turn off the Power Regeneration Unit power before any wiring installation are made. A charge may still remain in the DC bus capacitors with hazardous voltages even if the power has been turned off therefore it is suggested for users to measure the remaining voltage before wiring. For your personnel safety, please do not perform any wiring before the voltage drops to a safe level < 25 Vdc. Wiring installation with remaining voltage condition may cause sparks and short circuit.
- ☑ Only qualified personnel familiar with Power Regeneration Unit is allowed to perform installation, wiring and commissioning. Make sure the power is turned off before wiring to prevent electric shock.



- ☑ When wiring, please choose the wires with specification that complies with local regulation for your personnel safety.
- ☑ Check following items after finishing the wiring:
 1. Are all connections correct?
 2. Any loosen wires?
 3. Any short-circuits between the terminals or to ground?

4-1 Wiring Diagram

1. Normal Wiring Diagram

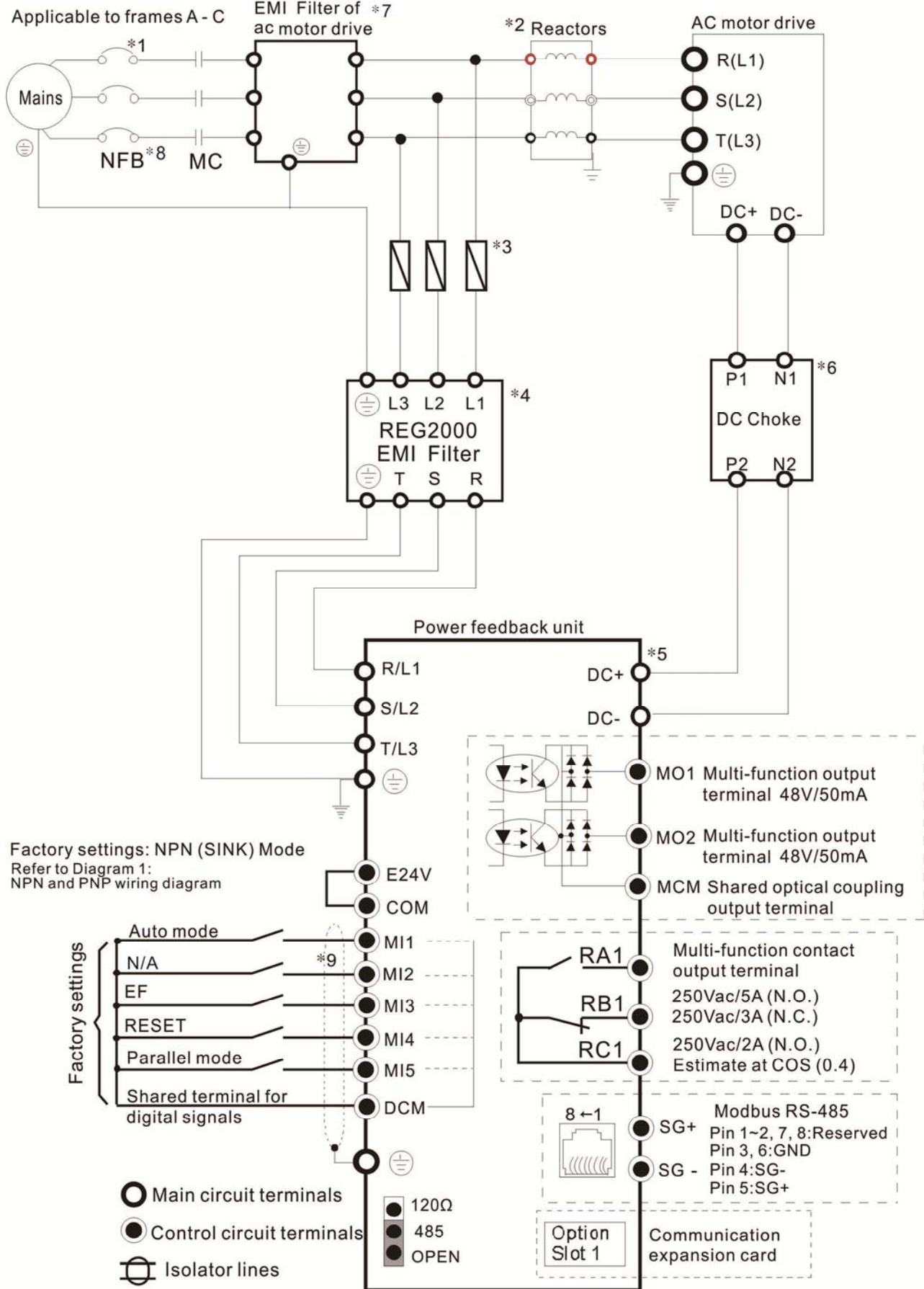

- *1 The NFB can be selected based on the selection of the drive.
- *2 If a reactor is connected to the drive, install the reactor here (optional).
- *3 Please refer to 05 Optional Accessories for the selection of fuses.
- *4 The length between REG2000 EMI filter and power regenerative unit must be less than 10m, and can't provide power to other instruments from here. While using REG2000 EMI filter, please remove the RFI switch on the power regenerative unit.
- *5 The length of the DC+/DC- wires must be less than 5m, and twisted lines are highly recommended.
- *6 There is an attached DC choke to the shipment, please install it as the above normal wiring diagram. The P1,P2,N1,N2 in Normal Wiring Diagram is equal to the terminal 1,2,3,4 in the Dimensions of DC Choke(Diagram 2). Installing the attached DC choke can increase the regenerative efficiency and prevent from electromagnetic interference. The part numbers of DC choke in REG2000 series is in Table 1.
- *7 If there is no REG2000 EMI filter, we recommend using inductors (w/o capacitors) as the EMI filter of AC Motor Drives, in order to avoid capacitors damaged by current ripples.
- *8 If providing power to other instruments is needed, we recommend using the terminals of magnetic contactor (MC) or NFB to connect to other instruments.
- *9 Wiring in auto mode is shown below. Please refer to Pr02-00 ~ Pr02-04 for detailed wiring of multi-function input terminal (MIx, default setting is MI1).

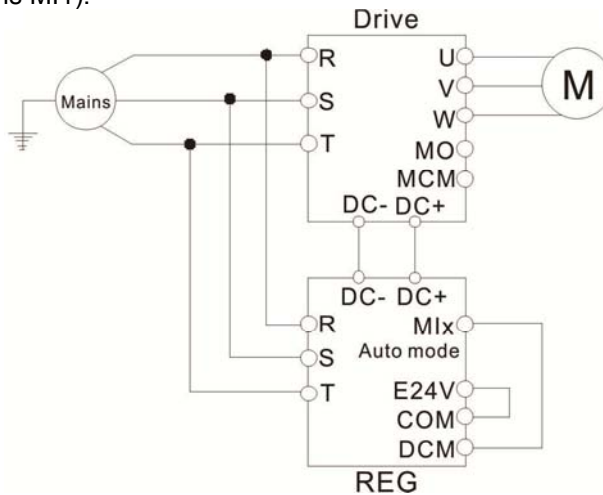

- *10 There are two wiring methods of multi-function input terminal (MIx). Please refer to the following diagrams:

Diagram 1 SINK (NPN) /SOURCE (PNP) Mode switching terminal descriptions

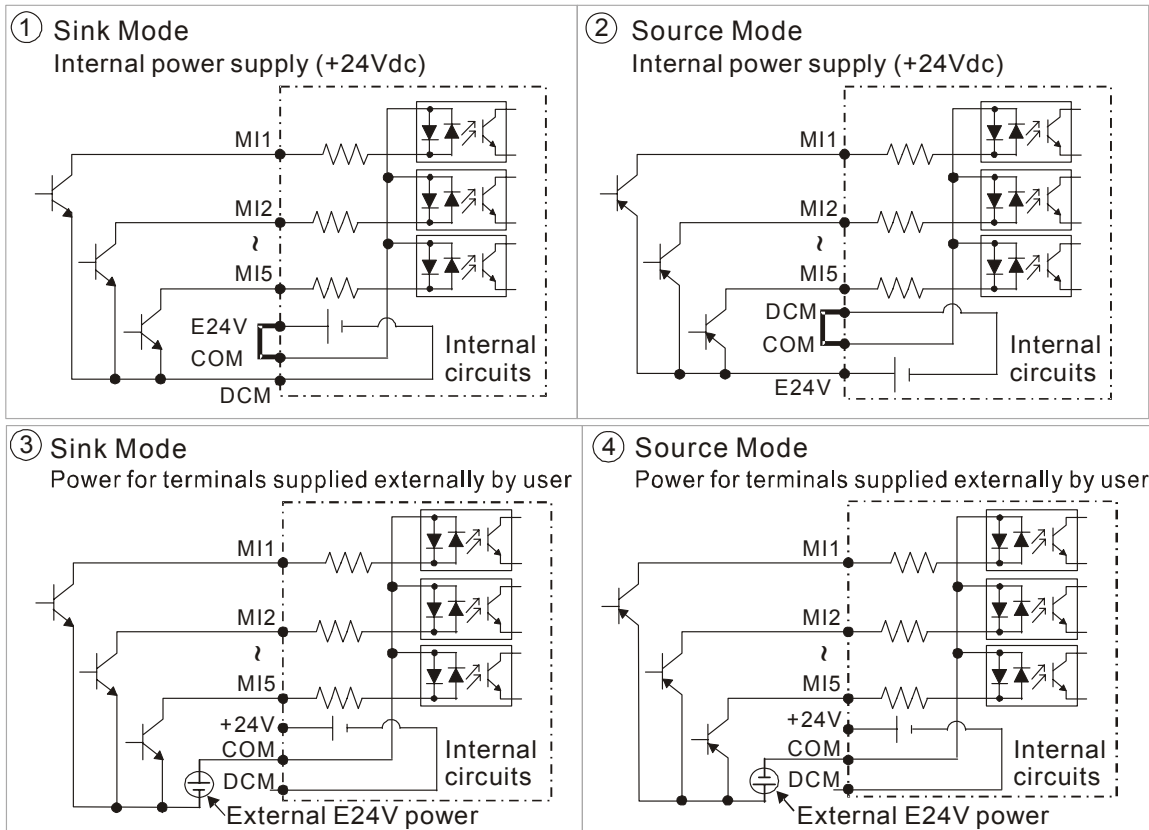
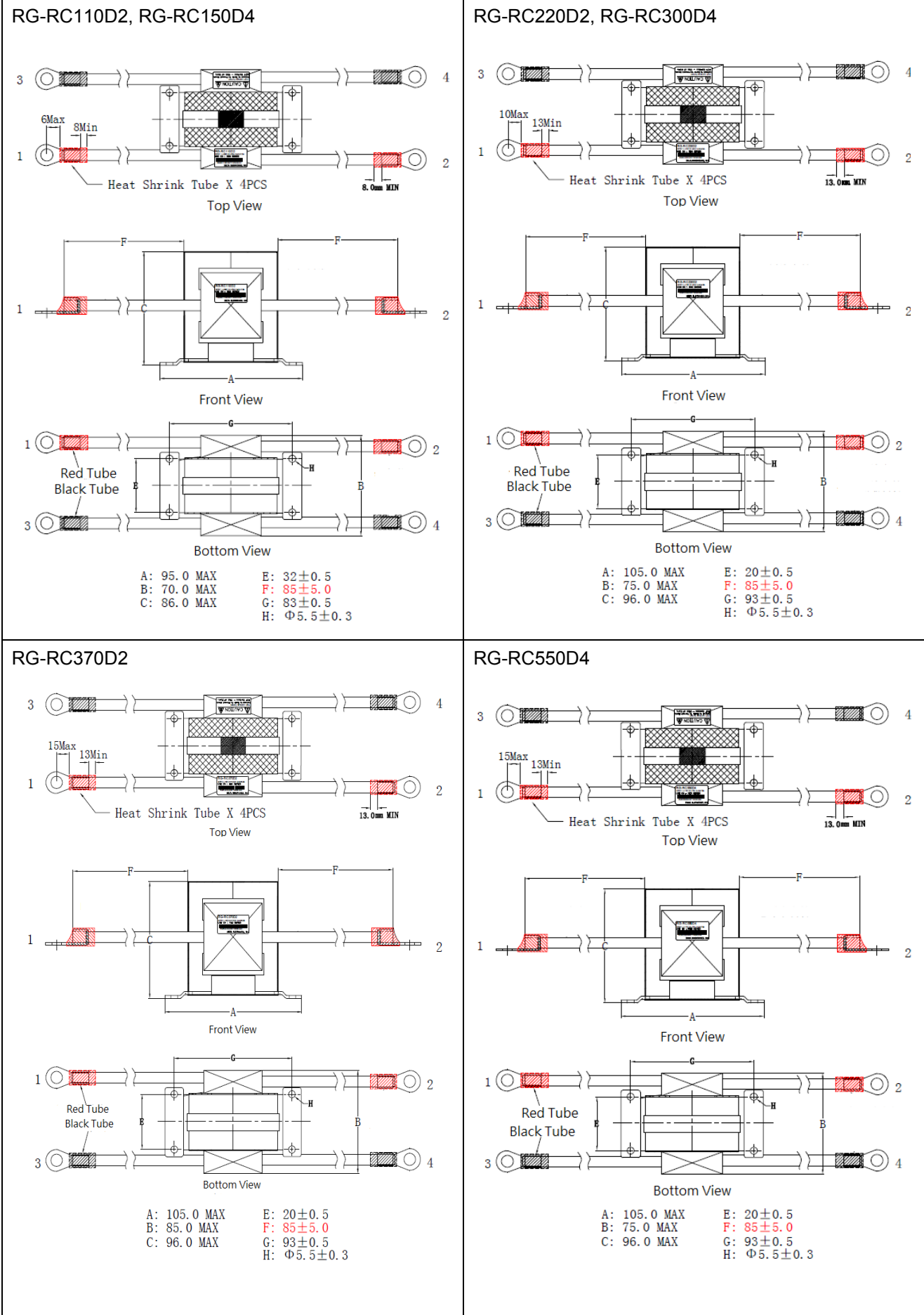

Diagram2 Dimensions of DC chokes



※ Please make sure that P,N terminals (DC Bus) don't short through while installing DC choke.

Table 1 The part numbers of DC choke in REG2000 series

REG Model	PN. of attached DC choke
REG075A23A-21	RG-RC110D2
REG110A23A-21	
REG150A23A-21	RG-RC220D2
REG185A23A-21	
REG220A23A-21	
REG300A23A-21	RG-RC370D2
REG370A23A-21	
REG075A43A-21	RG-RC150D4
REG110A43A-21	
REG150A43A-21	
REG185A43A-21	RG-RC300D4
REG220A43A-21	
REG300A43A-21	
REG370A43A-21	RG-RC550D4
REG450A43A-21	
REG550A43A-21	

2. Multi-AC Motor Drives Wiring Diagram

※ Points for Attention:

1. Please refer to this diagram to wire up.
2. Please make sure that your AC motor drives can operate in common DC bus at first. And be aware that the ratings of rectifier or AC motor drives are properly chosen.
3. In order to choose proper power regenerative unit, please confirm the maximum regenerative energy while all AC motor drives work at the same time firstly.
4. For one-to-many installation, it is recommended to install a fuse, i.e. fuse_A/B/C..., at the DC input side of every drive. Please calculate and select a suitable fuse for your every drive: Fuse type = (Rated input current of drive) x 2.5.

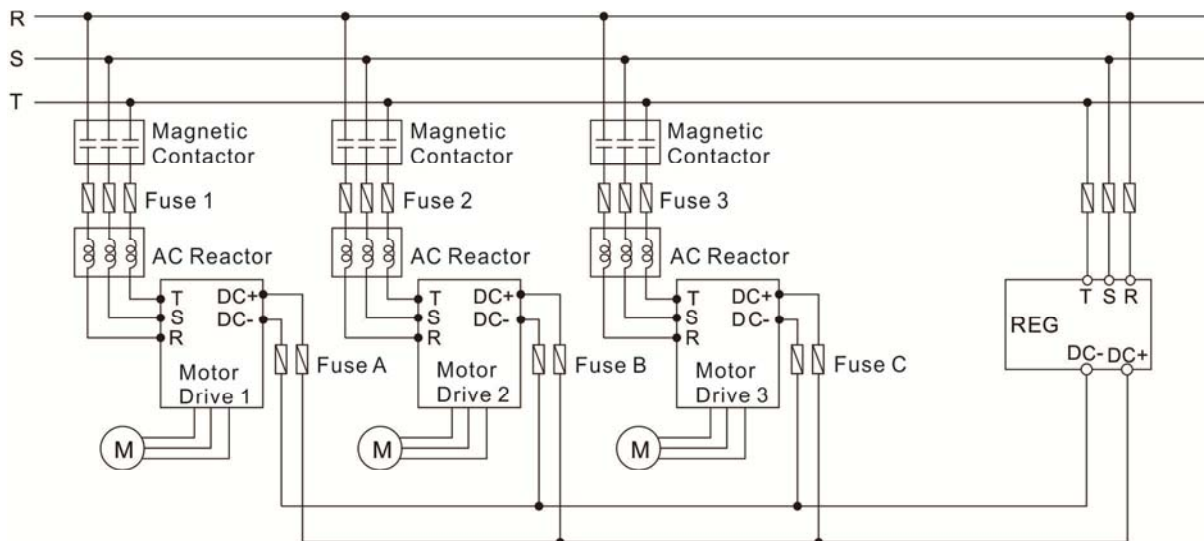

3. Multi-REG2000 Wiring Diagram

※ Points for Attention:

1. Support maximum 4 power regenerative units working in parallel at the same time.
2. DC choke is required, and please install DC choke as near each power regenerative unit as better.
3. Please refer to the following diagram. Instead of directly coming from power regenerative unit 1, the wiring which connects to power regenerative unit 2 shall come from the DC bus of the AC motor drive. In addition, using copper bars for wiring are highly recommended.
4. Wiring in parallel mode is shown below. Please refer to Pr02-00 ~ Pr02-04 for detailed wiring of multi-function input terminal (MIx, default setting is MI5). Working in parallel, each power regenerative unit will reduce its current limit to 80% automatically.

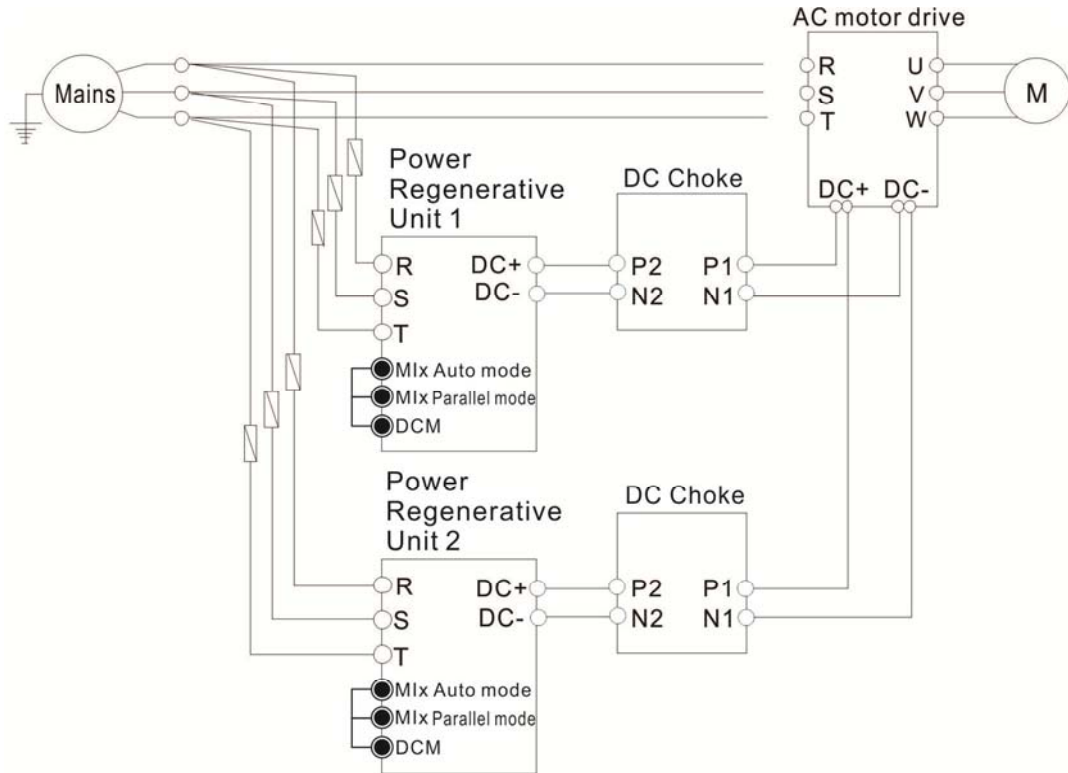

4-2 Main Circuit Terminals

Please remove the top cover before wiring the main circuit terminals.

The unit appearances shown in the figures are for reference only, a real drive may look different.

Removing the outer cover for wiring

1) Screw torque: 14~16Kg-cm [12.15~13.88lb-in.] (1.37~1.57 Nm) After loosening the screws, remove the wiring top cover as shown in the diagrams below

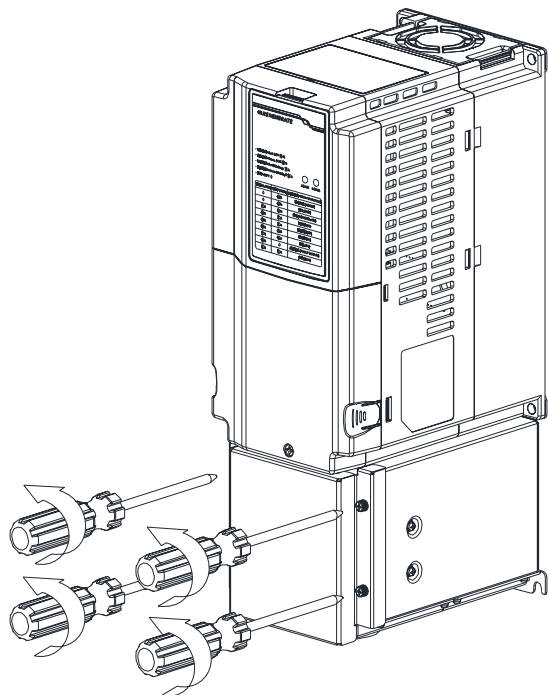

Frame A, B,

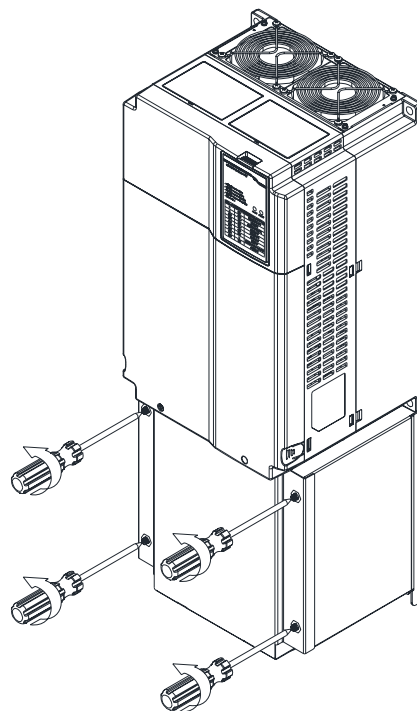

Frame C

2) After loosening the screws, remove the wiring top cover as shown in the diagrams below

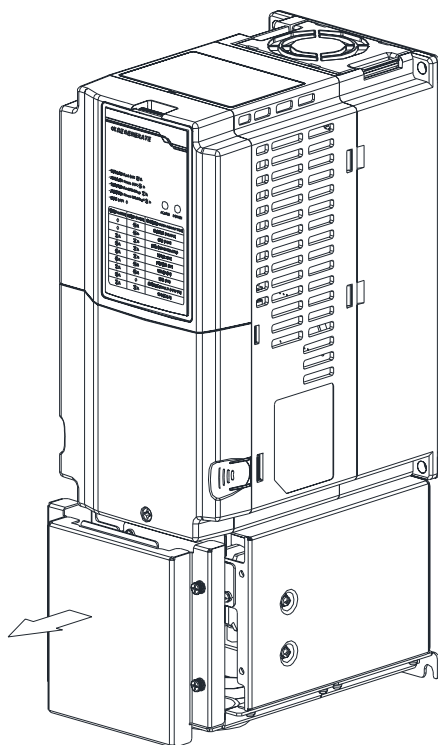

Frame A, B,

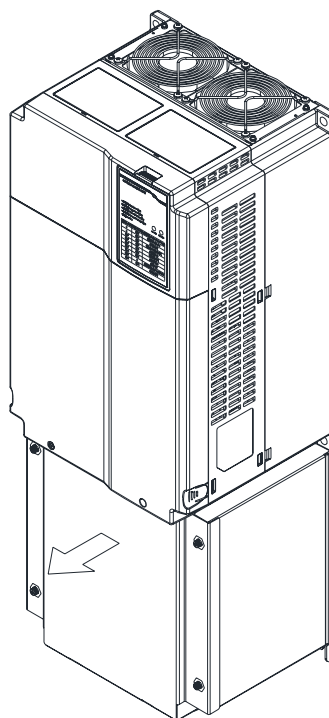

Frame C

3) Loosen the screws to wire the main circuit terminals

Frame A, screw torque: 6~8Kg-cm [5.2~6.9lb-in.] (0.59~0.78 Nm)

Frame B, screw torque: 14~16Kg-cm [12.15~13.88lb-in.] (1.37~1.57 Nm)

Frame C, screw torque: 10~12Kg-cm [8.68~10.42lb-in.] (0.98~1.18 Nm)

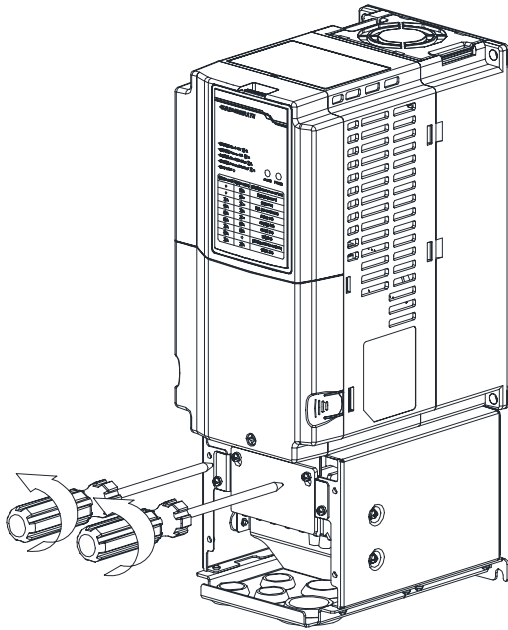

Frame A, B,

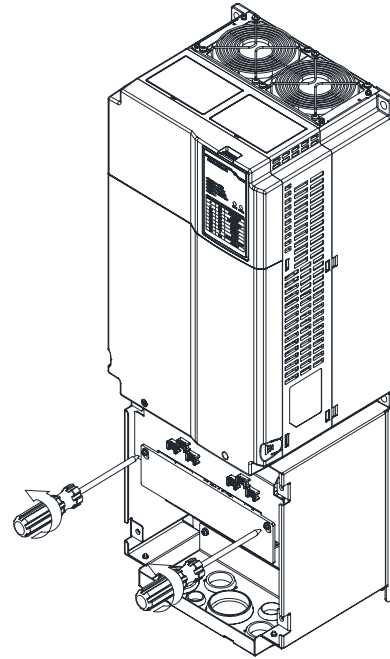

Frame C

Main Circuit Terminal Diagram

Applicable to frames A - C

Provides three-phase power input

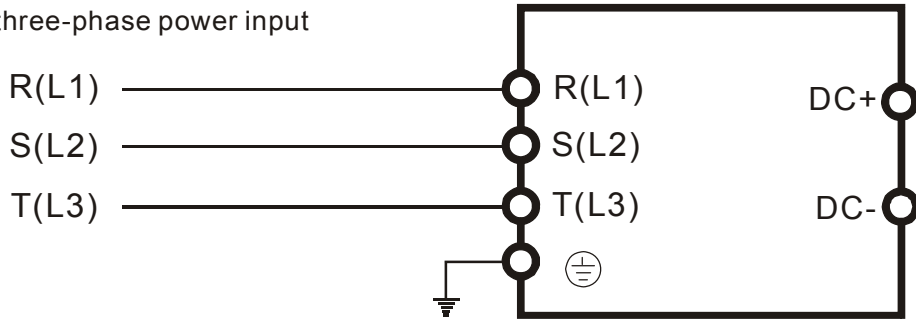

Terminal labels	Descriptions
R/L1, S/L2, T/L3	AC line input terminals 3-phase
DC+, DC-	Connect to the AC motor drive's terminals DC+ and DC- respectively. There is a build-in fuse, which can prevent from damaging AC motor drive when REG malfunctions, in the internal hardware circuit.
⊕	Earth connection, please comply with local regulations.

Main Circuit Terminal Specifications

Frame A

Main Circuit Terminals:

R/L1, S/L2, T/L3 ⊕, DC+, DC-

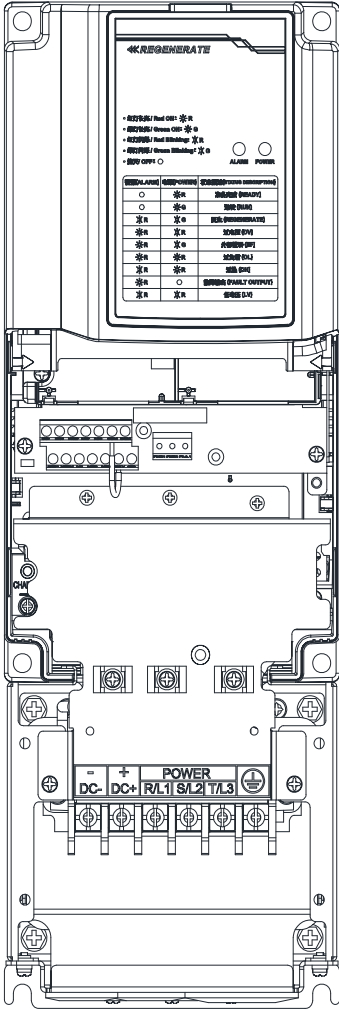

Model	Maximum wire diameter	Minimum wire diameter	Torque (±10%)
REG075A23A-21;	8 AWG (8.4mm ²)	10 AWG (5.3mm ²)	M4 20kg-cm (17.4 lb-in.) (1.96Nm)
REG110A23A-21;		8 AWG (8.4mm ²)	
REG075A43A-21;		14 AWG (2.1mm ²)	
REG110A43A-21;		10 AWG (5.3mm ²)	
REG150A43A-21;		10 AWG (5.3mm ²)	

UL installations must use 600V, 75°C or 90°C wire. Use copper wire only. 8 AWG wire must use ring lug.

The diagrams below on the right are specifications for insulated heat shrink tubing that comply with UL (600V, YDPU2).

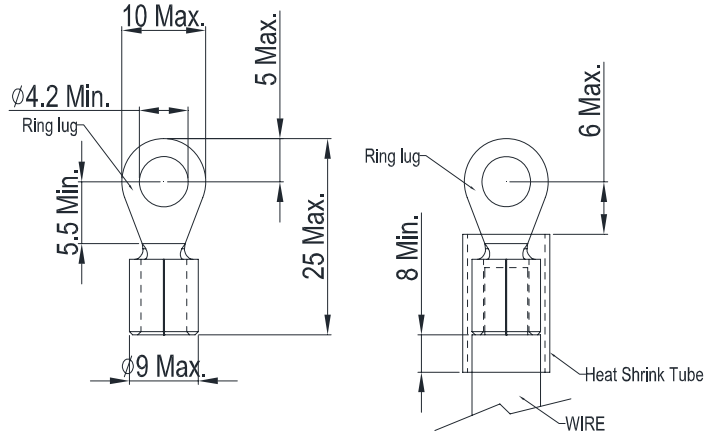

Frame B

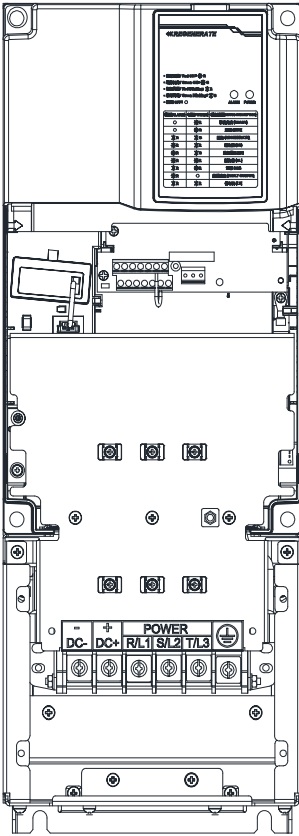

Main Circuit Terminals:

R/L1, S/L2, T/L3, ⊕, DC+, DC-

Model	Maximum wire diameter	Minimum wire diameter	Torque (±10%)
REG150A23A-21;	4 AWG (21.2mm ²)	6 AWG (13.3mm ²)	M6 35kg-cm (30.4 lb-in.) (3.434Nm)
REG185A23A-21;		4 AWG (21.2mm ²)	
REG220A23A-21;		4 AWG (21.2mm ²)	
REG185A43A-21;		8 AWG (8.4mm ²)	
REG220A43A-21;		8 AWG (8.4mm ²)	
REG300A43A-21;		6 AWG (13.3mm ²)	

UL installations must use 600V, 75°C or 90°C wire. Use copper wire only.
REG220A23A-21 must use 90φJ wire.

 **NOTE**

The diagrams below on the right are specifications for insulated heat shrink tubing that comply with UL (600V, YDPU2)..

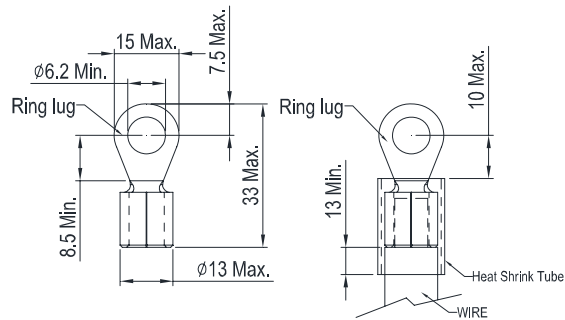

Frame C

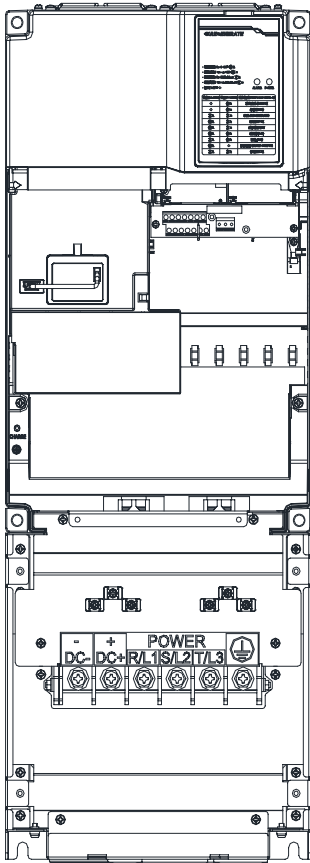

Main Circuit Terminals:

R/L1, S/L2, T/L3, ⊕, DC+, DC-

Model	Maximum wire diameter	Minimum wire diameter	Torque (±10%)
REG300A23A-21;	1/0 AWG (53.5mm ²)	2 AWG (33.6mm ²)	M8 81.5kg-cm (70.8 lb-in.) (8Nm)
REG370A23A-21;		1/0 AWG (53.5mm ²)	
REG370A43A-21;		4 AWG (21.2mm ²)	
REG450A43A-21;		3 AWG (26.7mm ²)	
REG550A43A-21;		2 AWG (33.6mm ²)	

UL installations must use 600V, 75°C or 90°C wire. Use copper wire only.

NOTE

The diagrams below on the right are specifications for insulated heat shrink tubing that comply with UL (600V, YDPU2).

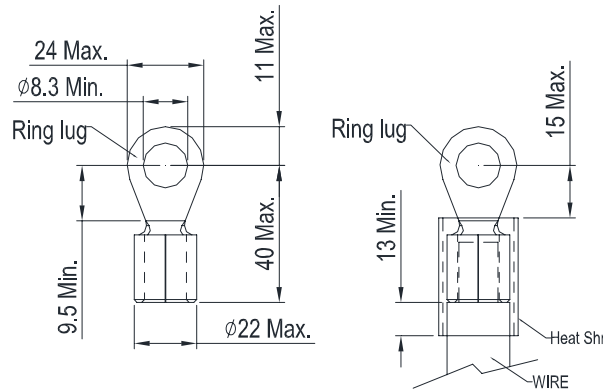

Main circuit power input terminals:

- ☑ Do not connect 3-phase model to one-phase power. R/L1, S/L2 and T/L3 has no phase-sequence requirement, it can be used upon random selection.
- ☑ It is recommend to add a magnetic contactor (MC) to the power input wiring to cut off power quickly and reduce malfunction when activating the protection function of the Power Regeneration Unit. Both ends of the MC should have an R-C surge absorber.
- ☑ Fasten the screws in the main circuit terminal to prevent sparks condition made by the loose screws due to vibration.
- ☑ Lease use voltage and current within the specification.
- ☑ When using a general GFCI (Ground Fault Circuit Interrupter), select a current sensor with sensitivity of 200mA or above and not less than 0.1-second operation time to avoid nuisance tripping.
- ☑ Please use the shield wire or tube for the power wiring and ground the two ends of the shield wire or tube.

4-3 Control Circuit Terminals

Please remove the top cover before wiring the multi-function input and output terminals

The unit appearances shown in the figures are for reference only, a real drive may look different.

Removing the outer cover for wiring

1) Screw torque: 14~16Kg-cm [12.15~13.88lb-in.] (1.37~1.57 Nm) After loosening the screws, remove the wiring top cover as shown in the diagrams below

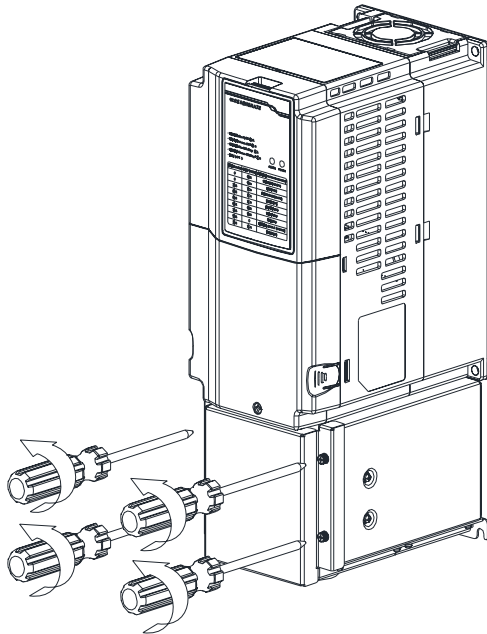

Frame A, B,

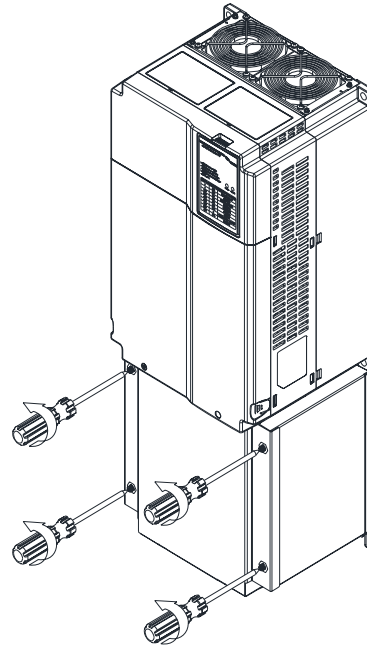

Frame C

2) After loosening the screws, remove the wiring top cover as shown in the diagrams below

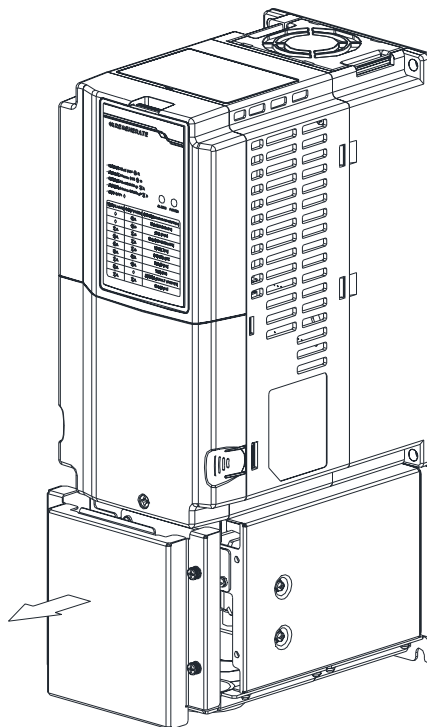

Frame A, B,

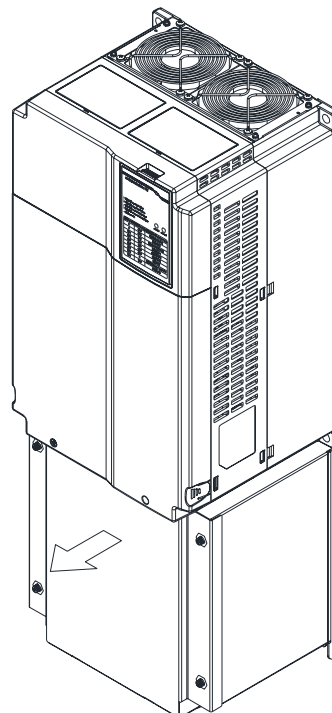

Frame C

3) Loosen the screws

Frames A, B, C Screw torque: 10~12Kg-cm [8.68~10.42lb-in.] (0.98~1.18 Nm)

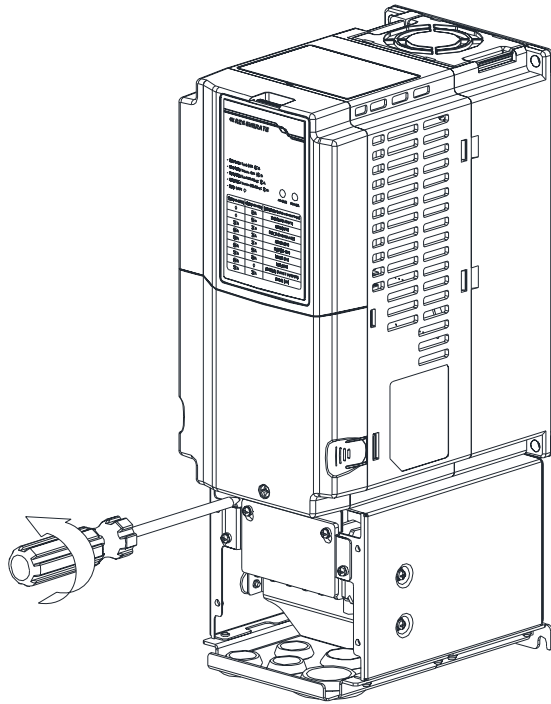

Frame A, B,

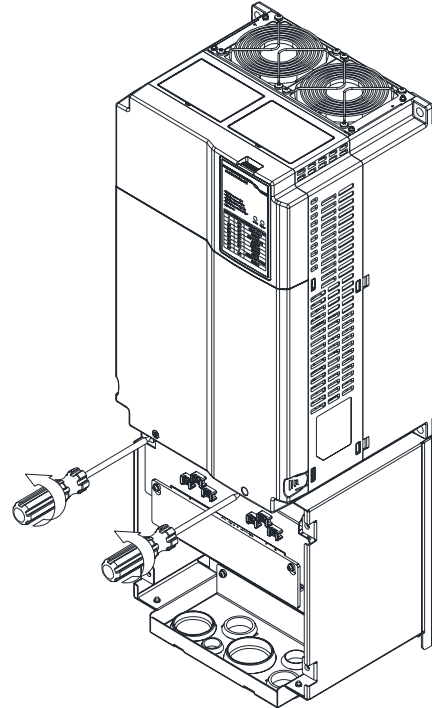

Frame C

4) Control terminals can now be wired

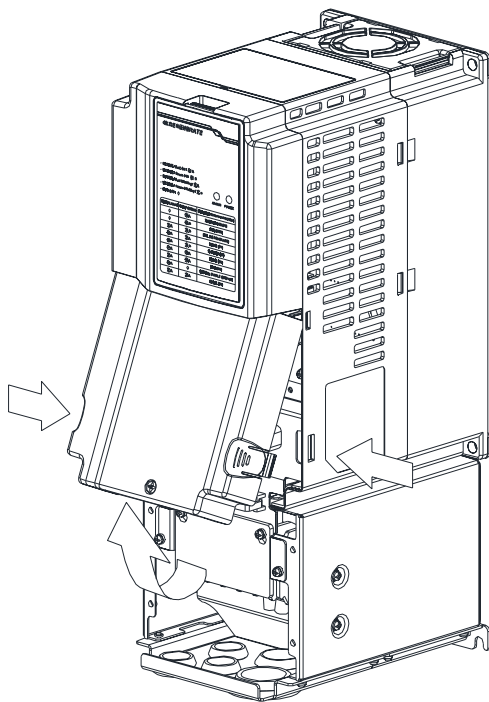

Frame A, B,

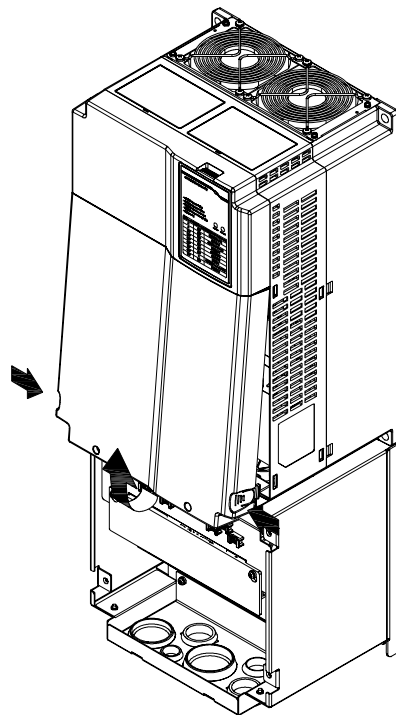

Frame C

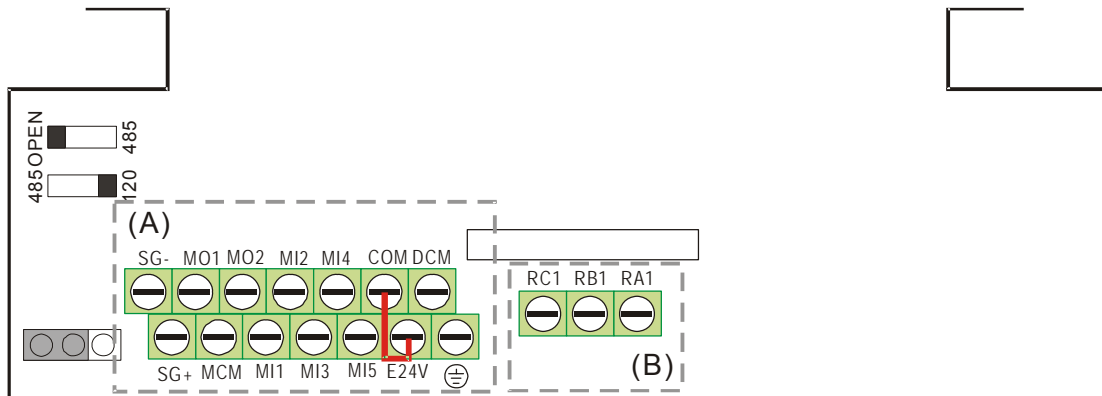

Control Terminal Specifications

Wire Gauge: 26~16AWG; [0.1281-1.318mm²];

Torque: (A) 5.6kg-cm [4.86lb-in.] (0.55Nm) (As shown in figure above)

(B) 5.1kg-cm [4.43lb-in.] (0.5Nm) (As shown in figure above)

Wiring notes:

- The factory setting for E24V-COM is short circuit and SINK mode (NPN); please refer to Diagram 1 in Wiring.

Terminal	Description of Function	Factory setting (NPN mode)
E24V	The factory setting for +24V-COM is short circuit and SINK mode (NPN); (Source)	+24V±5% 200mA
COM	Digital control signal common (Sink)	Common for multi-function input terminals
MI1 ~ MI5	Multi-function input 1-5	Refer to parameters 02-00 - 02-04 to program the multi-function inputs MI1-MI5. ON: the activation current is 6.5mA ≥ 11Vdc; OFF: leakage current tolerance is 10μA ≤ 5Vdc
DCM	Common terminal for digital control signals (Sink)	Common terminal for multi-function input
MO1	Multi-function output 1 (photocoupler)	The Power Regeneration Unit releases various monitor signals, via transistor (open collector).
MO2	Multi-function output 2 (photocoupler)	Max 48Vdc 50mA
MCM	Multi-function Output Common	
RA1	Multi-function relay output 1 (N.O.) a	Resistive load
RB1	Multi-function relay output 1 (N.C.) b	5A(N.O.)/3A(N.C.) 250VAC

Terminal	Description of Function	Factory setting (NPN mode)
RC1	Multi-function relay common	5A(N.O.)/3A(N.C.) 30VDC Inductive load (COS 0.4) 2.0A(N.O.)/1.2A(N.C.) 250VAC 2.0A(N.O.)/1.2A(N.C.) 30VDC Outputs various monitoring signals.
SG+	Modbus RS-485	
SG-	PIN 1,2,7,8: Reserved PIN 4: SG-	PIN 3, 6: GND PIN 5: SG+

NOTE: Wire size of analog control signals: 18 AWG (0.75 mm²) with shielded wire

Digital inputs (MI1~MI5, COM)

- When using contacts or switches to control the digital inputs, please use high quality components to avoid contact bounce.

Transistor output terminals (MO1, MO2, MCM)

- Make sure to connect the digital outputs to the right polarity.
- When connecting a relay to the digital outputs connect a surge absorber across the coil and check the polarity.

4-4 Display Panel Indicators

Display panel information



Power & alarm indicator status descriptions

Alarm	Power	Description
OFF	Red ON	Ready
OFF	Green ON	RUN
Red Blinking	Green Blinking	REGENERATE
Red ON	Red Blinking	OV
Red ON	Green Blinking	EF
Red ON	Red ON	OL
Red Blinking	Red ON	OH
Red ON	OFF	Fault Output
Red Blinking	Red Blinking	LV
Red Blinking	OFF	PHL & PLE
OFF	Green Blinking	Other Error

Diagram 3 The definitions of every state of power regeneration.

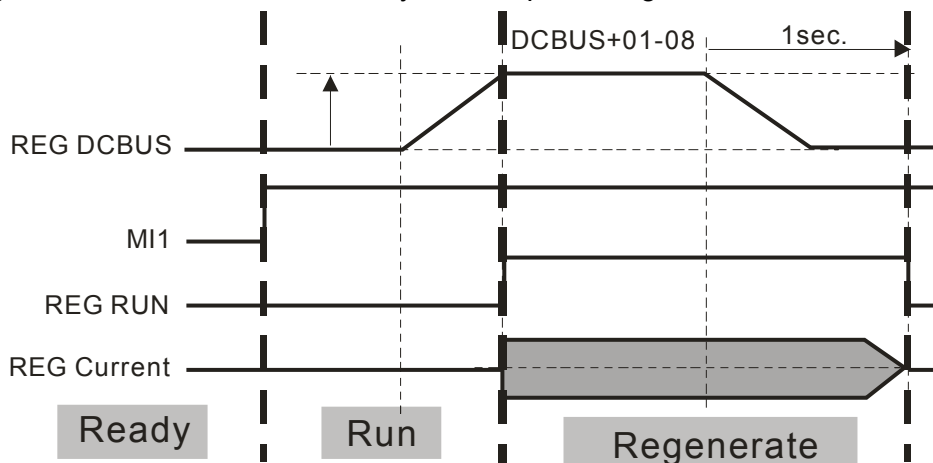

05 Optional Accessories

The optional accessories listed in this chapter are available upon request. Installing additional accessories to your Power Regeneration Unit would substantially improve the unit's performance. Please select an applicable accessory according to your need or contact the local distributor for suggestion.

Optional Accessories

5-1 Digital keypad

5-2 USB/RS485 Communication Interface IFD6530

5-3 Fuse Specification Chart

5-4 REG 2000EMI filter

5-1 Digital Keypad

KPC-CC01

KPC-CE01



Communication interface
RJ-45 (socket), RS-485 interface;

Installation Method

- Embedded type and can be put flat on the surface of the control box. The front cover is water proof.

Keys	Description				
ESC	ESC Key Press ESC key to return to the previous page. It also functions as a return to last category key in the sub-menu.				
MENU	Menu Key Press MENU key under any condition will return to the main MENU. Menu content: <table style="width: 100%; border: none;"> <tr> <td style="width: 50%;">1. Parameter Detail</td> <td style="width: 50%;">3. Keypad locked</td> </tr> <tr> <td>2. Copy Parameter</td> <td>4. PLC function</td> </tr> </table>	1. Parameter Detail	3. Keypad locked	2. Copy Parameter	4. PLC function
1. Parameter Detail	3. Keypad locked				
2. Copy Parameter	4. PLC function				
ENTER	ENTER Key Press ENTER and go to the next level. If it is the last level then press ENTER to execute the command.				
HAND	No assigned function				
AUTO	No assigned function				
FWD/REV	No assigned function				
RUN	Start Key <ul style="list-style-type: none"> <input checked="" type="checkbox"/> It is only valid when the source of operation command is from the keypad. <input checked="" type="checkbox"/> Press the RUN key, the drive will according to the start-up setting and the RUN LED will be ON. <input checked="" type="checkbox"/> RUN key can be pressed for many times when the Power Regeneration Unit is in stop status. 				
STOP	Stop Key <ul style="list-style-type: none"> <input checked="" type="checkbox"/> STOP key has the highest priority in command. <input checked="" type="checkbox"/> Press STOP key, the Power Regeneration Unit will come to stop under any condition. <input checked="" type="checkbox"/> The RESET key can be used to reset the Power Regeneration Unit when faults occur. If the RESET key is not responding, check MENU → Fault Records and check the most recent fault. 				

KPC-CC01& KPC-CE01 Dimension

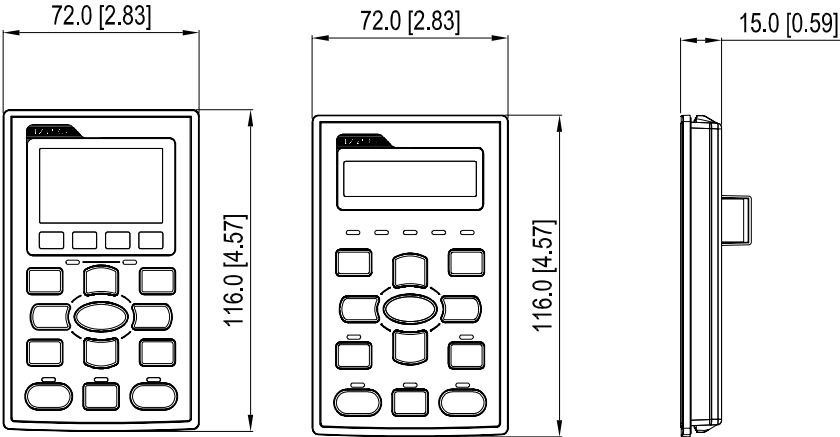

Optional RJ45 extension cable for the digital keypad

Part numbers	Description
CBC-K3FT	3 feet RJ45 extension lead (approximately 0.9m)
CBC-K5FT	5 feet RJ45 extension lead (approximately 1.5 m)
CBC-K7FT	7 feet RJ45 extension lead (approximately 2.1 m)
CBC-K10FT	10 feet RJ45 extension lead (approximately 3 m)
CBC-K16FT	16 feet RJ45 extension lead (approximately 4.9 m)

5-2 USB/RS-485 Communication Interface IFD6530

Caution

- ✓ Please thoroughly read this instruction sheet before installation and putting it into use.
- ✓ The content of this instruction sheet and the driver file may be revised without prior notice. Please consult our distributors or download the most updated instruction/driver version at http://www.delta.com.tw/product/em/control/cm/control_cm_main.asp

Introduction

IFD6530 is a convenient RS-485-to-USB converter, which does not require external power-supply and complex setting process. It supports baud rate from 75 to 115.2kbps and auto switching direction of data transmission. In addition, it adopts RJ-45 in RS-485 connector for users to wire conveniently. And its tiny dimension, handy use of plug-and-play and hot-swap provide more conveniences for connecting all DELTA IABU products to your PC.

Applicable Models: All DELTA IABU products.

■ Applications and Dimensions

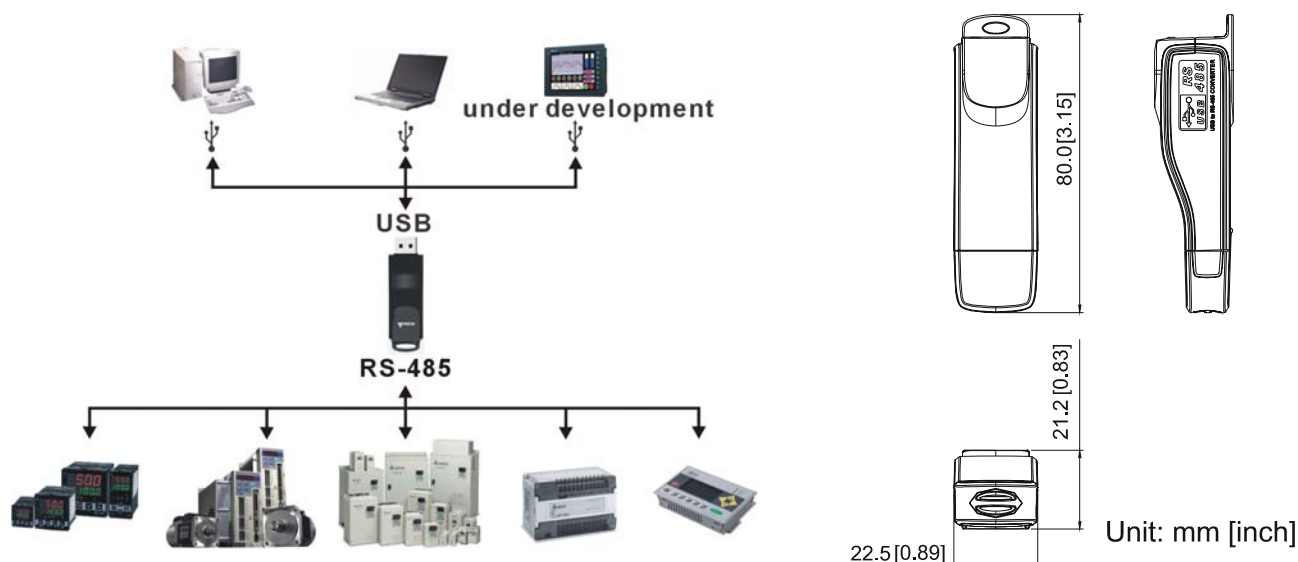

Functional Specifications

Power supply	No external power is needed
Power consumption	1.5W
Isolation voltage	2,500VDC
Baud rate	75,150,300,600,1,200,2,400,4,800,9,600,19,200,38,400,57,600,115,200 bps
RS-485 connector	RJ-45
USB port	A type (plug)
Compatibility	Full compliance with USB V2.0 specification
Max. cable length	RS-485 Communication Port: 100 m
Support RS-485 half-duplex transmission	

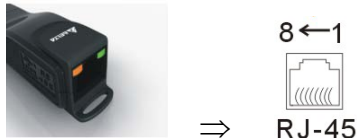
RJ-45

PIN	Description	PIN	Description
1	Reserved	5	SG+
2	Reserved	6	GND
3	GND	7	Reserved
4	SG-	8	+9V

Preparations Before Driver Installation

Please extract the driver file (IFD6530_Drivers.exe) by following steps. You could find driver file (IFD6530_Drivers.exe) in the CD supplied with IFD6530.

Note: DO NOT connect IFD6530 to PC before extracting the driver file.

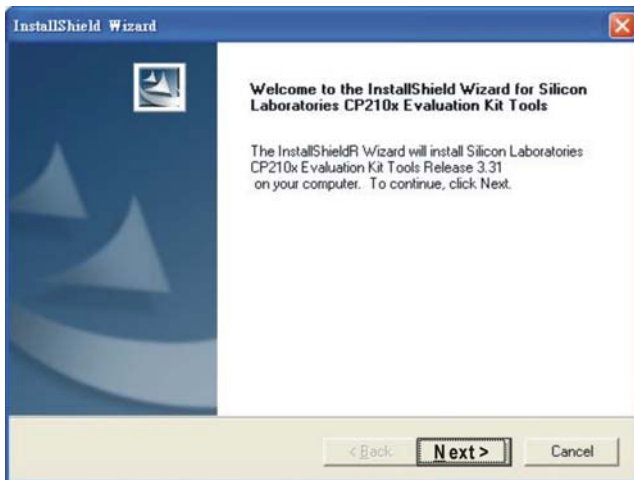
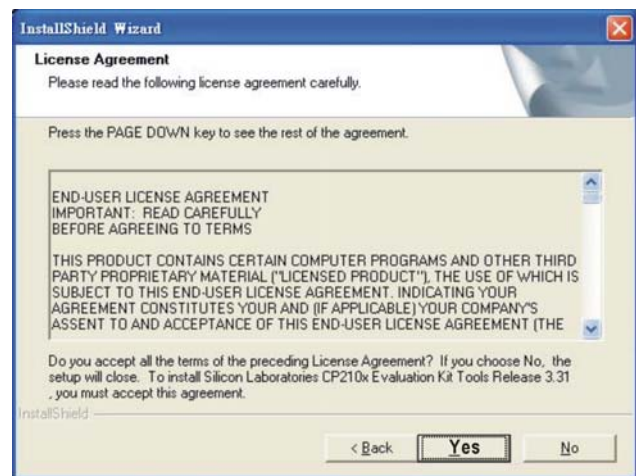
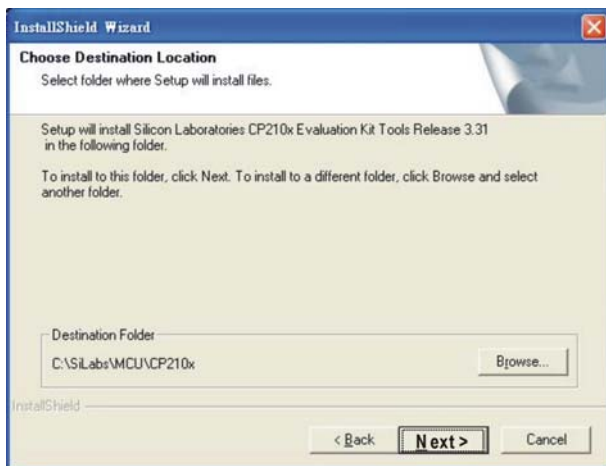
STEP 1**STEP 2****STEP 3****STEP 4****STEP 5**

You should have a folder marked SiLabs under drive C. c:\ SiLabs

Driver Installation

After connecting IFD6530 to PC, please install driver by following steps.

STEP 1



STEP 2

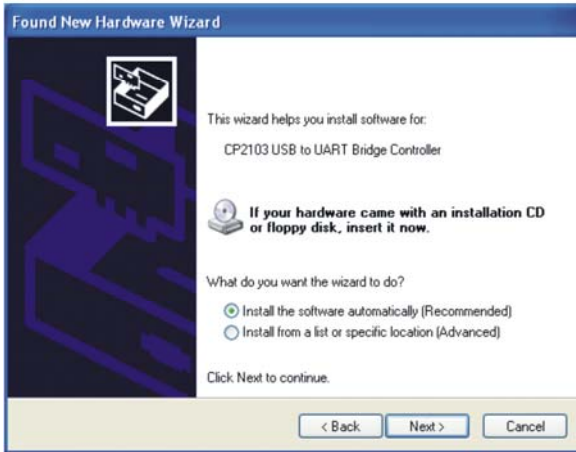

OR

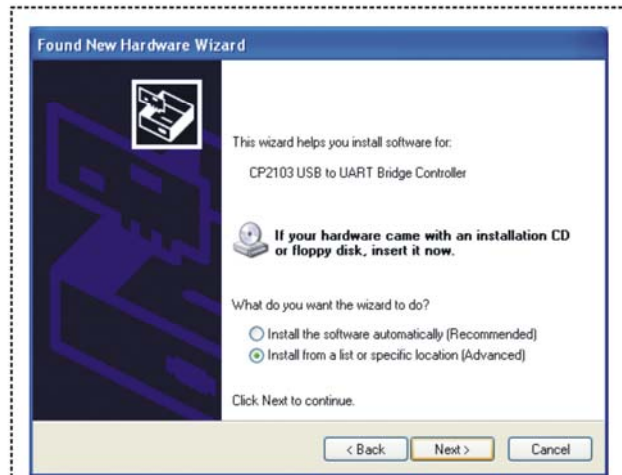

Browse and select directory, or enter
C:\SiLabs\MCU\CP210x\WIN

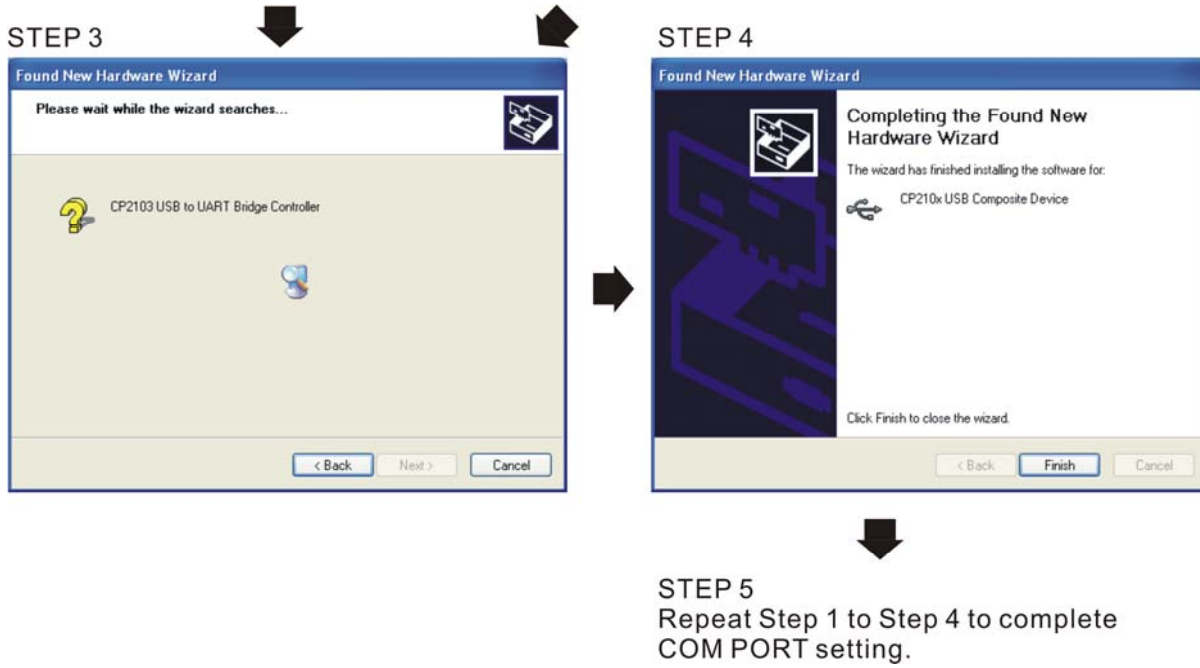

LED Display

1. Steady Green LED ON: power is ON.
2. Blinking orange LED: data is transmitting.

5-3 Fuse Specification Chart

- The fuses with amperes smaller than the those listed in the table below are allowed.
- Use only the fuses comply with UL certificated.
- Use only the fuses comply with local regulations.

Frame A	
Model No.	Ampere
REG075A23A-21	50
REG110A23A-21	80
REG075A43A-21	25
REG110A43A-21	45
REG150A43A-21	50

Frame B	
Model No.	Ampere
REG150A23A-21	100
REG185A23A-21	125
REG220A23A-21	150
REG185A43A-21	60
REG220A43A-21	80
REG300A43A-21	100

Frame C	
Model No.	Ampere
REG300A23A-21	200
REG370A23A-21	250
REG370A43A-21	125
REG450A43A-21	150
REG550A43A-21	200

5-4 REG2000 EMI Filter

EMI filter specifications

REG2000 Model	REG EMI Filter	Weight(kg)
REG075A23A-21	RG-EF110A2	3.2±0.5
REG110A23A-21		
REG150A23A-21	RG-EF220A2	4.8±0.5
REG185A23A-21		
REG220A23A-21		
REG300A23A-21		
REG370A23A-21	RG-EF370A2	6.0±0.5
REG075A43A-21	RG-EF150A4	3.2±0.5
REG110A43A-21		
REG150A43A-21		
REG185A43A-21	RG-EF300A4	4.8±0.5
REG220A43A-21		
REG300A43A-21		
REG370A43A-21		
REG450A43A-21	RG-EF550A4	6.0±0.5
REG550A43A-21		

Model	Wiring Spec.		Torque (±10%)
	Max. Wiring Diameter	Min. Wiring Diameter	
REG2000 Frame A			
RG-EF110A2	8 AWG (8.4mm ²)	8 AWG (8.4mm ²)	M4 14~16kg-cm
RG-EF150A4		10 AWG (5.3mm ²)	
REG2000 Frame B			
RG-EF220A2	4 AWG (21.2mm ²)	4 AWG (21.2mm ²)	M5 30~34kg-cm
RG-EF300A4		6 AWG (13.3mm ²)	
REG2000 Frame C			
RG-EF370A2	1/0 AWG (53.5mm ²)	1/0 AWG (53.5mm ²)	M6 60~69kg-cm
RG-EF550A4		2 AWG (33.6mm ²)	
※ UL installations must use 600V, 75°C or 90°C wire. Use copper wire only.			
※ RG-EF110A2 and RG-EF220A2 must use 90°C wire.			

※ Please refer to 4-1 Normal Wiring Diagram for more wiring details.

REG2000 EMI Filter Dimension

RG-EF110A2; RG-EF150A4;

Unit: mm[inch]

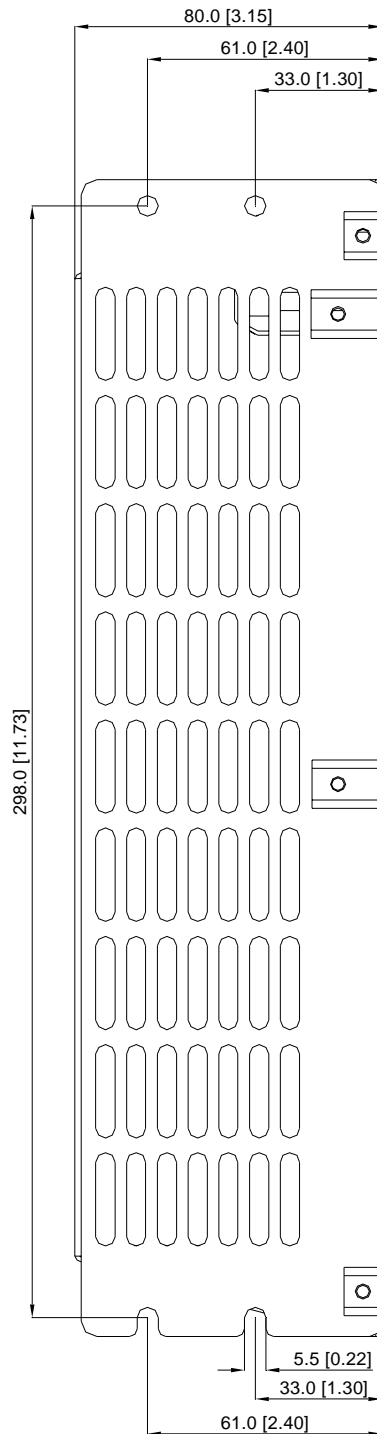
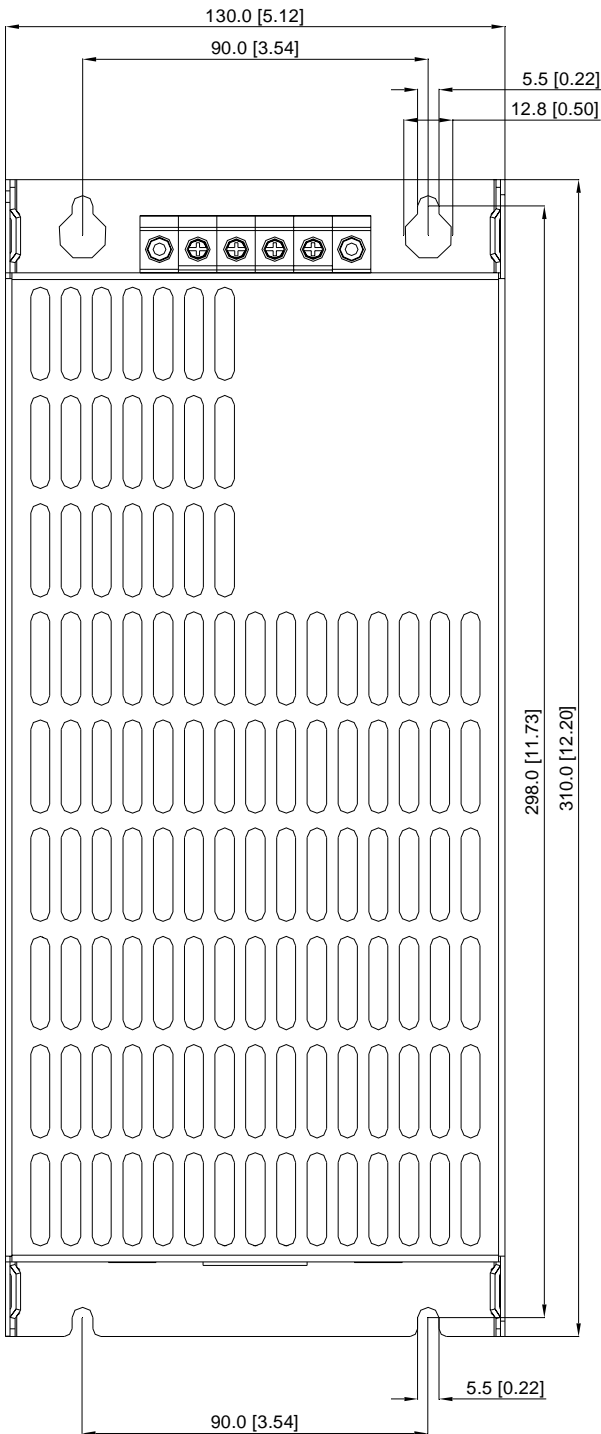
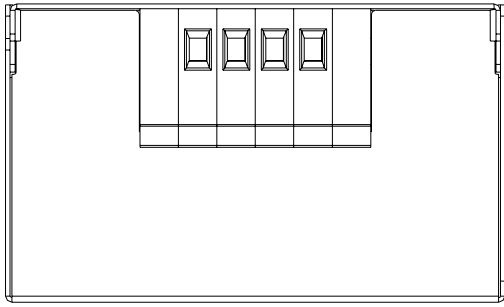

RG-EF220A2; RG-EF370A2; RG-EF300A4; RG-EF550A4

Unit: mm[inch]

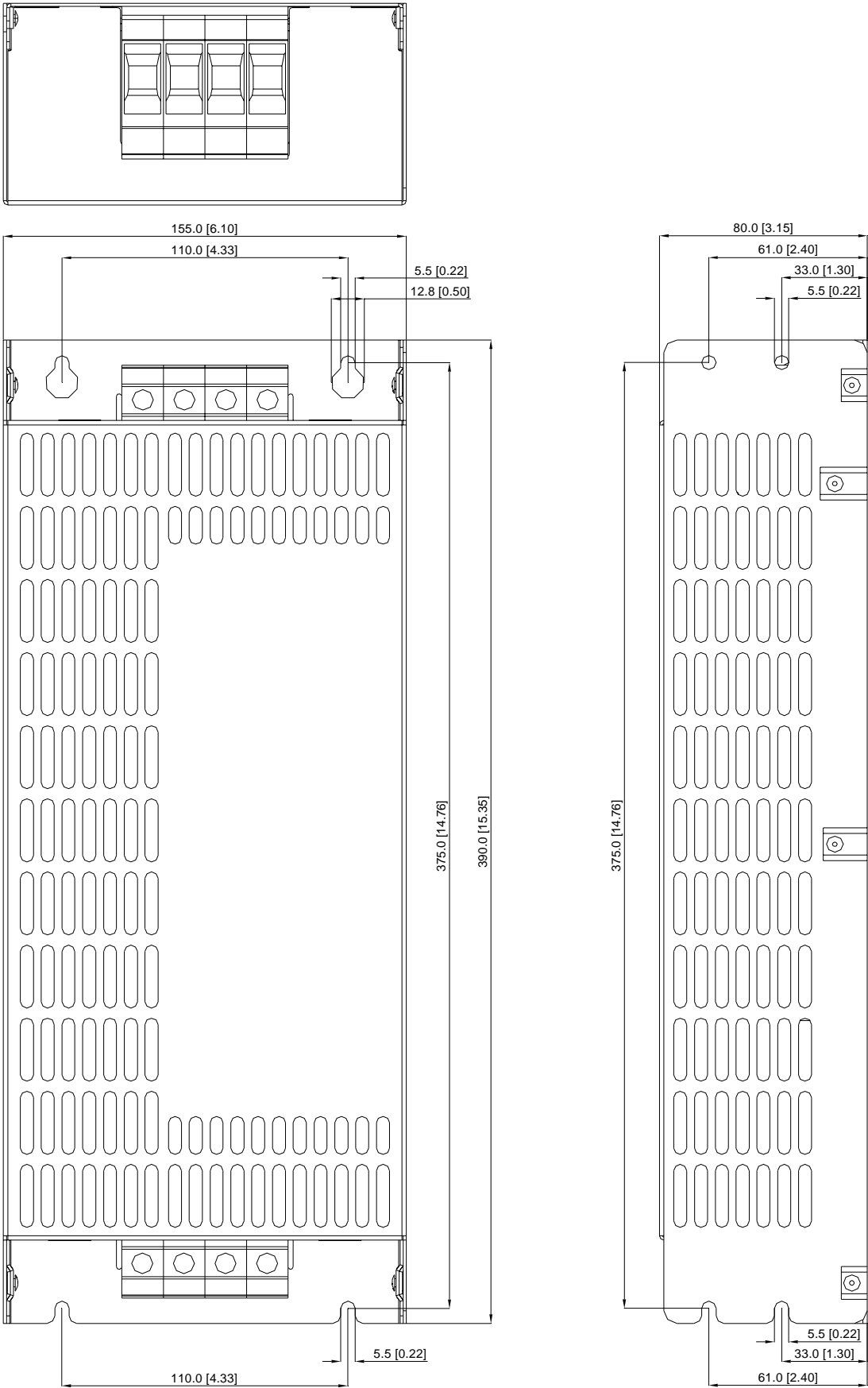

06 List of Parameters

Users can quickly look up the range and factory setting for each parameter, making it convenient to set parameter values on their own. Parameter values can be set, changed, or reset using the digital keypad (optional) or via communication ports.

NOTE

- 1)  Parameter setting can be adjusted during operation.
- 2) For thorough parameter descriptions, please refer to 07 Detailed Descriptions of Parameters.

00 Display Parameters

Parameter codes	Parameter names	Setting range	Factory Setting
00-00	ID code for the power regenerative unit model	0: 230V, 7.5kW 1: 460V, 7.5Kw 2: 230V, 11kW 3: 460V, 11kW 4: 230V, 15kW 5: 460V, 15kW 6: 230V, 18.5kW 7: 460V, 18.5kW 8: 230V, 22kW 9: 460V, 22kW 10: 230V, 30kW 11: 460V, 30kW 12: 230V, 37kW 13: 460V, 37kW 15: 460V, 45kW 17: 460V, 55kW	Read-only
00-01	Current rating of the power regenerative unit	0: 20A 1: 10.5A 2: 32A 3: 17A 4: 38A 5: 20A 6: 49A 7: 25A 8: 60A 9: 32A 10: 80A 11: 43A 12: 100A	Read-only

Parameter codes	Parameter names	Setting range	Factory Setting
		13: 49A 15: 60A 17: 75A	
00-02	Software version	Read-only	Read-only
00-03	Displays input current of Power Regenerative Unit (A)	Read-only	Read-only
00-04	Displays mains frequency (Hz)	Read-only	Read-only
00-05	Displays DC voltage (V)	Read-only	Read-only
00-06	Displays power (kW)	-300.0 ~ 300.0	Read-only
00-07	Reserved		
00-08	Reserved		
00-09	Displays the lower value of kilowatt hours (kWh) regenerated by REG2000	0.0 ~ 999.9	Read-only
00-10	Displays the higher value of kilowatt hours (kWh) regenerated by REG2000	0 ~ 9999	Read-only
00-11	Displays the highest ambient temperature (°C)	Read-only	Read-only
00-12	Displays the highest IGBT temperature (°C)	Read-only	Read-only
00-13	Displays internal temperature (°C)	Read-only	Read-only
00-14	Displays power module's temperature (°C)	Read-only	Read-only
00-15	Displays the ON/OFF status of digital input	Read-only	Read-only
00-16	Displays the ON/OFF status of digital output	Read-only	Read-only
00-17	DC voltage during a malfunction (V)	Read-only	Read-only
00-18	Mains frequency during a malfunction (Hz)	Read-only	Read-only
00-19	Current during a malfunction (A)	Read-only	Read-only
00-20	Most recent error log	0: no error records	0
00-21	Second most recent error log	3: ocn overcurrent during operation	0
00-22	Third most recent error log	6: ocs overcurrent between operations	0
00-23	Fourth most recent error log	9: ovn overvoltage during operation	0

Parameter codes	Parameter names	Setting range	Factory Setting
00-24	Fifth most recent error log	10: ovs overvoltage between operations	0
00-25	Sixth most recent error log	13: LVn low voltage during operation	0
		15: OrP open-phase in input	
		16:oH1 power module overheated	
		17: oH2 internal ambient temperature overheated	
		18 : tHo1 power module overheated protection circuit error	
		19 : tHo2 Internal ambient temperature overheated protection circuit error	
		21: oL overload	
		30: cF1 memory write error	
		31: cF2 memory read error	
		33: cd1 U-phase current detection error	
		34: cd2 V-phase current detection error	
		35: cd3 W-phase current detection error	
		37: Hd1 oc current detection error	
		38: Hd2 ov voltage detection error	
		42: 5VF 5V in the control board error (FW v1.02)	
		43: RYF relay error (FW v1.02)	
		49: EF external signal input error	
		52: Pcod password incorrect	
		54: cE1 communication error (warn)	
		55: cE2 communication error (warn)	
		56: cE3 communication error (warn)	
		57: cE4 communication error (warn)	
		58: cE10 communication timeout (warn)	
		66: PLE phase-locking error	
00-26	Low word in electricity bill	Read-only	Read-only
00-27	High word in electricity bill	Read-only	Read-only
00-28	Displays input AC voltage (V)	0~6553.5	Read-only

01 Basic Parameters

Parameter codes	Parameter names	Setting range	Factory Setting
01-00	Reset parameters	0: no function 1: parameter cannot be written 10: parameter reset	0
↗01-01	Select startup display	0: mains frequency 1: DC BUS voltage 2: input current	0
↗01-02	Enter parameter protection password	1~9998,10000~65535 0-2: number of incorrect passwords entered	0
↗01-03	Set parameter protection password	1~9998,10000~65535 0: password not set or password entered successfully in 01-02 1: parameters locked	0
↗01-04	Set source of operation command	1: operate from external terminals 2: input from RS-485 devices or digital keypad (KPC-CE01/ KPC-CC01)	1
01-05	Reserved		
01-06	Reserved		
01-07	Reserved		
01-08	Set operating point DC voltage (offset value)	230V : 30~100V 460V : 60~200V	40 80
01-09	Reserved		
↗01-10	DC voltage control P gain	0~1000%	100
↗01-11	DC voltage control I gain	0~1000%	100
↗01-12	DC voltage control bandwidth	1~100Hz	40
01-13	Reserved		
↗01-14	Select multi-function display	0: display DC voltage (v)	0
		1: display mains frequency (H)	
		2: display input current (A)	
		3: display input AC voltage (E)	
		4: display voltage between R and S (r)	
		5: display voltage between S and T (S)	
		6: display voltage between T and R (t)	
		7: display power (P)	
8: display current limit (p)			

02 Digital Input/Output Parameters

Parameter codes	Parameter names	Setting range	Factory Setting
02-00	Multi-function input command 1 (MI1)	0: no function	1
02-01	Multi-function input command 2 (MI2)	1: Automatic mode	0
02-02	Multi-function input command 3 (MI3)	2: Reserved	3
02-03	Multi-function input command 4 (MI4)	3: EF	4
02-04	Multi-function input command 5 (MI5)	4: RESET	5
		5: Parallel mode	
		6: no function	
↗02-05	Digital input response time	0.001 - 30.000s	0.005
↗02-06	Digital input working direction	0~65535	0
↗02-07	Multi-function output 1 (Relay1)	0: no function	4
↗02-08	Multi-function output 2 (MO1)	1: operation indicator	3
↗02-09	Multi-function output 3 (MO2)	2: no function	0
		3: preparation complete	
		4: error indicator	
		5: no function	
		6: warning indicator	
		7: no function	
↗02-10	Multi-function output direction	0~65535	0

03 Special Protection Parameters

Parameter codes	Parameter names	Setting range	Factory Setting
↗03-00	Low voltage level	230V models:160.0 - 220.0Vdc 460V models:320.0 - 440.0Vdc	180 360
↗03-01	Current limit	0~150%	150
↗03-02	Reserved		
↗03-03	Reserved		
↗03-04	Phase-locking frequency deviation time	0 - 1000ms	150
↗03-05	Reserved		
↗03-06	Reserved		
↗03-07	Number of error restarts	0~10	0
↗03-08	Time until error restart count resets	0.1 - 6000.0s	60.0
↗03-09	Cooling fan control mode	0: fan continues to run 1: runs for 1 minute after shut down and then stops 2: runs/stops as the Power Regenerative Unit runs/stops 3: runs according to the temperature of the power module 4: remains off	3
03-10	Reserved		
03-11	Reserved		
↗03-12	Clears the memory of regenerated energy	0: no function 1: clear	0
↗03-13	Electricity rate	0 - 6553.5 dollars/kWh	3.0

04 Communication Parameters

Parameter codes	Parameter names	Setting range	Factory Setting
↗04-00	Communication address	1~254	1
↗04-01	COM1 transmission speed	4.8~115.2Kbps	9.6
↗04-02	COM1 transmission error handling	0: gives warning but continues operating 1: gives warning and stops operation 2: reserved 3: no actions and no display	3
↗04-03	COM1 timeout detection	0.0 - 100.0s	0
↗04-04	COM1 communication format	0: 7N1 (ASCII) 1: 7N2 (ASCII) 2: 7E1 (ASCII) 3: 7O1 (ASCII) 4: 7E2 (ASCII) 5: 7O2 (ASCII) 6: 8N1 (ASCII) 7: 8N2 (ASCII) 8: 8E1 (ASCII) 9: 8O1 (ASCII) 10: 8E2 (ASCII) 11: 8O2 (ASCII) 12: 8N1 (RTU) 13: 8N2 (RTU) 14: 8E1 (RTU) 15: 8O1 (RTU) 16: 8E2 (RTU) 17: 8O2 (RTU)	1
↗04-05	Communication response time delay	0.0~200.0ms	2
04-06 ~ 04-38	Reserved		

05 Application Parameters

Parameter codes	Parameter names	Setting range	Factory Setting
↗05-00	DC voltage filtering time	0.000~65.535	0.000
↗05-01	Mains frequency filtering time	0.000~65.535	0.000
05-02 ~ 05-20	Reserved		

07 Description of Parameter Settings

00 Display Parameters

↗ represents parameter settings that can be adjusted during operation

00-00 ID code for the Power Regenerative Unit model

00-01 Current rating of the Power Regenerative Unit

Factory setting: read-only

Display by model Read-only



Parameter 00-00 determines the capacity of the Power Regenerative Unit and is already set at this parameter when shipped from the factory. Also, the current value in the readable parameter (00-01) is the rated current for that model. Parameter 00-00 corresponds to the current displayed in parameter 00-01.

REG2000 Model code table																
Input voltage	230V							460V								
Model code	0	2	4	6	8	10	12	1	3	5	7	9	11	13	15	17
Suitable Power Regenerative Unit capacity (kW)	7.5	11	15	18.5	22	30	37	7.5	11	15	18.5	22	30	37	45	55
Rated input current (A)	20	32	38	49	60	80	100	10.5	17	20	25	32	43	49	60	75

00-02 Software version

Factory setting: #.##

Read-only (display according to shipped version)

00-03 Display input current of the Power Regenerative Unit(A)

00-04 Displays mains frequency (Hz) (cable frequency)

Factory setting: #.##

Read-only

00-05 Display DC voltage (V)

Factory setting: #.#

Read-only



00-06 Displays power (kW)

Factory setting: #.#

-300.0 ~ 300.0

00-07 Reserved

00-08 Reserved

00-09	Displays the lower value of kilowatt hours (kWh) regenerated by REG2000	Factory setting: ###.#
	0.0~999.9	
00-10	Displays the higher value of kilowatt hours (kWh) regenerated by REG2000	Factory setting: #####
	0~9999	
	When Pr.03-12 =1, Pr.00-09 and Pr.00-10 will be cleaned to be 0 and Pr03-12 will be back to 0.	
	When the setting of Pr00-09 and Pr00-10 are done, the REG will start to run and the counting will start.	
	Display Pr00-10*1000 + Pr00-09.	
00-11	Displays the highest ambient temperature (°C)	
00-12	Displays the highest IGBT temperature (°C)	Factory setting: ##.#
	Read-only	
00-13	Displays internal temperature (°C)	
00-14	Displays power module's temperature (°C)	Factory setting: ##.#
	Read-only	
00-15	Displays the ON/OFF status of digital input	
00-16	Displays the ON/OFF status of digital output	Factory setting: ###
	Read-only	
00-17	DC voltage during a malfunction (V)	Factory setting: ##.#
	Read-only	
00-18	Mains frequency during a malfunction (Hz)	
00-19	Current during a malfunction (A)	Factory setting: #.##
	Read-only	
00-20	Most recent error log	
00-21	Second most recent error log	
00-22	Third most recent error log	
00-23	Fourth most recent error log	
00-24	Fifth most recent error log	
00-25	Sixth most recent error log	Factory setting: 0

Settings



- 0: no error records
- 3: ocn over current during operation
- 6: ocs over current between operations
- 9: ovn overvoltage during operation
- 10: ovs overvoltage between operations
- 13: LVn low voltage during operation
- 15: OrP open-phase in input
- 16: oH1 power module overheated
- 17: oH2 internal ambient temperature overheated
- 18: tHo1 power module overheated protection circuit error
- 19: tHo2 internal ambient temperature overheated protection circuit error
- 21: oL overload
- 30: cF1 memory write error
- 31: cF2 memory read error
- 33: cd1 U-phase current detection error
- 34: cd2 V-phase current detection error
- 37: Hd1 oc current detection error
- 38: Hd2 ov voltage detection error
- 42: 5VF 5V in the control board error (FW v1.02)
- 43: RYF relay error (FW v1.02)
- 49: EF external signal input error
- 52: Pcod password incorrect
- 54: cE1 communication error (warn)
- 55: cE2 communication error (warn)
- 56: cE3 communication error (warn)
- 57: cE4 communication error (warn)
- 58: cE10 communication timeout (warn)
- 66: PLE phase-locking error

 PLE and Orp errors are only recorded and deemed as a fault in power regeneration status, otherwise they will be warnings in Standby and Stop status.

 OH1 Level



Model	Default
REG075A23A	100
REG110A23A	110
REG150A23A	100
REG185A23A	100
REG220A23A	100
REG300A23A	95
REG370A23A	105

Model	Default
REG075A43A	100
REG110A43A	105
REG150A43A	110
REG185A43A	100
REG220A43A	90
REG300A43A	90
REG370A43A	95
REG450A43A	115
REG550A43A	115

 00-26 Low word in electricity bill
 00-27 High word in electricity bill

Factory setting: ###

Settings Read-only

-  When Pr.03-12 =1, Pr.00-09 and Pr.00-10 will be cleaned to be 0 and Pr03-12 will be back to 0.
-  Display the dollar amount saved on electricity expense. The setting of the related parameters are shown below.

The kw/hr regenerated (Pr 00-09 ~ 00-10) x electricity expense (Pr03-13).
The display mode is Pr00-27*1000 + Pr00-26.

00-28 Displays input AC voltage (V)

Factory setting: ##.#

Settings 0~6553.5

01 Basic Parameters

↗ represents

parameter settings that can be adjusted during operation

01-00 Reset parameters

Factory setting:0

Settings 0: no function
1: parameter cannot be written
10: parameter reset

 When set to "1", only parameters 01-00 to 01-03 can be adjusted, the other parameters will be read-only; in combination with the password parameters, this can prevent the parameters from being altered unintentionally by mistake.

 To restore the parameters to factory settings, just set this parameter to 10. If a password is set, it must first be entered before the settings can be restored, and the password will be cleared at the same time.

↗ **01-01** Select startup display

Factory setting: 0

Settings 0: mains frequency
1: DC voltage
2: input current

↗ **01-02** Enter parameter protection password

Factory setting: 0

Settings 1~9998, 10000~65535
Display 0-2: number of incorrect passwords entered
value

 Enter the password set in parameter 01-03 into parameter 01-02, and all password protected parameters will be unlocked.

 After setting this parameter, write down the setting to avoid inconveniences in the future.

 The purpose of using parameters 01-02 and 01-03 is to prevent non-technicians from unintentionally altering other parameters.

 If the password is lost or forgotten, it can be reset by entering 9999 and pressing the "ENTER" key, enter 9999 and press "ENTER" again (this sequence must be completed within 10 seconds, otherwise please do it again). This will also restore previously altered parameter settings back to the factory setting.

↗ **01-03** Enter parameter protection password

Factory setting:0

Settings 1~9998, 10000~65535
Display 0: password not set or password entered successfully in 01-02
value
1: parameters locked

 This parameter sets password protection, which can be entered directly the first time. After the

password is set, the parameter value will become 1, meaning password protection is enabled. To make changes to any parameter, first go to parameter 01-02 and enter the correct password. After unlocking the password protection, the parameter value for 01-02 will be set to 0, and all parameters will become adjustable.

- 📖 After password protection is enabled, all parameter values except for parameter 01-03 will display 0.
- 📖 Password protection can be turned off by unlocking the password protection in parameter 01-02 and setting this parameter to 0. Password protection will remain off after a system reboot.
- 📖 The password will otherwise remain active permanently. After turning on the system, if any parameters need to be changed, first unlock the password protection in parameter 01-02.
- 📖 How to reactivate password protection:

Method 1: Reenter the password in 01-03.

Method 2: Reboot the system and password protection will immediately be restored.

Method 3: Enter any value other than the password in 01-02.

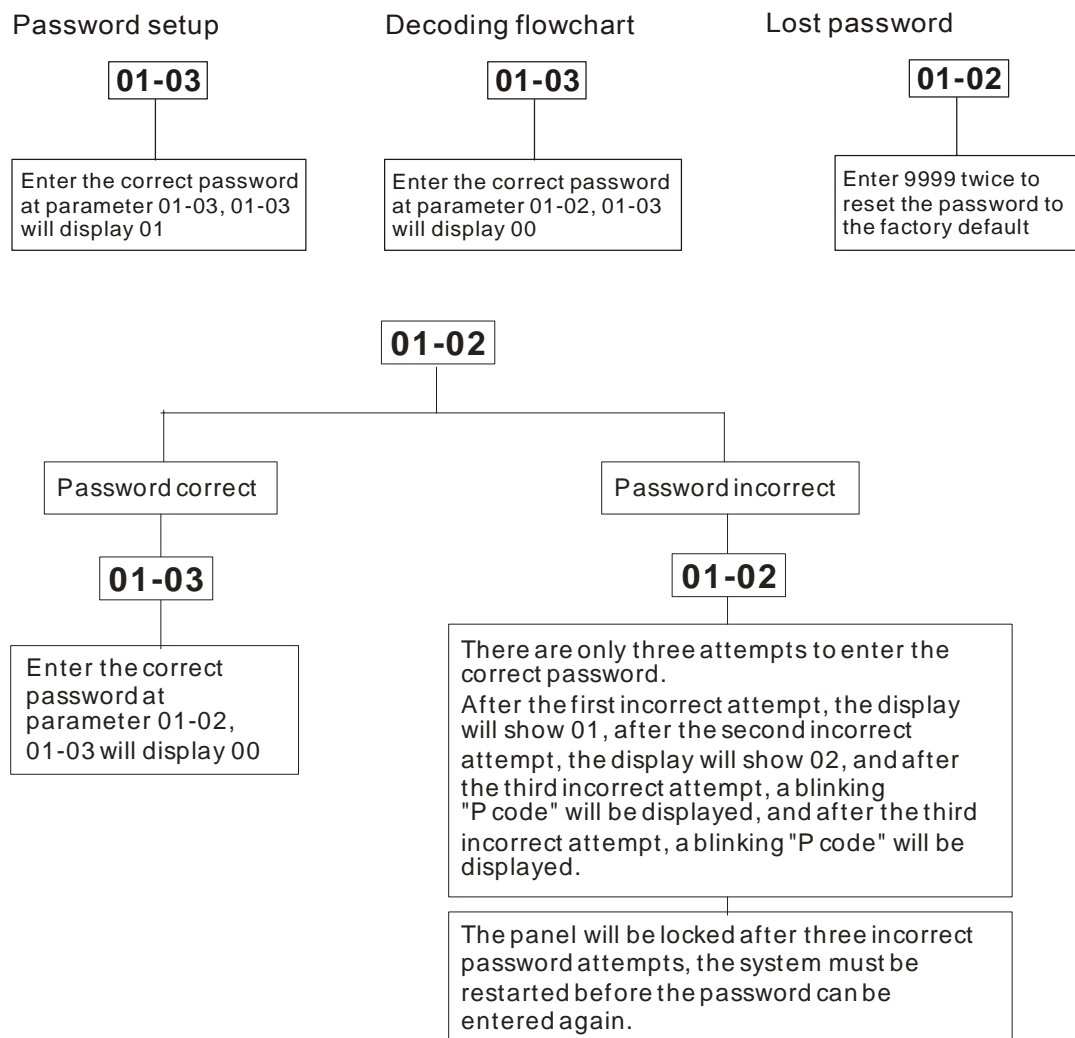

🚩 01-04 Set source of operation command

Factory setting: 1

Settings 1: operation commands controlled via external terminals

2: operation commands controlled through communication interface or the digital keypad (KPC-CC01)

- 📖 As the standard package does not contain the digital keypad upon shipping, users have to control

operation via external terminals. Please confirm that the wiring between multi-function input terminals is correct before using.

📖 To operate using the communication interface, a digital keypad KPC-CC01 or KPC-CE01 must be purchased before the source of operation command can be set to the communication interface.

01-05 Reserved

01-06 Reserved

01-07 Reserved

01-08 Set operating point DC voltage (offset value)

Settings 230V models: 30 - 100V

Factory setting:40

460V models: 60 - 200V

Factory setting:80

📖 The feedback activating voltage is set to the mains voltage (parameter 00-28) $[[* \sqrt{2}]]$ + parameter 01-08.

📖 Power regenerative unit will stop output when DC bus voltage < (DC bus voltage + parameter 01-08 – 10V).

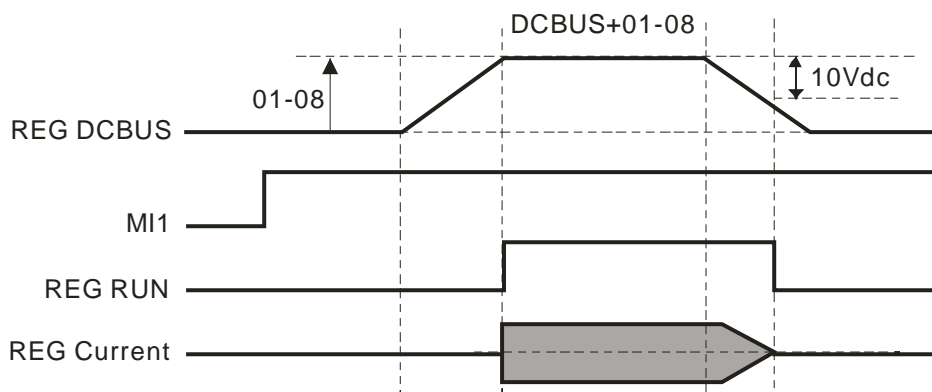

01-09 Reserved

↗ **01-10** DC voltage control P gain

↗ **01-11** DC voltage control I gain

Factory setting:100

Settings 0 - 1000%

📖 Pr01-10 is the parameter which decides the response rate of P function on DC BUS voltage bias.

📖 Take the greater gain, the response rate will be faster while the DC BUS voltage bias will become smaller. But if the gain is too big, there will be an oscillation.

📖 Take the smaller gain, the response rate will be slow while the DC BUS voltage bias will become larger. It is scaled to be 100% corresponding to the Kp value of auto-calculated DC BUS voltage controller bandwidth (Pr01-12).

📖 Pr01-11 is an integral controller to eliminate the error caused by the DC BUS voltage bias. The bigger the integral gain, the faster the response rate to respond to external disturbance. But the

smaller the integral gain, the slower the response rate to respond to the external disturbance. The oscillation is easy to occur. It is scaled to be 100% corresponding to the Ki value of auto-calculated DC BUS voltage controller bandwidth (Pr01-12).

↗ 01-12 DC voltage control bandwidth

Factory setting:40

Settings 1 - 100Hz

📖 This parameter controls the DC voltage response speed; the higher the value, the faster the response.

01-13 Reserved

↗ 01-14 Select multi-function display

Factory setting:0

Settings

- 0: display DC voltage (v)
- 1: display mains frequency (H)
- 2: display input current (A)
- 3: display input AC voltage (E)
- 4: display voltage between R and S (r)
- 5: display voltage between S and T (S)
- 6: display voltage between T and R (t)
- 7: display power (P)
- 8: display current limit (p)

02 Input and Output Parameters

✓ represents parameter settings that can be adjusted during operation

02-00	Multi-function input terminal 1 (MI1)	Factory setting:1
02-01	Multi-function input terminal 2 (MI2)	Factory setting:0
02-02	Multi-function input terminal 3 (MI3)	Factory setting:3
02-03	Multi-function input terminal 4 (MI4)	Factory setting:4
02-04	Multi-function input terminal 5 (MI5)	Factory setting:5

Settings 0: no function
 1: Automatic mode
 2: Reserved
 3: EF
 4: RESET
 5: Parallel mode
 6: no function

📖 This parameter can be planned and adjusted by the user to include necessary external terminal input functions as required.

List of functions

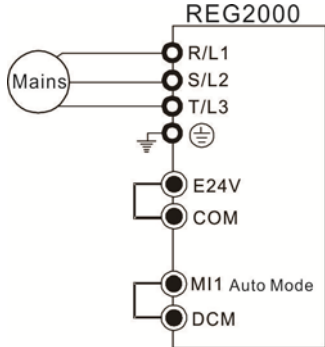
Setting	Function	Description
0	no function	The output terminal does not have any function
1	automatic mode (the default terminal is MI1)	<p>This terminal setting only becomes effective when parameter 01-04 is set to 1 "controlled via external terminals"</p> <p>When the Auto mode is ON and when the Power Regenerative Unit detects DC bus voltage reaches the setting of Pr01-08, the DC bus voltage will be regenerated to electrical grid.</p> <p>The default wiring between multi-function input terminals is as below. Please check the wiring is correct before using. Please refer to 04 Wiring for more details of wiring about auto mode.</p> 

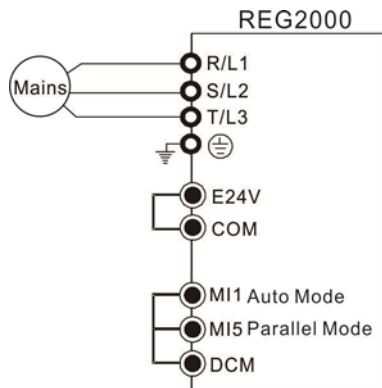
Setting	Function	Description
2	Reserved	The output terminal is reserved
3	EF	External failure input terminal
4	RESET	Only this terminal function can reset the Power Regenerative Unit after eliminating a failure
5	Parallel mode (the default terminal is MI5)	<p>This terminal setting only becomes effective when parameter 01-04 is set to 1 "controlled via external terminals"</p> <p>Working under parallel mode, each power regenerative unit will reduce its current limit to 80% automatically.</p> <p>The default wiring between multi-function input terminals of each power regenerative unit is as below. Please check the wiring is correct before using. Please refer to 04 Wiring for more details of wiring about parallel mode.</p> 
6	no function	The output terminal does not have any function

02-05 Digital input response time

Factory setting:0.005

Settings 0.001 - 30.000s

This parameter adds a delay and confirm process to digital input terminal signals, the delay time is the confirmation time. This can prevent unknown interference from causing the digital input terminals (MI1 - 5) to malfunction (except counting inputs). This parameter can significantly improve these situations, but response time will be slightly delayed.

02-06 Digital Output Working Direction

Factory setting: 0

Settings 0 - 65535

This parameter sets the activation point for input signals, and the setting has no relation to the SINK/SOURCE status of the terminals.

bit 0 - bit 4 corresponds to MI1 - MI5, respectively.

Users can enter corresponding values by ways of communication, to alter the ON/OFF status of the terminals.

02-07 Multi-function output (Relay 1)

Factory setting:4

02-08 Multi-function output (MO1)

Factory setting:3

02-09 Multi-function output (MO2)

Factory setting: 0

Settings

0: no function

1: operation indicator

2: no function

3: (phase-locking complete) preparation complete

4: error indicator

5: no function

6: warning indicator

7: no function

 This parameter can be planned and adjusted by the user to include necessary external terminal output functions as required.

List of functions

Setting	Function	Description
0	no function	The output terminal does not have any function
1	Operation indicator	When the Power Regenerative Unit is in RUN status, the contacts will be in ON status.
2	no function	The output terminal does not have any function
3	(Phase-locking complete) preparation complete	The contacts will "ON" when the Power Regenerative Unit is not suffering from any errors and phase-locking is complete.
4	Error indicator	The contacts will " ON " when an error is detected by the Power Regenerative Unit.
5	no function	The output terminal does not have any function
6	Warning indicator	The contacts will " ON " when a warning is detected by the Power Regenerative Unit.
7	no function	The output terminal does not have any function

02-10 Multi-function output direction

Factory setting: 0

Settings 0~65535

 The setting of this function is binary, if a bit is set to 1, the multi-function output direction is reversed; e.g. when parameter 02-07 is set to 1 (operation indicator), if the bit is set to 0 or the forward output direction, Relay 1 will activate (ON) only when the Power Regenerative Unit is in operation, and when the Power Regenerative Unit is stopped Relay 1 will be OFF. In contrast, if the bit is set to 1 or the reverse output direction, Relay 1 will be OFF when in operation, and ON when stopped.

Bit 2	Bit 1	Bit 0
MO2	MO1	RY1

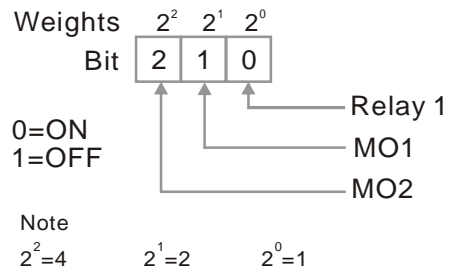

03 Special Protection Parameters

↗ represents parameter settings that can be adjusted during operation

↗ 03-00 Low voltage level

Factory setting:180.0/360.0

Settings 230V models:160.0~220.0V

460V models:320.0~440.0V

📖 This parameter sets the LV voltage level.

📖 When the voltage of the Power Regenerative Unit drops below the low voltage level, the parameter will send a warning.

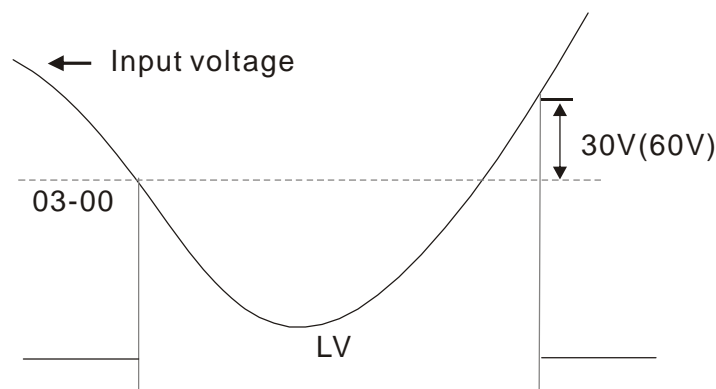

↗ 03-01 Current limit

Factory setting:150

Settings 0 - 150%

📖 This parameter limits the maximum current output of the Power Regenerative Unit.

03-02 Reserved

03-03 Reserved

03-05 Reserved

03-06 Reserved

↗ 03-04 Phase-locking frequency deviation time

Factory setting:150

Settings 0 - 1000ms

📖 When a frequency is detected to be < 47Hz or >63Hz and the duration is longer than the value set at Pr03-04, a PLE phase-locking signal will be generated.

↗ 03-07 Number of error restarts

Factory setting:0

Settings 0 - 10

📖 After an error (acceptable error: only OC over current, OV overvoltage), the number of times the Power Regenerative Unit can automatically reset/restart may be set to 10 times. If this is set to 0, then the system will not automatically reset/restart after an error.

03-08 Time until error restart count resets

Factory setting:60.0

Settings 0.1 - 6000.0s

- When an error restart occurs, the Power Regenerative Unit will start a count down according to the setting of this parameter. If the count down reaches the set time before another error restart, then parameter 03-07 number of error restarts will reset to the initial value.

03-09 Cooling fan control mode

Factory setting:3

Settings 0: fan runs always

1: runs for 1 minute after stop and then stops

2: runs/stops as the Power Regenerative Unit runs/stops

3: runs according to the temperature of the power module

4: always off

- This parameter determines the cooling fan setting.
- If the parameter is set to 0, the cooling fan will start running as soon as the Power Regenerative Unit starts transmitting power.
- If the parameter is set to 1, the cooling fan will run when the Power Regenerative Unit runs and will stop 1 minute after the Power Regenerative Unit stops.
- If the parameter is set to 2, the cooling fan will run when the Power Regenerative Unit runs and will stop as soon as the Power Regenerative Unit stops.
- If the parameter is set to 3, the cooling fan will adjust its speed according to the temperature of the power module. When the temperature is high, the cooling fan starts running; the higher the temperature the faster it runs, and when temperature drops within the normal range(As shown in the table below), the cooling fan will stop.
- If the parameter is set to 4, the cooling fan will be always off.

Model	Operating temperature range of fans (RUN→STOP)
REG075A23A	50→40
REG110A23A	60→50
REG150A23A	50→40
REG185A23A	50→40
REG220A23A	50→40
REG300A23A	45→35
REG370A23A	65→55
REG075A43A	50→40
REG110A43A	55→45
REG150A43A	60→50
REG185A43A	50→40
REG220A43A	40→30
REG300A43A	40→30
REG370A43A	45→35
REG450A43A	65→55
REG550A43A	65→55

03-10 Reserved

03-11 Reserved

03-12 Clears the record of regenerated energy

Factory setting: 0

Settings 0: parameter reverted

1: clear

 Setting this parameter to 1 clears parameters 00-09 and 00-10 to 0, and this parameter reverts to 0.**03-13** Electricity rate

Factory setting:3.0

Settings 0 - 6553.5

 Set up calculation for local electricity bill. Unit: dollar/kw-hr

04 Communication Parameters

↗ represents parameter settings that can be adjusted during operation

When using the communication interface, the communication port definition is shown as in the diagram on the right.

We recommend using a Delta IFD6530 or IFD6500 as a communication converter to connect the power regenerative unit to a computer.

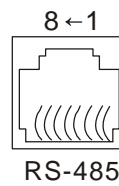

Modbus RS-485
 Pin 1~2, 7, 8: Reserved
 Pin 3, 6:GND
 Pin 4:SG-
 Pin 5:SG+

↗ 04-00 Communication address

Factory setting:1

Settings 1 - 254

📖 When the system uses the RS-485 serial communication interface to control or monitor, every Power Regenerative Unit must have their own communication address and every address in the network must be unique.

↗ 04-01 Communication transmission speed

Factory setting:9.6

Settings 4.8 - 115.2kbits/s

📖 This parameter sets the speed of transmission between the Power Regenerative Unit and computers.

↗ 04-02 Communication error handling

Factory setting:3

Settings 0: gives warning but continues operating
 1: gives warning and stops
 2: reserved
 3: no actions and no display

📖 This parameter determines how the Power Regenerative Unit handles a transmission timeout fault (such as a broken line) during communications.

↗ 04-03 Timeout detection

Factory setting:0.0

Settings 0.0 - 100.0s
 0.0: no detection

📖 This parameter sets the duration for a timeout during transmissions between communication ports and COM1.

↗ 04-04 Communication format

Factory setting:1

Settings 0: 7,N,1 for ASCII
 1: 7,N,2 for ASCII
 2: 7,E,1 for ASCII
 3: 7,O,1 for ASCII
 4: 7,E,2 for ASCII
 5: 7,O,2 for ASCII

- 6: 8,N,1 for ASCII
- 7: 8,N,2 for ASCII
- 8: 8,E,1 for ASCII
- 9: 8,O,1 for ASCII
- 10: 8,E,2 for ASCII
- 11: 8,O,2 for ASCII
- 12: 8,N,1 for RTU
- 13: 8,N,2 for RTU
- 14: 8,E,1 for RTU
- 15: 8,O,1 for RTU
- 16: 8,E,2 for RTU
- 17: 8,O,2 for RTU

 Computer control Computer Link

 When using the RS-485 serial communication interface, every Power Regenerative Unit must first have a communication address assigned in parameter 09-00. The computer will control the units based on their individual addresses.

 Communications protocol uses MODBUS ASCII (American Standard Code for Information Interchange) Mode: A byte is made by a combination of 2 ASCII codes. For example: the value 64 Hex, represented as "64" in ASCII, is a combination of "6" (36Hex) and "4" (34 Hex).

1. Character encoding

The communication protocol is hexadecimal, the ASCII codes denotes: "0"... "9", "A"... "F". Each hexadecimal character represents the corresponding ASCII code. For example:

Character	'0'	'1'	'2'	'3'	'4'	'5'	'6'	'7'
ASCII code	30H	31H	32H	33H	34H	35H	36H	37H
Character	'8'	'9'	'A'	'B'	'C'	'D'	'E'	'F'
ASCII code	38H	39H	41H	42H	43H	44H	45H	46H

2. Character structure

10-bit character frame (For ASCII)

(data format 7 , N , 2)

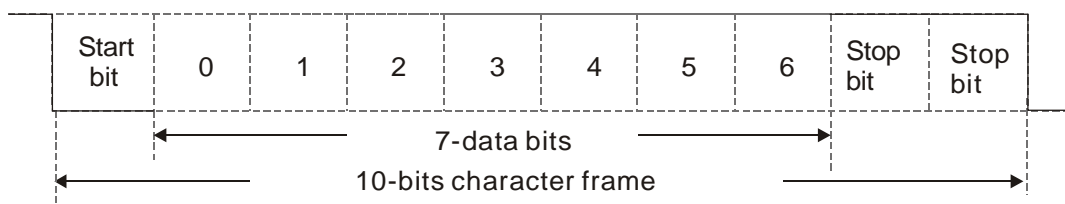

(data format 7 , E , 1)

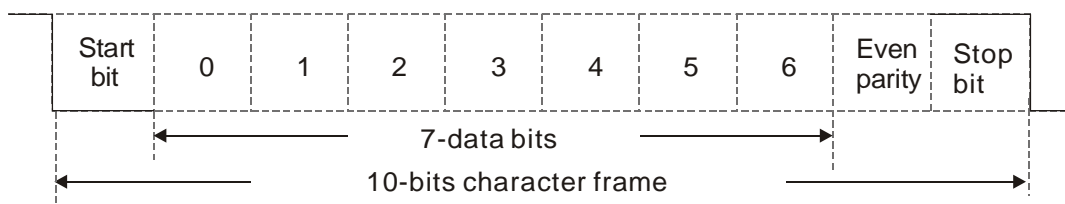

(data format 7 , O , 1)

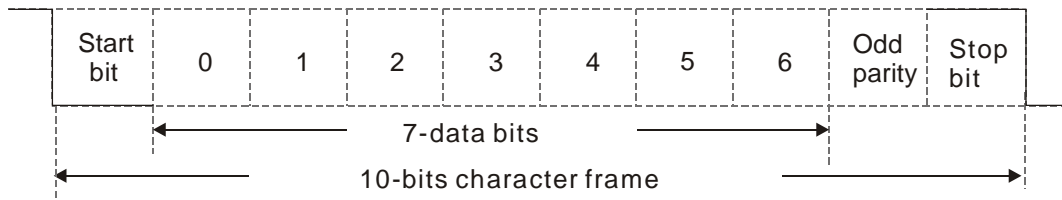

11-bit character frame (For RTU)

(data format 8 , N , 2)

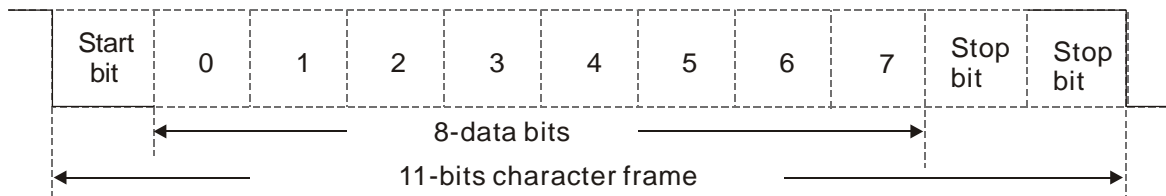

(data format 8 , E , 1)

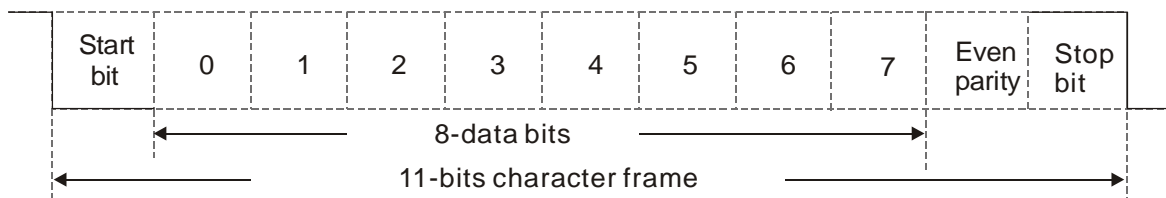

(data format 8 , O , 1)

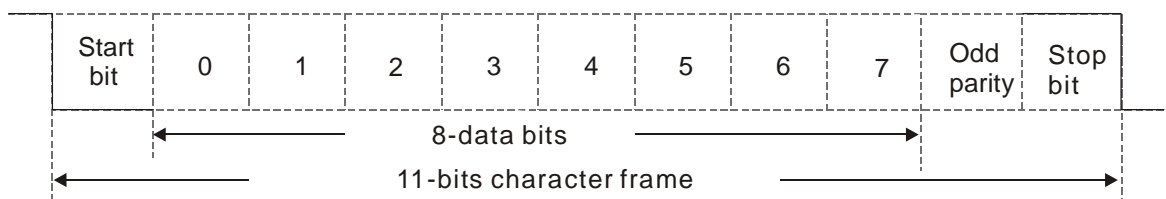

3. Communication data structure

Data format frame

ASCII mode:

STX	Start bit = ':' (3AH)
Address Hi	Communication address
Address Lo	8-bit addresses are a combination of 2 ASCII codes
Function Hi	Function code:
Function Lo	8-bit function codes are a combination of 2 ASCII codes
DATA (n-1)	Data character:
.....	n×8-bit data characters are combinations of 2n ASCII codes
DATA 0	n≤16, at most 32 ASCII codes (20 sets of data)
LRC CHK Hi	LRC check codes:
LRC CHK Lo	8-bit check codes are a combination of 2 ASCII codes
END Hi	End bit:
END Lo	END Hi = CR (0DH), END Lo = LF(0AH)

RTU mode:

START	Maintains no input signal for at least 10ms
Address	Communication address 8-bit binary address
Function	Function code: 8-bit binary address
DATA (n-1)	Data character:
.....	n x 8-bit data, n ≤ 16
DATA 0	
CRC CHK Low	CRC check codes: 16-bit CRC check codes are a combination of 2 8-bit binary codes
CRC CHK High	
END	Maintains no input signal for at least 10ms

Communication address (Address)

00H: broadcasts to all Power Regenerative Units

01H: targets the Power Regenerative Unit at address 01

0FH: targets the Power Regenerative Unit at address 15

10H: targets the Power Regenerative Unit at address 16, and so on..., to the maximum of 254 (FEH).

Function code and data character

03H: reads data from the register

06H: writes one set of data to the register

For example: codes to target Power Regenerative Unit 01H, read out 2 consecutive data characters in the register as shown below: starting from register address 2102H

ASCII mode:

Inquiry message string format:

STX	‘.’
Address	‘0’
	‘1’
Function	‘0’
	‘3’
Starting address	‘2’
	‘1’
	‘0’
	‘2’
Number of data (count by word)	‘0’
	‘0’
	‘0’
	‘2’
LRC Check	‘D’
	‘7’
END	CR
	LF

Response message string format:

STX	‘.’
Address	‘0’
	‘1’
Function	‘0’
	‘3’
Number of data (count by byte)	‘0’
	‘4’
Content of starting address 2102H	‘1’
	‘7’
	‘7’
	‘0’
Content of address 2103H	‘0’
	‘0’
	‘0’
	‘0’
LRC Check	‘7’
	‘1’
END	CR
	LF

RTU mode:

Inquiry message string format:

Address	01H
Function	03H
Starting data address	21H
	02H
Number of data (count by word)	00H
	02H
CRC CHK Low	6FH
CRC CHK High	F7H

Response message string format:

Address	01H
Function	03H
Number of data (count by byte)	04H
Content of data address 2102H	17H
	70H
Content of data address 2103H	00H
	00H
CRC CHK Low	FEH
CRC CHK High	5CH

Function code 06H: writes one set of data to the register (at most 20 sets of data can be written consecutively to the register at once)

For example: for Power Regenerative Unit01H, write 6000 (1770H) to the internal setting parameter 0100H.

ASCII mode:

Inquiry message string format:		Response message string format:	
STX	‘.’	STX	‘.’
Address	‘0’	Address	‘0’
	‘1’		‘1’
Function	‘0’	Function	‘0’
	‘6’		‘6’
Data address	‘0’	Data address	‘0’
	‘1’		‘1’
	‘0’		‘0’
	‘0’		‘0’
Data content	‘1’	Data content	‘1’
	‘7’		‘7’
	‘7’		‘7’
	‘0’		‘0’
LRC Check	‘7’	LRC Check	‘7’
	‘1’		‘1’
END	CR	END	CR
	LF		LF

RTU mode:

Inquiry message string format:		Response message string format:	
Address	01H	Address	01H
Function	06H	Function	06H
Data address	01H	Data address	01H
	00H		00H
Data content	17H	Data content	17H
	70H		70H
CRC CHK Low	86H	CRC CHK Low	86H
	CRC CHK High		22H

Command code: 10H, continuously writes multiple sets of data

For example, change the multispeed settings 04-00=50.00 (1388H), 04-01=40.00 (0FA0H) for the Power Regenerative Unit (address 01H)

ASCII mode:

Command message:		Response message:	
STX	‘.’	STX	‘.’
ADR 1	‘0’	ADR 1	‘0’
ADR 0	‘1’	ADR 0	‘1’
CMD 1	‘1’	CMD 1	‘1’
CMD 0	‘0’	CMD 0	‘0’
Data Start address	‘0’	Data address	‘0’
	‘5’		‘5’
	‘0’		‘0’
	‘0’		‘0’
Data amount (Word)	‘0’	Data amount (Word)	‘0’
	‘0’		‘0’
	‘0’		‘0’
	‘2’		‘2’

Command message:		Response message:	
Data amount (Byte)	'0'	LRC Check	'E'
	'4'		'8'
First set Data	'1'	END	CR
	'3'		LF
	'8'		
	'8'		
Second set Data	'0'		
	'F'		
	'A'		
LRC Check	'0'		
	'9'		
END	'A'		
	CR		
	LF		

RTU mode:

Command message:		Response message:	
ADR	01H	ADR	01H
CMD	10H	CMD 1	10H
Data	05H	Data	05H
Start address	00H	Start address	00H
Data amount (Word)	00H	Data amount (Word)	00H
Data amount (Byte)	02H	CRC Check Low	41H
	04	CRC Check High	04H
First set Data	13H 88H		
Second set Data	0FH A0H		
CRC Check Low	'9'		
CRC Check High	'A'		

Check code in ASCII mode (LRC Check)

Check code (LRC Check) is the sum from Address to Data Content. For example, the check code of the inquiry message in 3.3.1 above: 01H + 03H + 21H + 02H + 00H + 02H = 29H, and take the complement number of 2 = D7H.

Check code in RTU mode (CRC Check)

Check code starts from Address and ends at Data content. The calculation is shown below:

Step 1: set the 16-bit register (CRC register) = FFFFH.

Step 2: Exclusive OR the first 8-bit byte message and the low bit 16-bit CRC register, create Exclusive OR, and store the results in CRC register.

Step 3: shift 1 CRC register to the right, fill in 0 high bit position.

Step 4: check the shifted value, if it is 0, store the new value from step 3 to the CRC register, otherwise Exclusive OR A001H and the CRC register, and store the results to the CRC register.

Step 5: repeat steps 3 - 4, until all 8-bits are complete.

Step 6: repeat step 2 - step 5, take the message command from the next 8-bit, until all message commands are computed. Finally, the acquired value in the CRC register is the CRC check code. Please note the CRC check code must be alternate places within the message command check code.

The following is an example of computing the CRC check code using language C:

```

unsigned char* data ← // message command index
unsigned char length ← // length of message command
unsigned int crc_chk(unsigned char* data, unsigned char length)
{
  int j;
  unsigned int reg_crc=0Xffff;
  while(length--){
    reg_crc ^= *data++;
    for(j=0;j<8;j++){
      if(reg_crc & 0x01){ /* LSB(b0)=1 */
        reg_crc=(reg_crc>>1) ^ 0Xa001;
      }else{
        reg_crc=reg_crc >>1;
      }
    }
  }
}

return reg_crc; // final value returned to CRC register

```

4. Definition of parameter addresses in the communication protocol

Definition	Parameter address	Description of Function		
REG2000 parameters	GGnnH	GG stands for the parameter group and nn stands for the parameter number. For example: 04-01 is shown as 0401H.		
Command Write only	2000H	Bit2~0	0: no function 1: stop 2: start	
		Bit15~3	no function	
	2001H	no function		
	2002H	Bit0	1:E.F. ON	
		Bit1	1: reset command	
		Bit2	1: no function	
		Bit3~5	no function	
Status monitor Read only	2100H	Error code		
	2101H	Status of Drive		
		Bit 1~0	00: Reserved 01: Reserved 10: Reserved 11: Reserved	
		Bit 2	1: Reserved	
		Bit 4~3	00: Reserved 01: Reserved 10: Reserved 11: Reserved	
			Bit 5	1: Reserved
			Bit 6	Reserved
			Bit 7	1: Operation command controlled by external terminal
		Bit 8	Reserved	
		Bit 9	Reserved	
		Bit 10	Reserved	
		Bit 11	1: Parameters been locked	
		Bit 12	0: No regeneration 1: Regeneration	

Definition	Parameter address	Description of Function	
Status monitor Read only	2119H	Bit 13	1: Reg Running (include standby)
		Bit 15~14	Reserved
		Bit 1~0	0: stop 1: Set operating command, but DC BUS voltage not yet back to regulative operating voltage (Pr01-08) 3: In operation
		Bit 9~2	no function
		Bit10	1: operation commands from communication interface
		Bit11	1: parameters locked
		Bit12	Digital keypad copies the parameter functions
		Bit15~13	Reserved
	2102H	Mains frequency	
	2104H	Output current (AXX.XX)	
	2116H	Multi-function display (parameter 01-14)	
	2200H	Displays output current	
	2210H	ON/OFF status of digital input, see parameter 02-06	
2211H	ON/OFF status of digital output, see parameter 02-10		

5. Additional response in communication errors

If an error occurs when the Power Regenerative Unit is making communication connections, the Power Regenerative Unit will respond to the main control system with an error code and set the highest bit (bit7) to 1 (i.e. Function code AND 80H), to make the main control system aware of the error. A warning message CE-XX will also be shown on the keypad display of the Power Regenerative Unit, where XX is the error code. Refer to the error code definitions in communication errors.

For example:

ASCII mode:		RTU mode:	
STX	':'	Address	01H
Address	'0'	Function	86H
	'1'	Exception code	02H
Function	'8'	CRC CHK Low	C3H
	'6'	CRC CHK High	A1H
Exception code	'0'		
	'2'		
LRC CHK	'7'		
	'7'		
END	CR		
	LF		

Error code definitions:

Error code	Description
1	Data character value error: the value is too large and cannot be recognized by the Power Regenerative Unit.
2	Parameter address error: parameter address cannot be recognized by the Power Regenerative Unit.
3	Password locked: cannot edit the parameters
4	Parameter cannot be edited in operation
10	Transmission timeout

⚡ **04-05** Communication response time delay

Factory setting:2.0

Settings 0.0 - 200.0ms

In situations where the host machine has not completed the transition (transmission - reception), use this parameter to delay the response time of the Power Regenerative Unit.

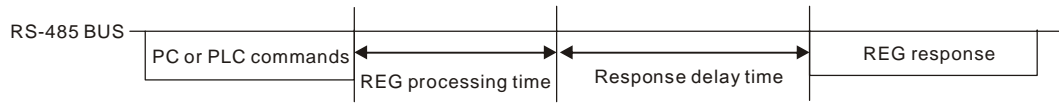

04-06 Reserved

05 Application Parameters

↗ represents parameter settings that can be adjusted during operation

↗ **05-00** DC voltage filtering time

Factory setting:0.000

Settings 0.000 - 65.535

📖 Pr05-00: Time of filter to adjust DC BUS voltage. The bigger the value, the better the filter result. But it might affect control performance, so it normally doesn't need adjustment.

↗ **05-01** Mains frequency filtering time

Factory setting:0.000

Settings 0.000 - 65.535

📖 Pr05-01: The filter time displayed by the frequency which normally doesn't need adjustment.

05-02

~

Reserved

05-20

08 Warnings and Fault Display Codes

This chapter contains information on the display function of the optional digital keypad (KPC-CC01/KPC-CE01), users who are not using the optional digital keypad can find out about error signals via the communication interface RS-485.

Warnings Display Codes

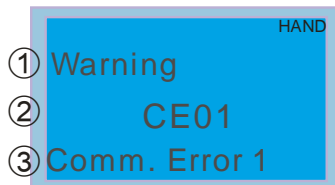

- ① Display error type
- ② Display error code (abbreviation)
This error code is the same as displayed on the digital controller (KPC-CE01)
- ③ Display error description

ID No.	LCM panel display	Description
1		Modbus function code error
2		Modbus data location error
3		Modbus data content error
4		Modbus driver processing error
5		Modbus transmission timeout
7		Keypad COPY function error warning
8		Keypad COPY function error warning 2

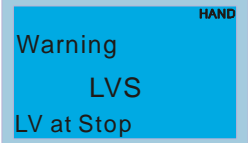
ID No.	LCM panel display	Description
14		While stopped, the power feedback unit detected voltages lower than the value set in parameter 03-00 on the high-voltage end of the internal DC voltage.

Fault Display Codes

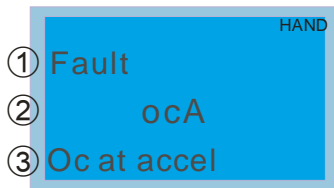

- ① Display error type
- ② Display error code (abbreviation)
This error code is the same as displayed on the digital controller (KPC-CE01)
- ③ Display error description

*: according to settings in parameters 00-20 to 00-25.

Setting	LCM panel display	Description
3		<p>Overcurrent during operation; input current exceeds 2.4 times the current rating of the power feedback unit.</p> <p>Solution</p> <ul style="list-style-type: none"> <input checked="" type="checkbox"/> Test wiring insulation <input checked="" type="checkbox"/> Raise DC voltage command (parameter 01-08) <input checked="" type="checkbox"/> Switch to a power feedback unit with a larger output current capacity.
6		<p>Overcurrent while stopped. Current detection hardware circuit error</p> <p>Solution</p> <p>Send for repair</p>
9		<p>While in operation, the power feedback unit detected overvoltage on the high-voltage end of the internal DC voltage. 230V: 425Vdc ; 460V : 850Vdc.</p> <p>Solution</p> <ul style="list-style-type: none"> <input checked="" type="checkbox"/> Check the power supply wiring between terminals R, S, T, for poor insulation or off-load line <input checked="" type="checkbox"/> Check whether the input voltage is within the voltage rating range of the power feedback unit, and the monitor for voltage surges. <input checked="" type="checkbox"/> Lower DC voltage command (parameter 01-08);or increase the current limit (parameter 03-01) <input checked="" type="checkbox"/> If there is a voltage surge, there may be a phase advancing capacitor switch in the same power supply system, causing abnormal rise in input voltage.
10		<p>Overvoltage while stopped. Voltage detection hardware circuit error</p> <p>Solution</p> <ul style="list-style-type: none"> <input checked="" type="checkbox"/> Check whether the input voltage is within the voltage rating range of the power feedback unit, and the monitor for voltage surges. <input checked="" type="checkbox"/> If there is a voltage surge, there may be a phase advancing capacitor switch in the same power supply system, causing abnormal rise in input voltage.
13		<p>While in operation, the power feedback unit detected voltages lower than the value set in parameter 03-00 on the high-voltage end of the internal DC voltage.</p> <p>Solution</p> <p>Check whether the power supply voltage is normal</p>

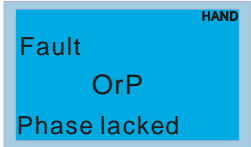
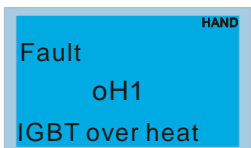
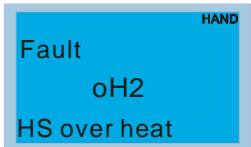
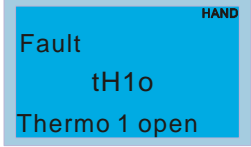
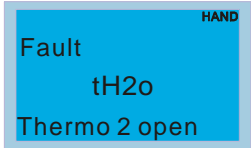
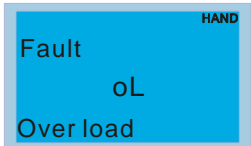
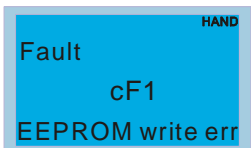
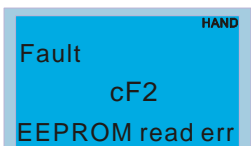
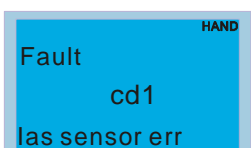
15	 <p>Fault OrP Phase lacked</p>	<p>Open-phase in input</p> <p>Solution</p> <p>Check whether the power supply cable is off-load</p>
16	 <p>Fault oH1 IGBT over heat</p>	<p>The power feedback unit detected a temperature higher than the safety level in the power module</p> <p>Solution</p> <ul style="list-style-type: none"> <input checked="" type="checkbox"/> Check whether the ambient temperature is too high <input checked="" type="checkbox"/> Check for foreign objects in the heat sink, and whether the fan is spinning <input checked="" type="checkbox"/> Check whether there is enough ventilation space near the power feedback unit
17	 <p>Fault oH2 HS over heat</p>	<p>A temperature higher than the safety level is detected within the power feedback unit</p> <p>Solution</p> <ul style="list-style-type: none"> <input checked="" type="checkbox"/> Check whether the ambient temperature is too high <input checked="" type="checkbox"/> Check for foreign objects in the heat sink, and whether the fan is spinning <input checked="" type="checkbox"/> Check whether there is enough ventilation space near the power feedback unit
18	 <p>Fault tH1o Thermo 1 open</p>	<p>Power module temperature detection circuit error</p> <p>Solution</p> <p>Send for repair</p>
19	 <p>Fault tH2o Thermo 2 open</p>	<p>Error in the internal temperature detection circuit of the power feedback unit</p> <p>Solution</p> <p>Send for repair</p>
21	 <p>Fault oL Over load</p>	<p>Input current exceeds the allowed current in the power feedback unit.</p> <p>Solution</p> <p>Increase the output capacity of the power feedback unit</p>
30	 <p>Fault cF1 EEPROM write err</p>	<p>Memory write error</p> <p>Solution</p> <p>Press the RESET key to restore the parameters to factory settings</p> <p>If this does not work, send for repair</p>
31	 <p>Fault cF2 EEPROM read err</p>	<p>Memory read error</p> <p>Solution</p> <p>Press the RESET key to restore the parameters to factory settings</p> <p>If this does not work, send for repair</p>
33	 <p>Fault cd1 Ias sensor err</p>	<p>R-phase current detection error</p> <p>Solution</p> <p>Restart and if the problem persists send for repair</p>

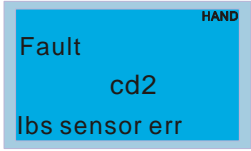
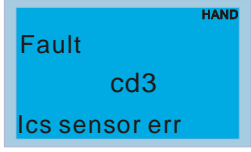
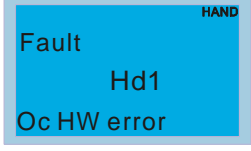
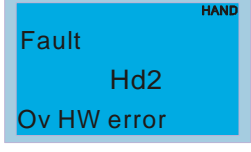
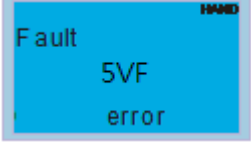
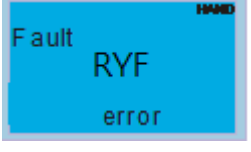
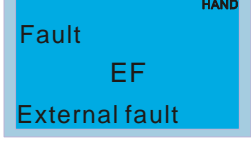
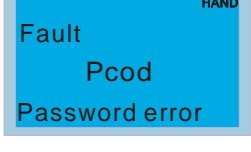
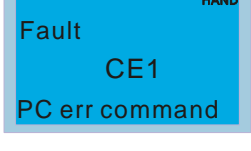
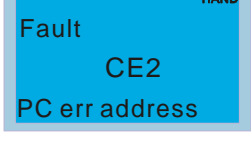
34		<p>S-phase current detection error</p> <p>Solution</p> <p>Restart and if the problem persists send for repair</p>
35		<p>T-phase current detection error</p> <p>Solution</p> <p>Restart and if the problem persists send for repair</p>
37		<p>OC protection hardware circuit error</p> <p>Solution</p> <p>Restart and if the problem persists send for repair</p>
38		<p>OV protection hardware circuit error</p> <p>Solution</p> <p>Restart and if the problem persists send for repair</p>
42		<p>5VF 5V in the control board error</p> <p>Solution</p> <p>Send back to vendor for repair</p>
43		<p>RYF relay error</p> <p>Solution</p> <p>Send back to vendor for repair</p>
49		<p>When the external EF terminals are closed, output from the power feedback unit stops</p> <p>Solution</p> <p>Remove the source of error and press the “RESET” key</p>
52		<p>Password entered incorrectly three consecutive times</p> <p>Solution</p> <ul style="list-style-type: none"> ● Refer to parameter settings 01-02 to 01-03 ● Reboot the system and enter the correct password
54		<p>Illegal communication command</p> <p>Solution</p> <p>Check whether communication commands are correct (communication commands must be 03, 06, 10, 63)</p>
55		<p>Illegal communication address (00H~254H)</p> <p>Solution</p> <p>Check whether the length of communication data is correct</p>

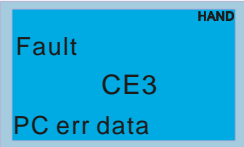
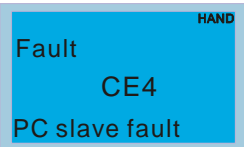
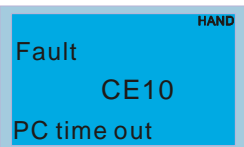
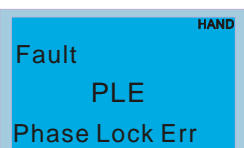
56		<p>Illegal communication data value</p> <p>Solution</p> <p>Check whether communication data value exceeds maximum / minimum values</p>
57		<p>Data written to read-only addresses</p> <p>Solution</p> <p>Check whether the communication address is correct</p>
58		<p>Modbus transmission timeout</p>
66		<p>Power frequency phase-lock error</p> <p>Solution</p> <p>Check whether the power supply cable is off-load</p>

09 Usage Recommendations and Troubleshooting

9-1 Regular Maintenance

9-2 Grease Problems

9-3 Lint Problems

9-4 Corrosion Problems

9-5 Dust Problems

9-6 Installation and Wiring Problems

9-7 Multi-function Input/Output Terminal Application Problems

The power feedback unit has various warnings and protections against errors such as over voltages, low voltages, or over current. Once an error occurs, the protections will activate, the power feedback unit will stop output, and the error contacts will be activated. Please refer to the error display from the power feedback unit and look up the corresponding causes and solutions. The error log is stored in the internal memory of the power feedback unit (can store the last 6 error messages), and can be read from the digital keypad or communication ports by accessing the parameters.

The power feedback unit is assembled from a large number of electronic components including IC, resistors, capacitors, transistors, and cooling fans and relays. These components are not built to last forever or be used forever; even under normal circumstances, they will eventually become error-prone if used past their life spans. Therefore periodic preventive maintenance needs to be implemented to identify defective and worn down parts, thus eliminating the causes of malfunctions in the power feedback unit at an early stage. At the same time, parts that have exceeded their product life should be replaced whenever possible to ensure safe operation.

Visual checks should be done regularly to monitor the operation of the power feedback unit, and make sure nothing unusual happens. Check whether the following situations occurred:



- ☑ After an error occurs, the error must be cleared for at least 5 seconds before the RESET key becomes effective.
- ☑ The power feedback unit must first be switched off for at least 5 minutes for $\leq 22\text{kW}$ model, and 10 minutes for $\geq 30\text{kW}$ model until the charging indicator turns off, and the DC voltage between terminals $\oplus \sim \ominus$ must be lower than 25V before the cover can be opened to begin maintenance operations.
- ☑ Only qualified operators shall work on maintenance or replace parts (watch, rings,

and other metal items should be taken off before operation, and only insulated tools should be used during operation).

- Never modify the power feedback unit in any way.
- The performance and the surrounding environment meet the standard specifications. No abnormal noise, vibration, or smell.

9-1 Regular Maintenance

For regular maintenance, first stop operation, then cut the power and take off the outer cover. Even after cutting off the power supply to the power feedback unit, charging voltages remaining in the filter capacitor will take some time to discharge. To avoid danger, operation must not start until the charging indicator goes off, and the voltage is confirmed with a voltmeter to be below the safety value ($\leq 25\text{Vdc}$).

Surrounding environment

Inspection item	Inspection method	Maintenance cycle		
		Daily	6 months	One year
Check the ambient temperature, humidity, vibration, and whether there is dust, gas, grease, water drops, etc.	Visual inspection and measuring instruments	○		
Are dangerous or abnormal objects such as tools placed in the surrounding area?	Visual inspection	○		

Voltage

Inspection item	Inspection method	Maintenance cycle		
		Daily	6 months	One year
Are the main circuit and control circuit voltages normal?	Measure with a multimeter	○		

Keyboard display panel

Inspection item	Inspection method	Maintenance cycle		
		Daily	6 months	One year
Are the displays clear?	Visual inspection	○		
Are there missing characters?	Visual inspection	○		

Mechanical parts

Inspection item	Inspection method	Maintenance cycle		
		Daily	6 months	One year
Are there abnormal sounds or vibrations?	Visual inspection, hearing	○	○	
Are any bolts (or other fastening pieces) loose?	Secure tightly	○	○	
Are any parts deformed or damaged?	Visual inspection	○	○	
Is there any discoloration due to excess heat?	Visual inspection	○	○	
Is there any dust or staining?	Visual inspection	○	○	

Main circuit

Inspection item	Inspection method	Maintenance cycle		
		Daily	6 months	One year
Are any bolts loose or missing?	Secure tightly	○		
Is the machine or insulator deformed, cracked, damaged, or discolored due to excess heat and aging?	Visual inspection		○	
Is there any dust or staining?	Visual inspection		○	

Main circuit - terminal, wiring

Inspection item	Inspection method	Maintenance cycle		
		Daily	6 months	One year
Are the terminals and copper plates deformed or discolored due to excess heat?	Visual inspection		○	
Are wire sheaths damaged or discolored?	Visual inspection		○	

Main circuit - terminal block

Inspection item	Inspection method	Maintenance cycle		
		Daily	6 months	One year
Is there any damage?	Visual inspection	○		

Main circuit - filter capacitor

Inspection item	Inspection method	Maintenance cycle		
		Daily	6 months	One year
Are there any leaking liquids, discoloration, cracks, or shell expansions?	Visual inspection	○		
Are the safety valves released? Are the valve bodies significantly expanded?	Visual inspection	○		
Measure electrostatic capacity as required		○		

Main circuit - resistor

Inspection item	Inspection method	Maintenance cycle		
		Daily	6 months	One year
Are there abnormal odors or cracks in the insulator due to excess heat?	Visual inspection, hearing	○		
Are there broken wires?	Visual inspection	○		
Are the connection joints damaged?	Measure the resistance with a multimeter	○		

Main circuit - transformer, reactor

Inspection item	Inspection method	Maintenance cycle		
		Daily	6 months	One year
Are there abnormal vibrating noises or odors?	Visual inspection, hearing	○		

Main circuit - electromagnetic contactor, relay

Inspection item	Inspection method	Maintenance cycle		
		Daily	6 months	One year
Is there a vibrating noise during operation?	Hearing	○		
Are the contacts well connected?	Visual inspection	○		

Control circuit - control printed circuit board, connector

Inspection item	Inspection method	Maintenance cycle		
		Daily	6 months	One year
Are there any loose screws or connectors?	Secure tightly		○	
Are there any abnormal odors or discoloration?	Olfactory perception, visual inspection		○	
Are there cracks, damages, deformations, or obvious corrosions?	Visual inspection		○	
Are there signs of leakage or deformation in the capacitors?	Visual inspection		○	

Cooling system - cooling fan

Inspection item	Inspection method	Maintenance cycle		
		Daily	6 months	One year
Do the fans run?	Hearing	○		
Are there abnormal sounds or vibrations?	Hearing, visual inspection, turn with hands. (Cut off power)		○	
Are any bolts loose?	Secure tightly		○	
Is there any discoloration due to excess heat?	Visual inspection		○	

Cooling system - ventilation duct

Inspection item	Inspection method	Maintenance cycle		
		Daily	6 months	One year
Are heat sinks or vents blocked or attached with abnormal objects?	Hearing		○	

 **NOTE**

Wipe the contaminated area clean with a chemically-neutral cleaning cloth. Clean with an electric dust cleaner.

9-2Grease Problems

Precautions for industries where grease pollution is more serious, typically machining, punching, or other processing industries:

- 1: grease accumulating on electrical components may cause components to short, resulting in explosions.
- 2: most are mildly corrosive, and will likely damage this product.

Recommended procedure: Users are recommended to install the power feedback unit in a dedicated cabinet, as far away from grease as possible, and clean it regularly to prevent the power feedback unit from being polluted and damaged by grease.

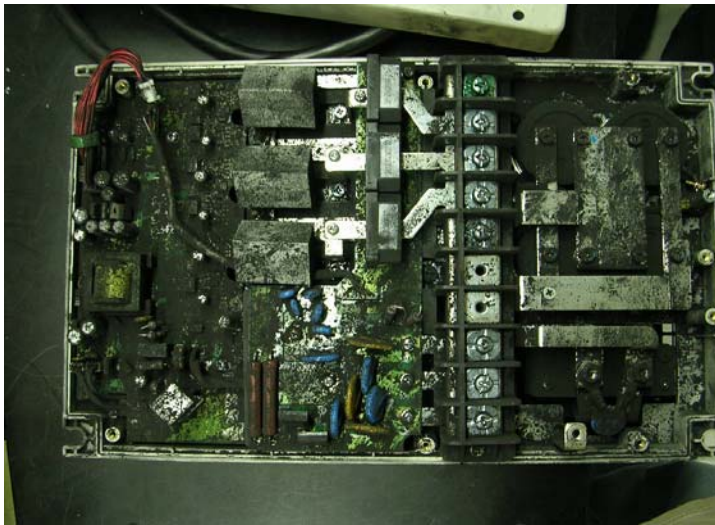

9-3 Lint Problems

Precautions for industries where lint pollution is more serious, typically textile industries:

1: lint often floats in the air and accumulates on fans and other devices, blocking the ventilation system in the power feedback unit, resulting in overheating.

2: textile factories are often humid, and lint easily collects water vapor, causing components on the circuit boards to short, in turn resulting in damage or explosions.

Recommended procedure: Users are recommended to install the power feedback unit in a dedicated cabinet, and clean it regularly to prevent lint from accumulating in the power feedback unit.



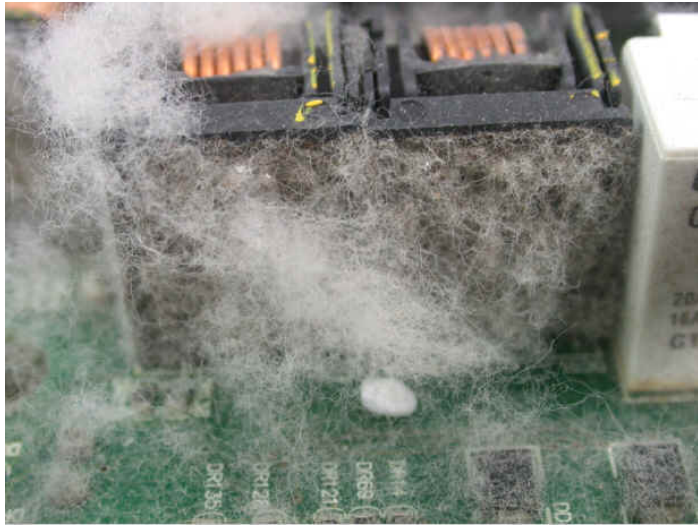

9-4 Corrosion Problems

Precautions for situations with corrosive materials, typically unknown liquids flowing into the power feedback unit: If the inner electrical components are corroded, it may lead to damage in the power feedback unit causing malfunctions or even explosions.

Recommended procedure: Users are recommended to install the power feedback unit in a dedicated cabinet, and by all means prevent liquids from flowing into the power feedback unit, and clean it regularly to prevent the power feedback unit from corrosion.

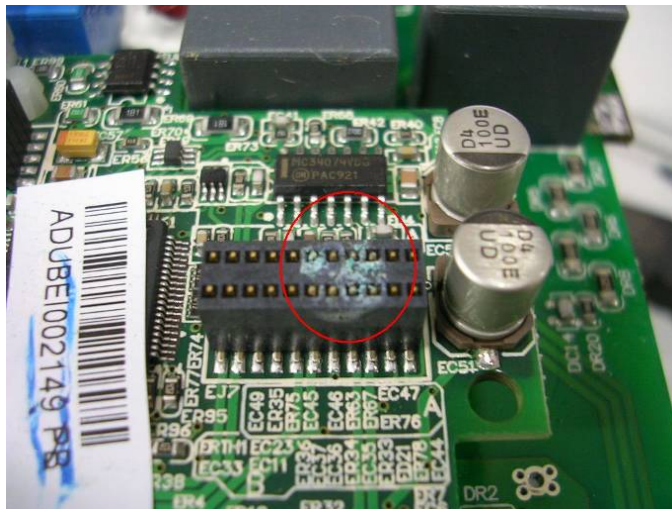
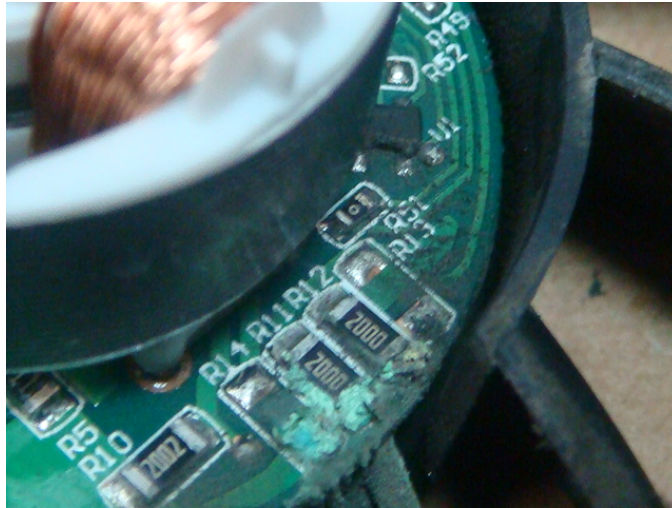

9-5 Dust Problems

Precautions for places where dust pollution is more serious, typically environments filled with dust such as stone processing plants, flour mills, or cement factories:

1: dust accumulating on the electrical components may cause overheating, thereby shortening the life of the product.

2: if the dust is conductive, they will very likely cause damage to the circuit and possibly explosions.

Recommended procedure: Users are recommended to install the power feedback unit in a dedicated cabinet with a dust cover, and clean the cabinet and air ducts regularly so that the power feedback unit may dissipate heat normally.

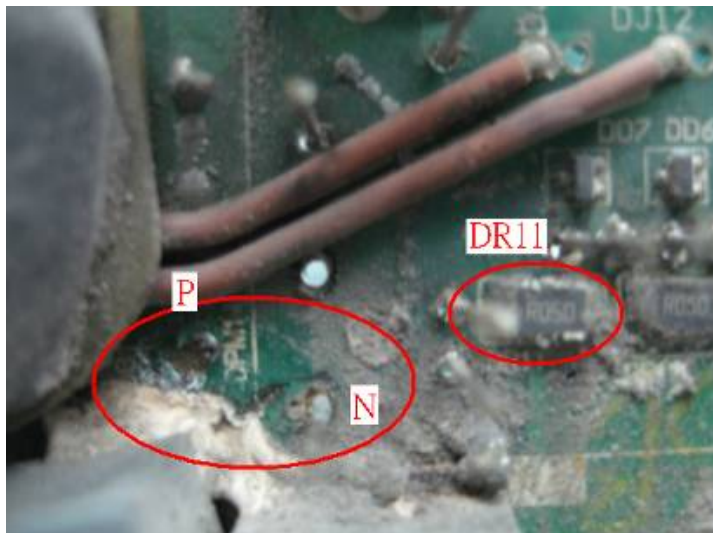
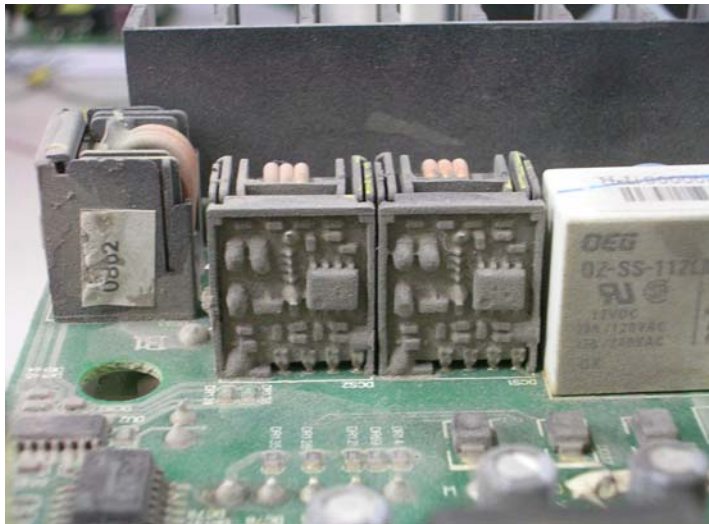

9-6 Installation and Wiring Problems

Precautions on wiring: these types of error usually occur due to improper wiring by the customer.

Effects on the product:

- (1) Loose wiring screws may lead to an increase in the contact resistance, causing arcing and damage to the power feedback unit.
- (2) Tampering with the circuits inside the power feedback unit by users may cause damage to relevant components.

Recommended procedure: Secure all wiring screws tightly when installing the power feedback unit! If the machine malfunctions, do not attempt to fix the problem yourself, please send the product to a specialized service center for repair!

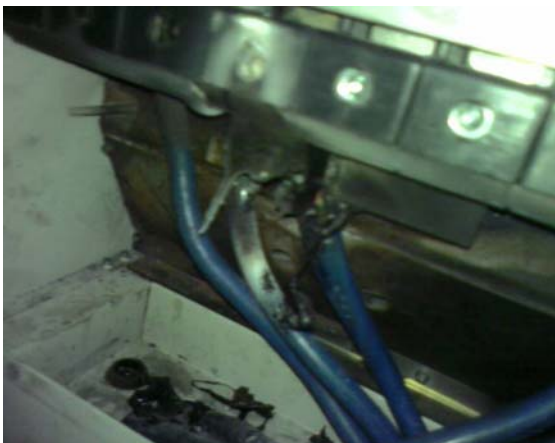
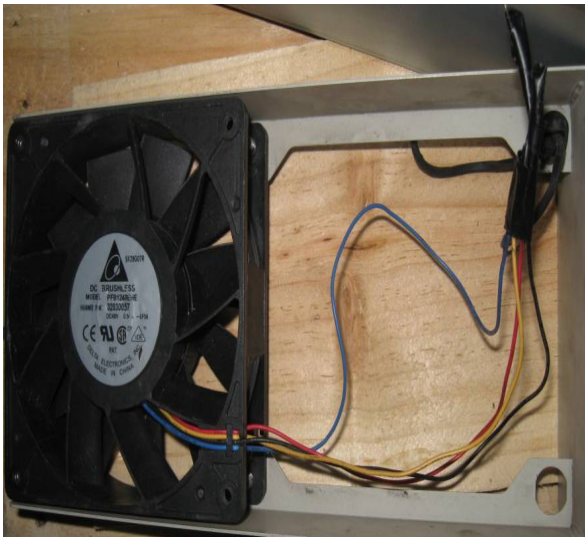
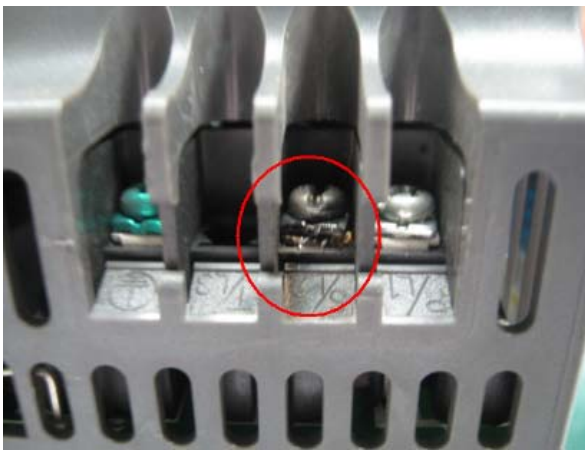

9-7 Multi-function Input/Output Terminal Application Problems

These types of error usually happen when the external I/O are abused; Precautions when using the external I/O functions: I/O related circuit components will be burned by the excessive energy and lose their function!

Recommended procedure: Refer to the voltage and current specifications in the manual when using these I/O contacts. Never exceed the specified limits!

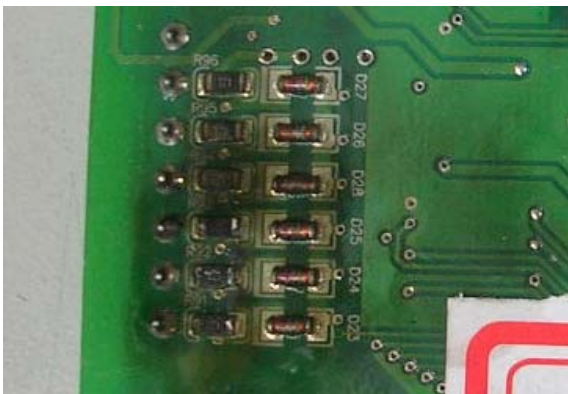
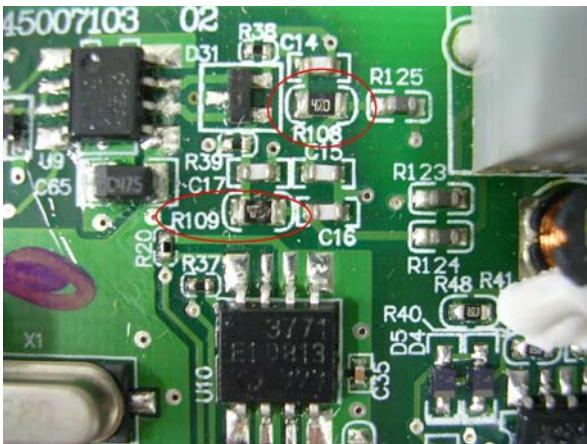
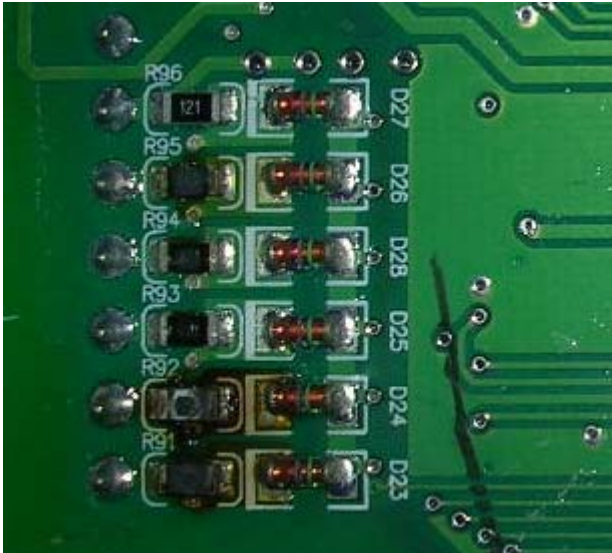

10 Power Regenerative Unit Selection

Delta offers four model selection methods of REG2000:

A. Make selection base on the specs of brake resistor

Suit for applications that require to perform rapid acceleration and deceleration, such as tapping drilling machines and lathes.

B. Make selection base on the overload ability of drive

Servo drive has higher overload ability than an inverter.

C. Make selection base on the load characteristics of applications

Calculate the regenerated power of the application using the application's system characteristics and specifications, especially for elevator and hoist application.

The three model selection methods are described in more detail below:

Model selection method 1 (base on the specs of brake resistor)

Take 220V as an example, if a 1500W 13Ω brake resistor is selected, with brake level set to 380V, then the total braking current would be $380V / 13\Omega = 29A$.

DC power equals AC power, i.e. $V_{dc} * I_{dc} = \sqrt{3} * V_{ac} * I_{ac}$

V_{ac} is AC voltage

I_{ac} is AC current

V_{dc} is DC voltage

I_{dc} is DC current

i.e. $I_{ac} = (V_{dc} * I_{dc}) / (\sqrt{3} * V_{ac}) = (380 * 29) / (\sqrt{3} * 220) = 28.9A$

The brake resistor's braking torque is 125% at 10%ED, and REG2000 is 150% at 10%ED, therefore selections can be made using REG2000's current at 150% in the following tables. In this example, REG075A23A-21 can be selected, as the current at 150% of 30A > total braking current of 28.9A

230V Series

Frames		A			B			C	
Model REG_ A23A-21		075	110	150	185	220	300	370	
Rated Power(kW)		7.5	11	15	18.5	22	30	37	
Mains	Input current(A)	20	32	38	49	60	80	100	
	Input current at 150%	30	48	57	73.5	90	120	150	

460V Series

Frames		A			B			C		
Model REG_ A43A-21		075	110	150	185	220	300	370	450	550
Rated Power(kW)		7.5	11	15	18.5	22	30	37	45	55
Mains	Input current(A)	10.5	17	20	25	32	43	49	60	75
	Input current at 150%	15.8	25.5	30	37.5	48	64.5	73.5	90	112.5

*Please contact Delta if the required current exceeds those listed above.

Model selection method 2 (base on the overload ability of drive)

Make the selection based on the overload ability of the drive. The table as below is an example that C2000 using with REG2000 when the condition is 10%ED and maximum regenerated work time during one cycle is 10sec. The overload ability of C2000 is 160% 3sec and 120% 60sec base on rated output current

Voltage	10%ED 10s		
	Drive	REG selection	
	kW	Model	Quantity
220V	0.7	REG075A23A	1
	1.5	REG075A23A	1
	2.2	REG075A23A	1
	3.7	REG075A23A	1
	5.5	REG075A23A	1
	7.5	REG075A23A	1
	11	REG110A23A	1
	15	REG110A23A	1
	18	REG150A23A	1
	22	REG185A23A	1
	30	REG220A23A	1
	37	REG300A23A	1
	45	REG370A23A	1
	55	Please contact the Delta factory	-
	75		
90			

Voltage	10%ED 10s		
	Drive	REG selection	
	kW	Model	Quantity
440V	0.7	REG075A43A	1
	1.5	REG075A43A	1
	2.2	REG075A43A	1
	3.7	REG075A43A	1
	4	REG075A43A	1
	5.5	REG075A43A	1
	7.5	REG075A43A	1
	11	REG075A43A	1
	15	REG110A43A	1
	18	REG150A43A	1
	22	REG185A43A	1
	30	REG220A43A	1
	37	REG300A43A	1
	45	REG370A43A	1
	55	REG450A43A	1
	75	REG550A43A	1
	90	Please contact the Delta factory	-
	110		
	132		
	160		
185			
220			
280			
315			
355			

Model selection method 3 (base on the load characteristics of applications)

Crane/Hoist Application

The equipment weighs 10 tons, drive model: VFD075CH43A, with a 5.5kW motor

From the crane's specification we know

Model No.	V10C4B036I-W18I		Serial No.	
Capacity	10	TON	Duty Cycle	40%ED, ISO M5
Lifting Height	9	m	Hoisting Speed	3.6/0.36 m/min
Trolley Type	W		Traveling Speed	24/2.4 m/min
Main Voltage	380/60	V/Hz	Date	2010/9/15

1. In high-speed operation, the time it takes from top to bottom is $9(\text{m})/3.6(\text{m}/\text{min}) = 2.5(\text{min}) = 150(\text{sec})$
2. Assuming the motor efficiency is 85%, mechanical efficiency is 85%, and the drive and the REG2000's efficiencies are both 95%, the useful power output would be $5.5\text{kW} * 0.85^2 * 0.95^2 = 3.57\text{kW}$
3. When using the REG2000, and mains voltage is 380V, the current would be $3.57\text{kW}/(\sqrt{3} * 380\text{V}) = 5.4 \text{ A}$
4. From the table below, at 40%ED, and a working duration of 150s, the output current must be lower than 90% of the rated current to not cause overloading.
5. From the specification sheet, REG075A43A-21 rated current is 10.5A, $10.5\text{A} * 90\% = 9.45\text{A} > 5.4\text{A}$ therefore, in this case, we can select REG075A43A-21

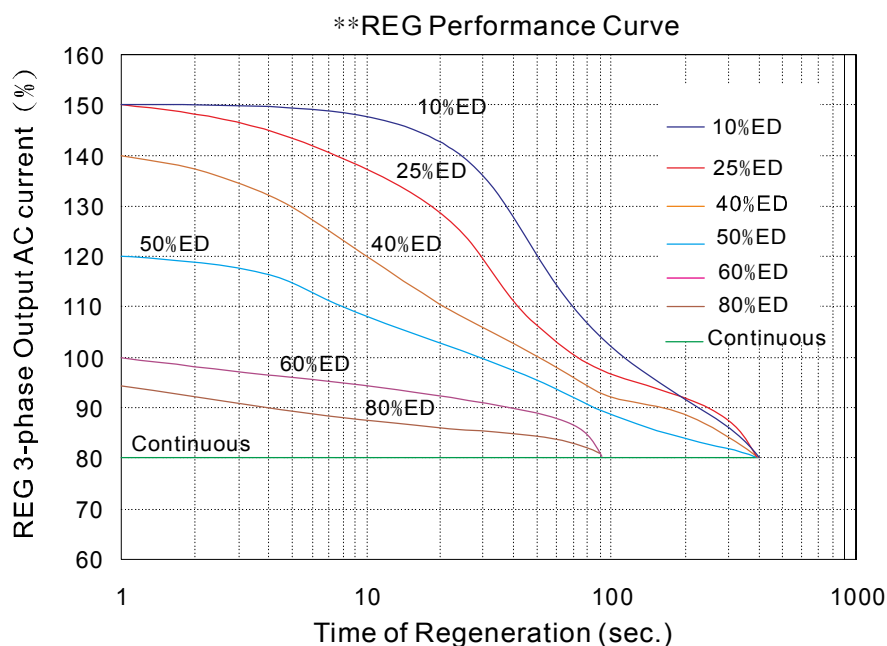

Elevator Application

In an elevator with 2 ton working load, a speed of 60m/min, floors from B1 - 4F, using 22kW motor, and a counterweight of 48%

1. The elevator takes 30s to reach 4F from B1, the whole trip takes 100s, then $ED = 30/100 = 30\%$
2. Assuming the motor efficiency is 85%, mechanical efficiency is 85%, and the drive and the power feedback unit's efficiencies are both 95%, the useful power output would be $22kW * 85% * 85% * 95% * 95% = 14.3kW$
3. When using the REG2000, and mains voltage is 380V, the current would be $14.3kW / (\sqrt{3} * 380V) = 21.8 A$
4. From the table below, at 30%ED, and a working duration of 30s, the output current must be lower than 115% of the rated current to not cause overloading.

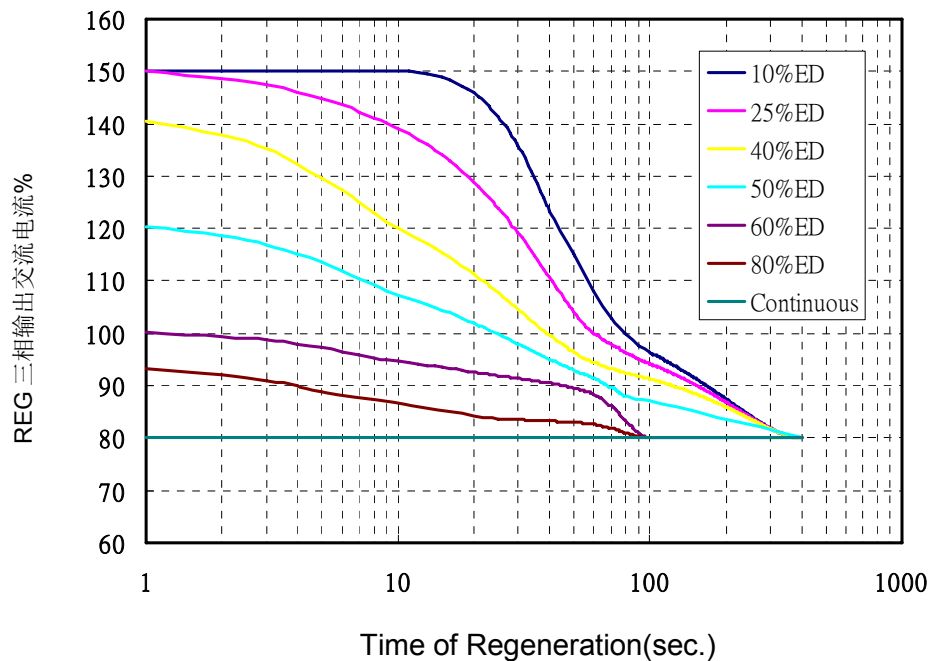

5. From the specification sheet,

REG110A43A-21 if rated current is 17A, $17A * 115% = 19.55A < 21.8A$,

REG150A43A-21 if rated current is 20A, $20A * 115% = 23A > 21.8A$,

Therefore, in this case, we can select REG150A43A-21.