



Delta SCARA DRS40L ASDA-MS Electric Control Instructions

www.deltaww.com

 **DELTA**
Smarter. Greener. Together.

Preface

Thank you for using this product. This manual provides information regarding safe operation of Delta SCARA robot that users must take note in following. Before operating the SCARA robot, to ensure your safety, please be sure to carefully read through this manual. Content of this manual includes:

- Installation and inspection of the robot
- Functions and descriptions for operating the human-machine interface(HMI)
- Checkup and maintenance
- Troubleshooting

Considering operation environment and safety of operating personnel, we offer specialized training for staffs of different types of robot applications. This manual is suitable for reference by the following types of users:

- Designers for integration of system
- Personnel performing installation or wiring
- Personnel performing test run and adjustment on the machine
- Maintenance and inspection personnel
- Personnel operating the equipment

Before using, please read this manual carefully to ensure proper use of the robotic arm. Also, please place the manual at a safe location for reference at any time. Before finishing reading this manual, be sure to follow these guidelines:

- The installation environment must be from water vapor, corrosive, and flammable gas.
- When wiring, do not connect the 3-phase power to the connectors on U, V, W motor. Erroneous connection will damage the servo electrics.
- Grounding must be performed correctly.
- When connecting power, do not disassemble drive, motor, or change wiring.
- Before connecting power to run the robotic arm, make sure the emergency stop device can start at any time.
- When connecting power and running the robotic arm, do not touch heat sink to avoid burn injury.

Should you still have questions on use of the robot, please contact your sales agent or our customer service center.

Safety Precaution

SCARA robot series includes the All-in One ASDA-MS controller which integrates motion controller, robot controller and four servo drives in one single unit with high-speed computing capability. For the safety use, take precaution on safety of the work environment during the operation and ensure safety of operation for the users. Also, the teach pendant and the driver cannot be operated separately.

ASDA-MS series control cabinet can be used on industrial applications and are recommended for installation in a wiring (electric) box specified in the manual (controller, wires, and motors must all be installed in a location that meets the minimum requirement from UL level 1 for the environment of installation). Take the following precautions at any time when receiving, inspecting, installing, wiring, operating, maintaining, and checking the robot.

Meanings represented by symbols for "Danger" , "Warning" , and "Stop" :



- Please follow the methods specified for use with servo drives and servo motors, as doing otherwise might cause fire or failure of equipment.
-



- Means there might be a potential danger that non-compliance might result in medium level hazard, serious damage, or failure of the product.
-



- Means forbidden acts that non-compliance might result in damage or failure of the product beyond use.
-
-

Receiving and inspecting



- Please follow the methods specified for use with the robotic arm, as doing otherwise might cause fire or failure of equipment.
-

Note upon installation



- It is forbidden to expose the product to places with water vapor, corrosive gas, and flammable gas. Otherwise electric shock or fire might result.
-

Note upon wiring



- Please connect ground protection terminals with grounding systems. Improper grounding might result in electric shock or fire.
 - Do not connect three-phase power to U, V, W motor output terminals as personnel injury or fire might result if done otherwise.
 - Tighten fixing screws for the power and motor output terminals, as fire might result if done otherwise.
 - To avoid hazard, refer to selection of wires when performing wiring.
-
-

Note upon operating



- Before starting to run, the robot needs adjustment on settings based on parameters set by users. If not adjusted to the correct matching value, loss of control or failure for the operation of machine might result.
- Before starting to run, make sure the emergency stopping device could be started at any time.



- When robot moves, do not touch any moving part of the robot, as personnel injury might result if done



- After robot connecting, any error in operation will not only cause damages on the robot but also result in bodily harm.
- Strongly recommended: Test to see if the robot would operate normally under no loading and then connect the load to prevent unnecessary hazard.
- Do not touch the controller when running the machine, as doing otherwise might result in burn injury or danger of electric shock because of high temperature.

Maintenance and check



- Do not touch the controller and inside of the robot, as electric shock might result if done otherwise.
- When turning on power, do not disassemble HMI, as electric shock and damage on the HMI might result if done otherwise.
- Do not touch the wiring terminals within 30 minutes after turning off the power as residual voltage may cause electrical shocks.
- Do not change wiring with power on, as electric shock or personnel injury might result if done otherwise.
- Only trained and qualified professional electric personnel are allowed to perform installation, wiring, repairing, and maintaining this robot.

Wiring of circuits



- When wiring, disassemble the terminal base from the servo drive.
- Plug one wire into one plug on the terminal base
- When plugging wires, do not short-circuit the core wire and its nearby wires.
- Before powering on, thoroughly check for proper wiring.



- Do not frequently switch the power on or off. If there is a need to turn the power on and off in succession, keep the frequency below once within one minute.
-

Table of Contents

Preface.....	iii
Safety Precaution.....	iv

1. Product description

1.1 Operating direction.....	1
1.2 Dimensional drawing	2
1.3 Motion range	3
1.4. Robot specification	4
1.5 Specification of ASDA-MS controller	5

2. Wiring sequence

3. Exterior Look of ASDA-MS controller and Descriptions of Connectors

3.1 Exterior look and dimension	8
3.2 Descriptions of external ports on the ASDA-MS controller	9
3.3 Definitions and descriptions for terminals on the ASDA-MS controller	10
3.3.1 Definitions of pins on major loop power terminal:	11
3.3.2 Definitions of pins on control power terminal:	11
3.4 Wiring for ROBOT and controller:	12
3.4.1 Specifications for connectors on the base and controller	12
3.4.2 Definitions for connectors on motor power cable	13
3.4.3 Definitions for connectors for motor brake (BRK.DIO)	14
3.4.4 Definition of Encoder connector	15
3.4.5 STD.DIO connectors	16
DI12 & DI19~DI24.	16
3.4.6 SYS.DIO connectors	17
3.4.7 Specifications of the communication connector	22
3.4.8. I/O Input wiring examples	24
3.4.9 Wiring example of I/O Output	25
3.4.10 SCARA body connector description.....	26

4. Battery replacement

4.1 Notes.....	28
4.2 Battery replacement procedures	29

5. Hardware components

5.1 Connector components	30
5.2 Optional items	32

6. Descriptions for Troubleshooting

6.1 Display of status.....	33
6.1.1 Display of system status.....	33
6.1.2 Display of alert message	34
6.2 Description of P0-01 parameter	34
6.3 Troubleshooting of abnormal alarms	35
6.4 Index of alarm	36
6.4.1 Group type.....	36
6.4.2 Axis type.....	37
6.4.3 Control type.....	38

List of Tables

Table 1-1 Specification of DRS40L series	4
Table 1-2 Specification of ASDA-MS Controller	5
Table 3-1 Manual power pin	10
Table 3-2 Definitions for 4.2 in-flight connectors on motor power cable.....	13
Table 3-4 Definitions of the pins on Encoder connector.....	15
Table 3-5 Definitions of the pins on Delta Encoder	15
Table 3-6 Definitions of pins for user's IO	16
Table 3-7 Definitions of the pins for system IO	16
Table 3-8 Definitions of functions for the system I/O	18
Table 3-9 Definitions of the connectors.....	22
Table 5-1 ASDA-MS Accessories List	30
Table 6-1 System Status Display	33
Table 6-2 Alert Message Display	34
Table 6-3 P0-01 Parameter Description	34
Table 3-3 Definitions of the motor pins	14
Table 3-10 Definitions of RS232/RS485 pins.....	23

List of Figures

Figure 1-1 Directions of SCARA Motions.....	1
Figure 1-2 External Dimension of the SCARA	2
Figure 1-3 SCARA Motion range	3
Figure 2-1 Peripheral Device Wiring Diagram	7
Figure 3-1 Exterior look of ASDA-MS Controller	8
Figure 3-2 Descriptions of external pins on the back of the controller	9
Figure 3-3 Actual main circuit circuit power connector figure.....	11
Figure 3-4 Definition for the motor power terminal.....	11
Figure 3-5 Connector for power on control circuit	11
Figure 3-6 Definition for the control power terminal.....	11
Figure 3-7 Wiring diagram for the SCARA and MS controller	12
Figure 3-8 Motor Power Cable	12
Figure 3-9 Motor Encoder Cable	12
Figure 3-10 Motor connectors	13
Figure 3-11 Connectors on motor power cable.....	13
Figure 3-12 Definitions of Encoder pins	14
Figure 3-13 Brake Release Button Location.....	14
Figure 3-14 Definitions of pins on motor Encoder.....	15
Figure 3-15 Definitions of pins on motor Encoder.....	15
Figure 3-16 External View of the Connectors	16
Figure 3-17 Configuration of Rear Pins	16
Figure 3-18 Definitions of SYS.DIO pins	17
Figure 3-19 E-STOP Wiring Example	18
Figure 3-20 Wiring Example of the Safety Door	18
Figure 3-21 MODE SELECT Wiring Example.....	19
Figure 3-22 RUN/STOP SWITCH Wiring Example	20
Figure 3-23 Reset Wiring Example	20
Figure 3-24 TP connector.....	22
Figure 3-25 Configurations of RS232/RS485 Pins.....	23
Figure 3-26 Ethernet Port.....	23
Figure 3-27 USB B-type port5.	23
Figure 3-28 USB port	23
Figure 3-29 DMCNet port	23
Figure 3-30 Wiring Example of the Button or Inching Switch.....	24
Figure 3-31 Wiring example of proximity switch	24
Figure 3-32 Wiring example of light signal or relay (loading positive).....	25
Figure 3-33 Wiring example of light signal or relay (loading negative))	25
Figure 3-34 SCARA Body Connector Configuration	26
Figure 3-35 SCARA I/O Connector Description	26

Figure 3-36 SCARA Air Tube Configuration.....	27
Figure 5-1 Delta DC24V Power Supply	32
Figure 6-1 7-segment Display	33
Figure 6-2 Display of MS board.....	34
Figure 6-3 Seven-segment display of MS error code.....	35

1. Product description

1.1 Operating direction

DSR40L series is a robot consisted of four axes, which are first arm (J1), second arm (J2), axis Z (J3), and axis R (J4). Directions of their motions are shown in Figure 1-1 Directions of SCARA Motions, with (+) and (-) on the graph representing directions of each axis defined by user in the editor program.

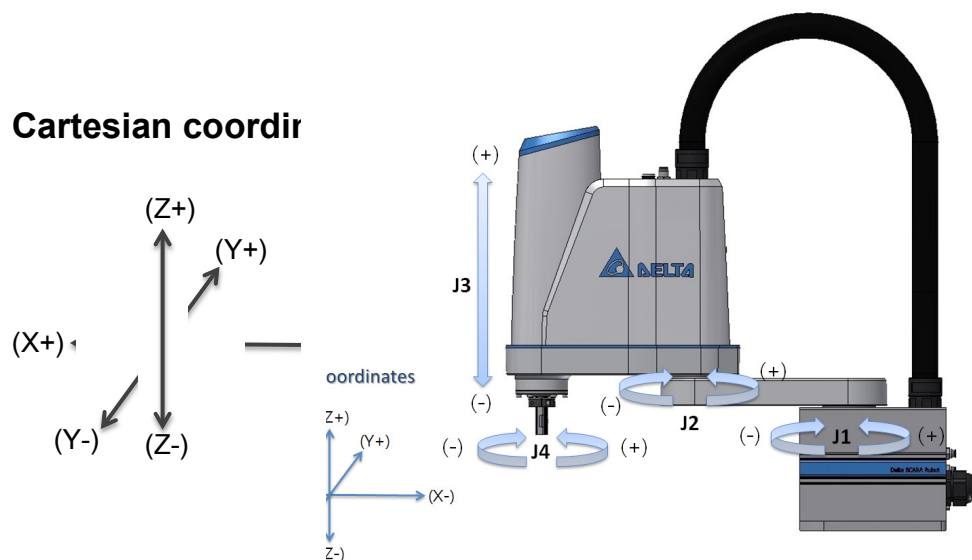
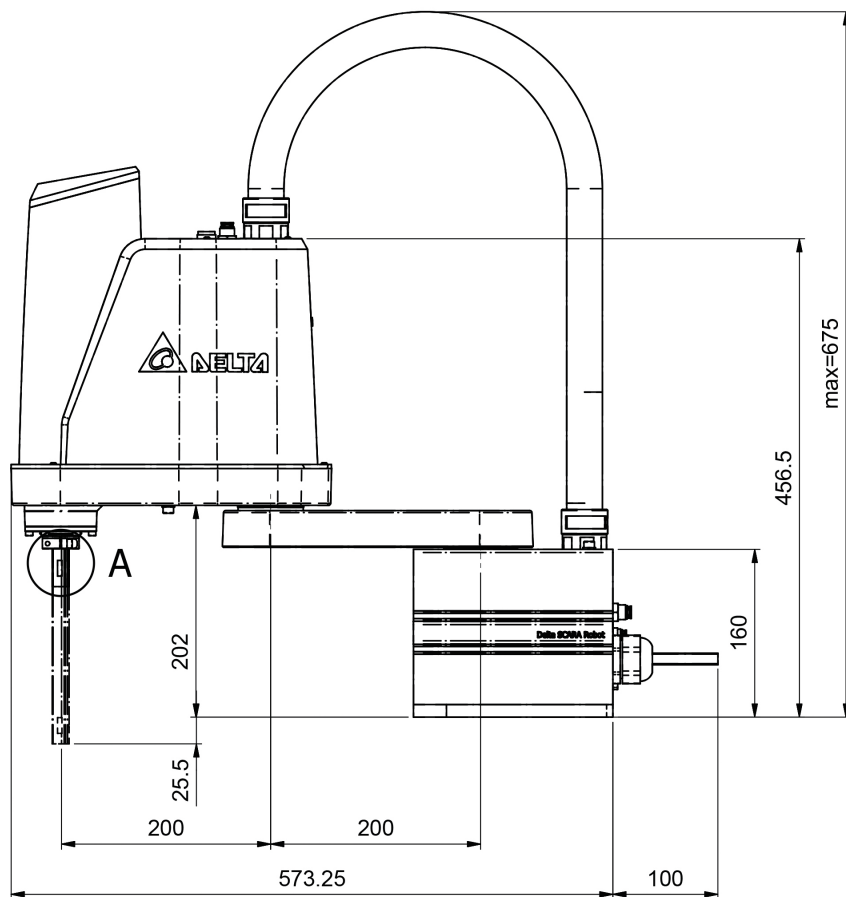
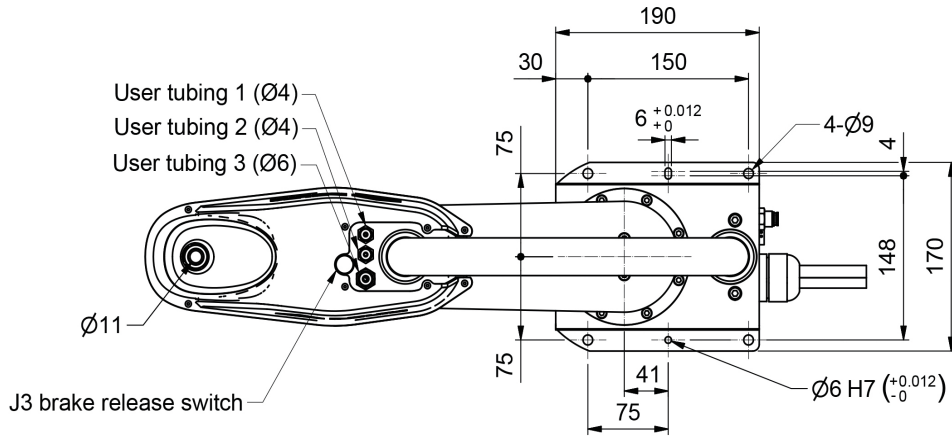

Figure 1-1 Directions of SCARA Motions

1.2 Dimensional drawing

External dimensions of the mechanism are shown in Figure 1-2. Please use 4-M8 locking screws to secure the mechanism on a platform



Unit: mm

Figure 1-2 External Dimension of the SCARA

1.3 Motion range

When SCARA robots line up, the maximum turning radius for first arm is 400 mm and the range of rotation movement is $\pm 130^\circ$; when first arm reaches its limit, second arm can move for other 100° to reach its limit. The maximum turning radius for second arm is 200 mm and the range of rotation movement is $\pm 146.6^\circ$. The detailed motion range of SCARA is as shown in Figure 1-3.

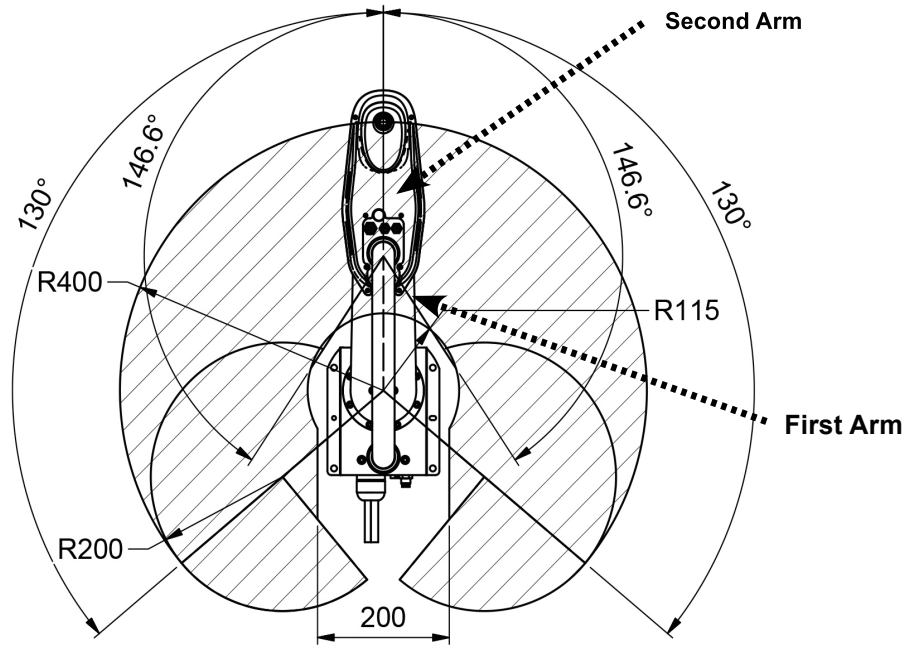

X-axis mechanical stopper position : 133°
 Y-axis mechanical stopper position : 148.3°

Figure 1-3 SCARA Motion range

1.4. Robot specification

The specification of DRS40L series is shown in Table 1-1.

Table 1-1 Specification of DRS40L series

Model		DRS40L
Axis count		4
Arm length(Arm 1+Arm 2)		400 mm
Rated/Maximum payload		1 Kg / 3 Kg
Maximum speed	X-Y	4710 mm / sec
	Z	1250 mm / sec
	R	1875° / sec
Range of motion	J1	±130°
	J2	±146.6°
	Z	150 mm
	RZ	±360°
Standard time for a cycle *		0.42 sec
Accuracy of repetition	X/Y	±0.01 mm
	Z	±0.01 mm
	R	±0.01°
Motor power	J1	200 W
	J2	200 W
	Z	100 W
	RZ	100 W
Rated/max. pressing strength (Z)		100 / 250N
Max. allowable load inertia (R)		0.0091 / 0.075 Kg-m ²
Cable connector for customer installation		15Pin D-Sub
Air pipe for customer installation		ø4 mmx2, ø6 mmx1
Body weight		16 Kg

*25mm-300mm-25mm & Payload: 1Kg, test environment temperature 25oC, environmental relative humidity 45% ~ 65% RH

*Delta reserves the right to change specifications without further notice.

1.5 Specification of ASDA-MS controller

The detailed specification shown as below:

Table 1-2 Specification of ASDA-MS Controller

Model ASDA-MS series		
Power Supply	Phase Number / Voltage	Single phase: 200~230V _{AC} , -15%~10%, 23.8A (for DRS40L: 5A)
	Control Power Supply	24V _{DC} , -10%~10%, 5A (for DRS40L: 3A)
Size (W) X (H) X (D) mm / Weight		175 mm x 300 mm x 159 mm / 5.6 kg
Cooling Method		Fan cooling
External Optical Scale or Encoder		A, B, and Z format
Robot Control	Programming Language	Delta robot language
	Motion Model	Point-to-point motion, linear interpolation, and circular interpolation
	Memory Capacity	20MB: for programming editor and data users 1K location point is available for global variables (which can be shared among different programs). 30K location point is available for all programming editors.
Input / Output	Standard I/O	User I/O: 24 sets of input and 12 sets of output System I/O: 8 sets of output and 8 sets of input
	Communication Interface	Ethernet One channel
Communication Interface	RS-232 / RS-485	One connecting port (one connecting port allows switching between two communication functions)
	DMCNET	One channel
	USB Host	Two connecting port
	Environmental Specification	Installation Site Indoor (avoid direct sunlight) and no corrosive vapor (avoid oily fume, inflammable gas, and dust)
Environmental Specification	Elevation	Less than 1000M above sea level
	Atmosphere Pressure	86 kPa ~ 106 kPa
	Ambient Temperature	0°C ~ 55°C (Please force surrounding air circulation when ambient temperature is above 45°C)
	Storage Temperature	-20°C ~ 65°C
	Humidity	0 ~ 90% RH (no fog)
	Vibration	9.80665 m/s ² (1G) below 20 Hz, 20 ~ 50 Hz 5.88 m/s ² (0.6G)
	IP Grade	IP20
	Electrical System	TN system*
Safety Certification		IEC/EN 61800-5-1, UL 508C, C-tick
		

Note: TN system refers to that the neutral point of the electrical system is directly connected to the ground and the exposed metal components are connected to the ground via protective grounding conductor.

2. Wiring sequence

1. Please lock SCARA and the ASDA-MS drive controller in place properly.

2. Connect SCARA and the ASDA -MS drive controller:

(1) Encoder Cable: Connect the encoder connector of the encoder cable to the motor encoder feedback connector on ASDA-MS.

(2) Motor Power Cable:

A. Connect the power connector of the power cable to the servo motor output (U, V, W) on the ASDA-MS; please note the connector label when connecting and do not connect the wrong cable.

B. Connect the brake connector of the power cable to the BRK.DIO connector on the ASDA-MS and connect the brake input power. Please refer to 3.4.3 break connector (BRK.DIO) definitions for the BRK.DIO pins.

3. E-STOP signal: Please connect the E-STOP cable properly and please refer to the E-STOP wiring example as illustrated in 3.4.6 SYS.DIO connector.

4. Connecting the power:

(1) Main circuit power input: Connect the single-phase AC 200V to 230V single-phase 50/60 Hz to the main circuit power input terminal of the drive controller and properly ground it.

(2) Control circuit power input: Connect 24V (3A) DC power (please use Class 2) to supply control power for the ASDA-MS drive controller.

5. Teach pendant can be purchased optionally.

(1) Please insert or remove the teach pendant when it is unpowered.

(2) If the teach pendant is not connected, please connect the teach pendant short-circuit connector.

Please refer to the specification manual for details on the specifications of the teach pendant

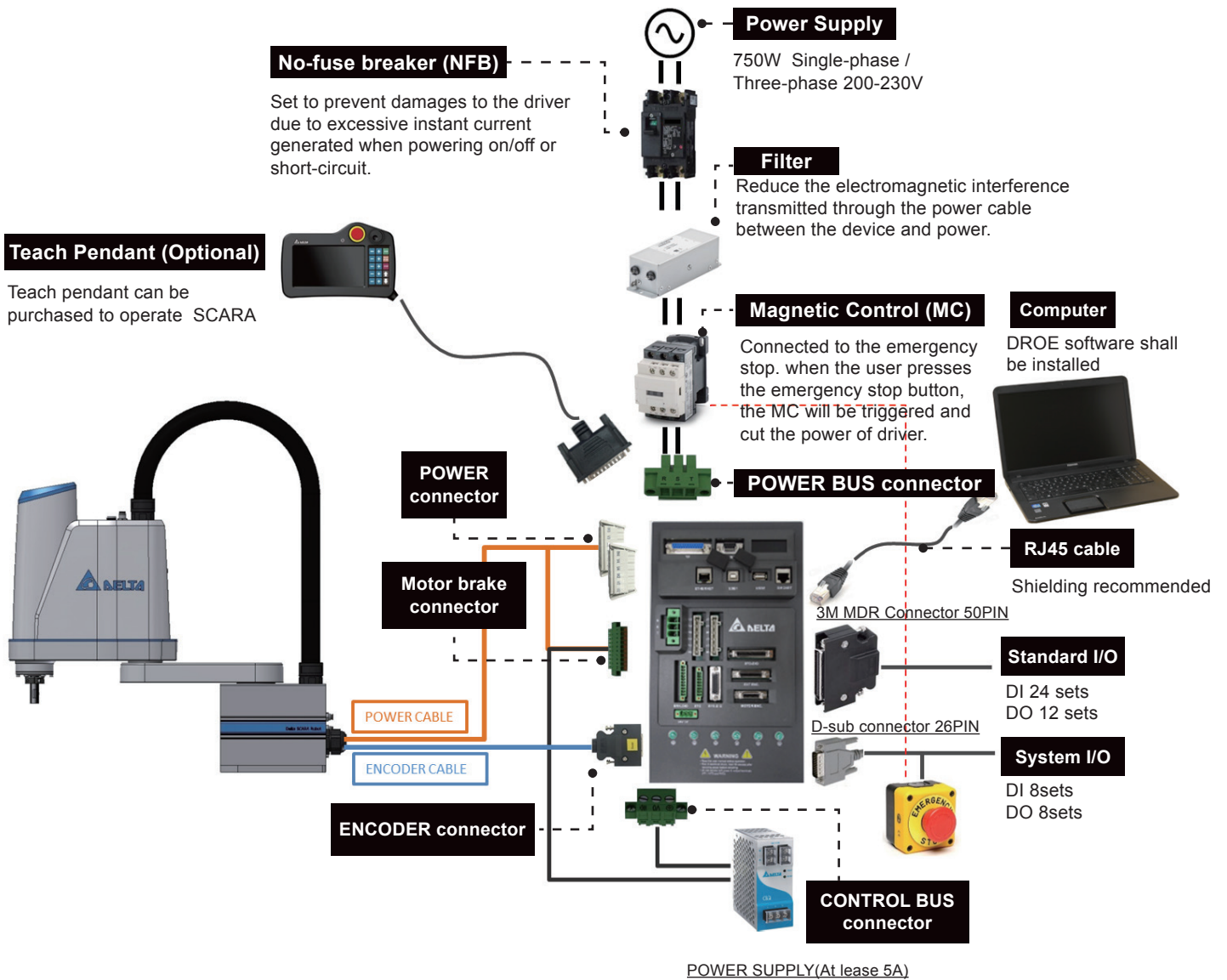

Figure 2-1 Peripheral Device Wiring Diagram

3. Exterior Look of ASDA-MS controller and Descriptions of Connectors

3.1 Exterior look and dimension

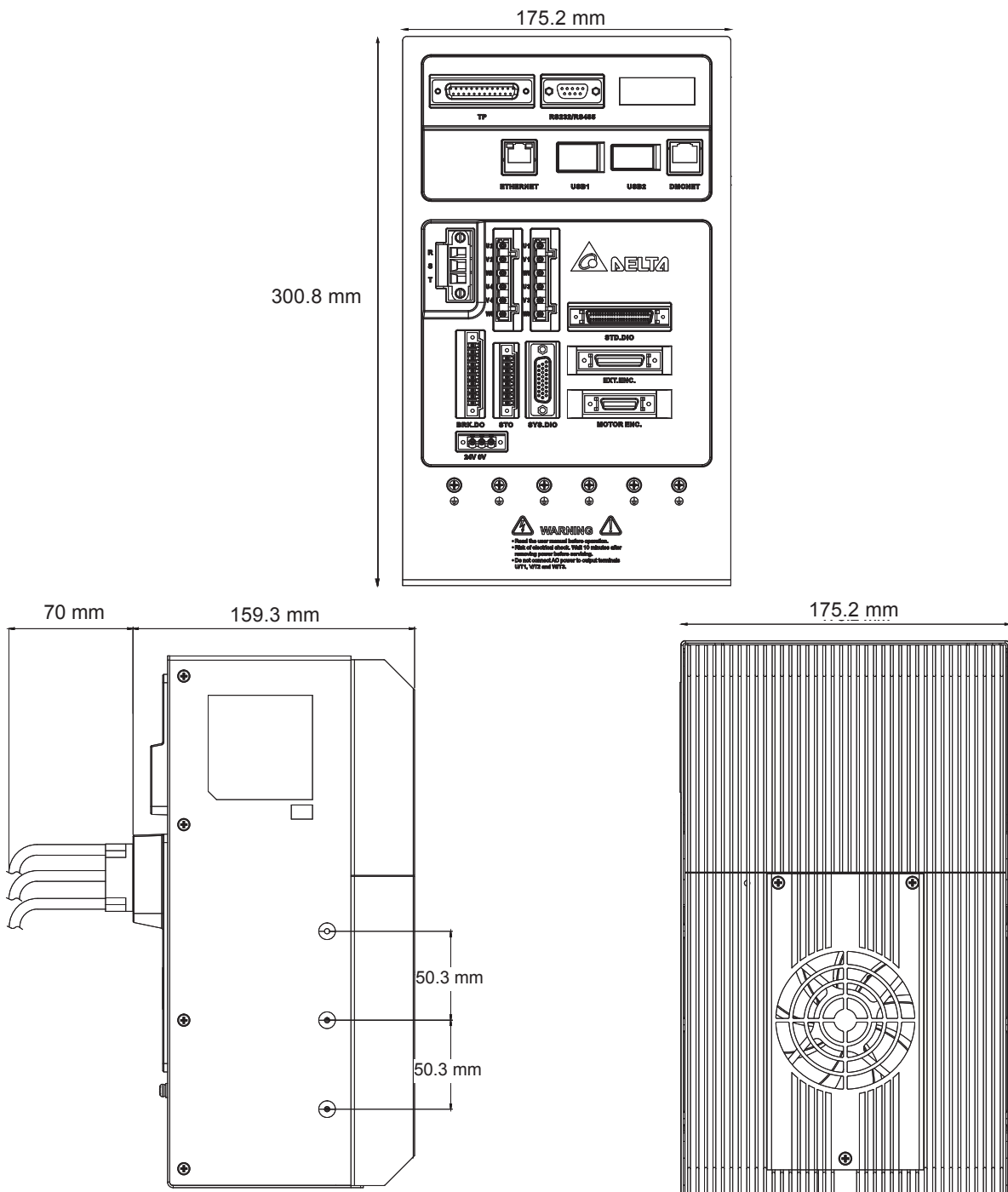

Figure 3-1 Exterior look of ASDA-MS Controller

3.2 Descriptions of external ports on the ASDA-MS controller

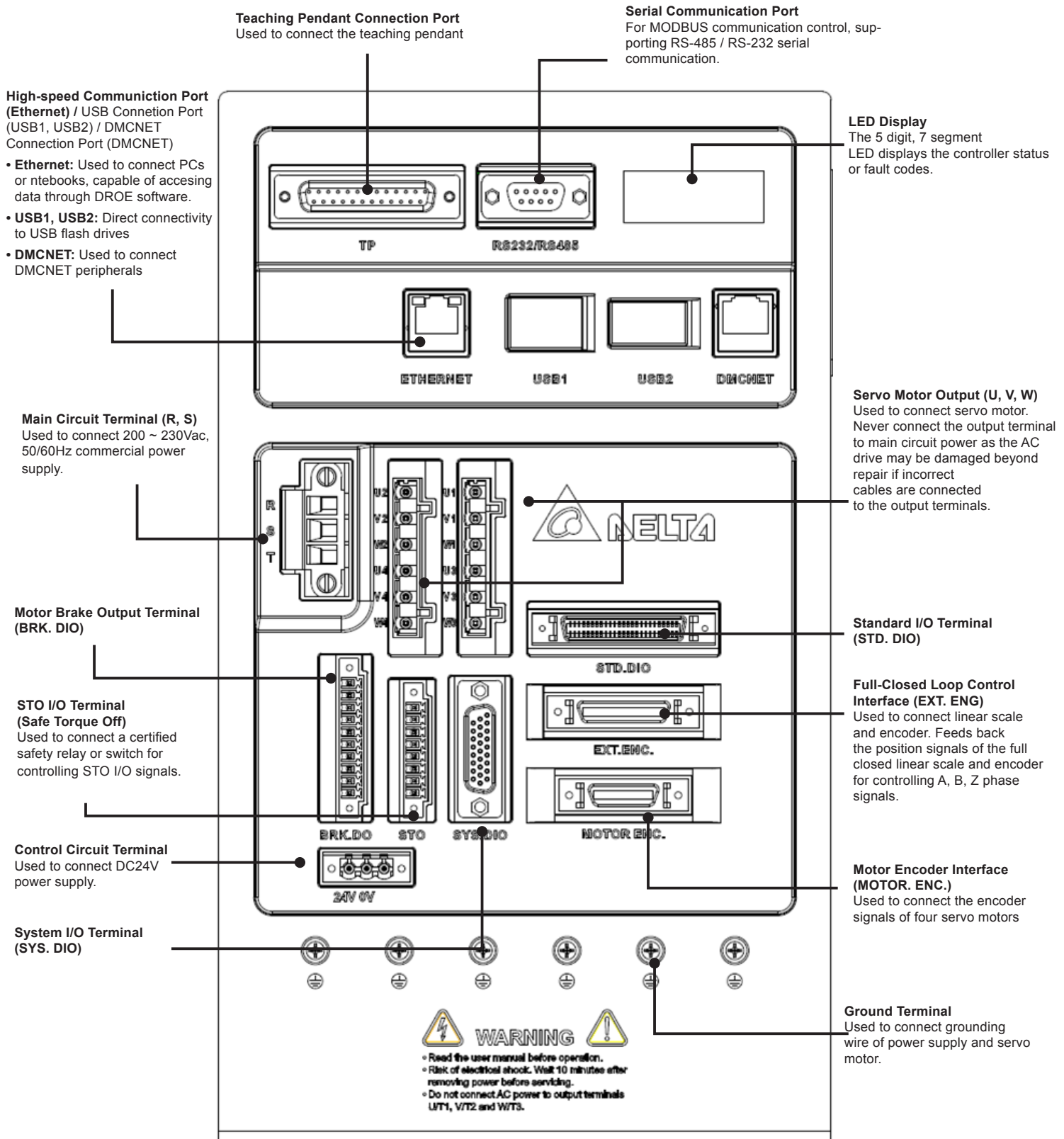



Figure 3-2 Descriptions of external pins on the back of the controller

3.3 Definitions and descriptions for terminals on the ASDA-MS controller

Table 3-1 Manual power pin

Terminal marking	Name	Description	
24V, 0V	24V power input end	Connect 24V DC power supply	
R, S,	Power input end for major loop	Connect single-phase AC power supply (220V AC)	
U1, V1, W1 U2, V2, W2 U3, V3, W3 U4, V4, W4 FG	Motor connecting wire	Connect to the motor power cable	
		Terminal marking	Description
		U	Main power cable for the motor
		V	
W			
FG		Connect to grounding terminal of the drive 	
	Grounding terminal	Connect with ground wires for the power supply and motor	
STD.DIO	I/O connector	Connect USER I/O	
SYS.DIO	I/O connector	Connect SYSTEM I/O	
BRK.DIO	DO connector	Release electromagnetic brake on the motor	
EXT.ENC.	Encoder connector	Connect external Encode	
Motor ENC.	Encoder connector	Connect the motor Encode	
TP	Teach Pendant connector	Connect HMI interface	
RS232	Communication port connector	Connect RS-232 (supports Modbus ASCII Server)	
RS485	Communication port connector	Connect RS-485	
ETHERNET	Communication port connector	Connect the internet (supports Modbus TCP/IP Server)	
USB1	Communication port connector	Connect PC	
USB2	Communication port connector	Connect USB drive	
DMCNET	Communication port connector	Connect related Delta products	

3.3.1 Definitions of pins on major loop power terminal:

The circuit input terminal of the main circuit; connect AC 200V to 230V single-phase 50/60 Hz input power.



Figure 3-3 Actual main circuit circuit power connector figure

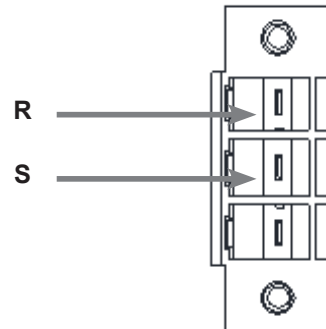

Figure 3-4 Definition for the motor power terminal

3.3.2 Definitions of pins on control power terminal:

Connect +24VDC (3A) input power to the control circuit input terminal.



Figure 3-5 Connector for power on control circuit

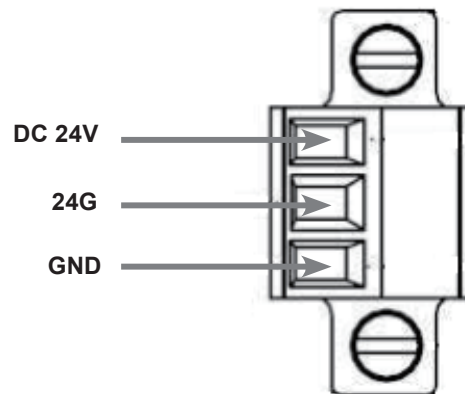

Figure 3-6 Definition for the control power terminal

3.4 Wiring for ROBOT and controller:

Two cables must be connected between the controller and SCARA body:

- 1. Motor Power Cable:** The outlet connectors from the base of SCARA are two sets of 6P male connectors which are connected to the female ports for **MOTOR POWER** on the controller; and J3 brake is connected to Pin 5 and Pin 6 on the **BRK.DIO** port, the cable of button for unlocking J3 brake connect to Pin 1 on the **BRK.DIO** port.
- 2. Encoder Cable:** The connector from the base of SCARA is MDR 26PIN connectors and connects to MOTOR ENC on the controller.

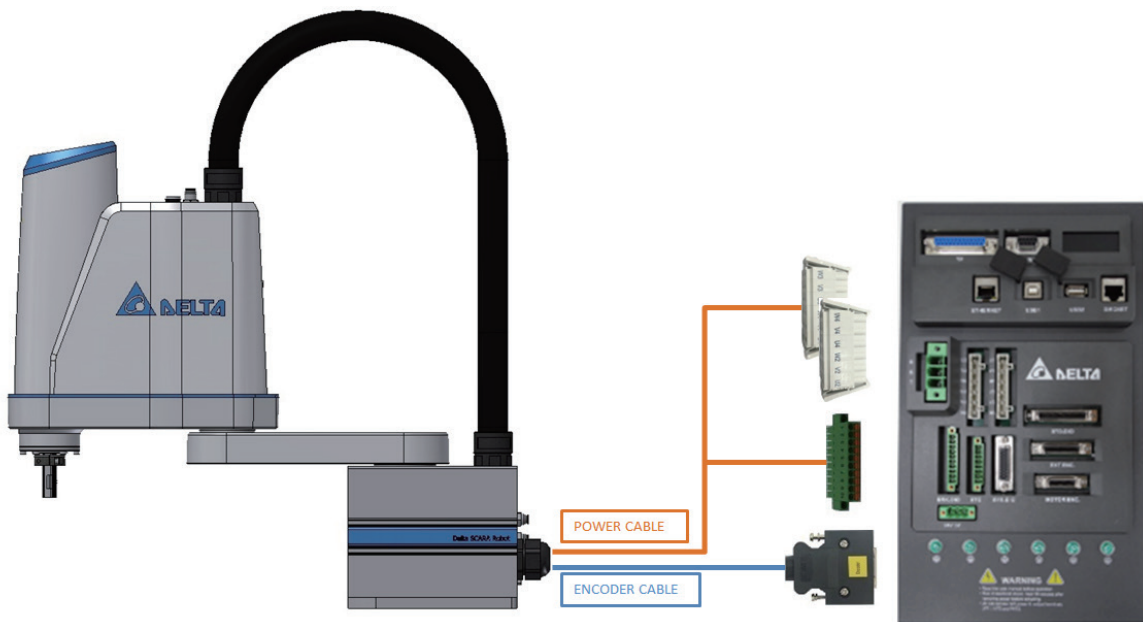

Figure 3-7 Wiring diagram for the SCARA and MS controller

3.4.1 Specifications for connectors on the base and controller

- 1. Motor power cable:** 0.75mm² *20C (Shield) + [DINKLE] 0134-34-06P*2
- 2. Encoder cable:** 24AWG * 8 P + [3M] MDR 26PIN



Figure 3-8 Motor Power Cable



Figure 3-9 Motor Encoder Cable

3.4.2 Definitions for connectors on motor power cable

The connectors are connected to the motor power cable and shall be connected according to U, V and W specifications. Part of the power cable use the same connectors J1+J3 and J2+J4 shared by both axis, so the marking shall be made when inserting the connectors.

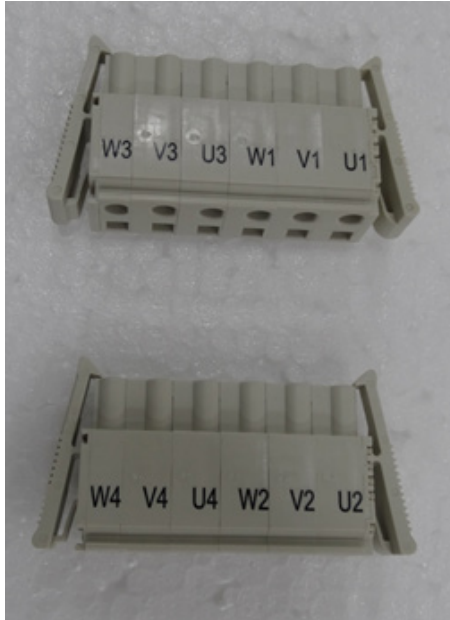

Figure 3-10 Motor connectors

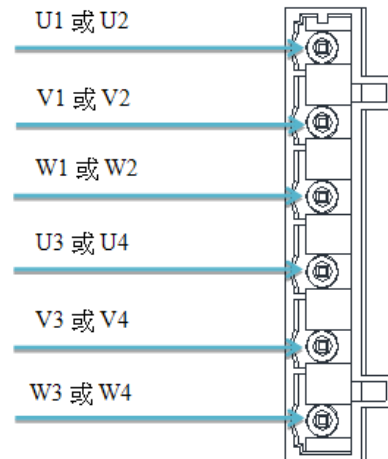

Figure 3-11 Connectors on motor power cable

Table 3-2 Definitions for 4.2 in-flight connectors on motor power cable

Motor POWER connectors					
Pin	Definition	Description	Pin	Definition	Description
1	U1	J1 motor power supply	1	U2	J2 motor power supply
2	V1	J1 motor power supply	2	V2	J2 motor power supply
3	W1	J1 motor power supply	3	W2	J2 motor power supply
4	U3	J3 motor power supply	4	U4	J4 motor power supply
5	V3	J3 motor power supply	5	V4	J4 motor power supply
6	W3	J3 motor power supply	6	W4	J4 motor power supply

3.4.3 Definitions for connectors for motor brake (BRK.DIO)

This function mainly provides DC24V to release the motor from its brake status. Through communication function, it utilizes DO function to give orders to output the signal for unlocking the brake. This connector provides four sets of signals to unlock motor brake. Out of the four groups, one is for use by SCARA J3 vertical axis and the other is for use by the button to release motor brake on J3 axis. Figure 3-12 Definitions of pins for motor brake

Pin definition:

1. J3 axis motor brake signal: ZBK and 24G are connected to Pin5 and Pin6.
2. Signal for release of button on J3 axis motor brake: 24V is connected to Pin1

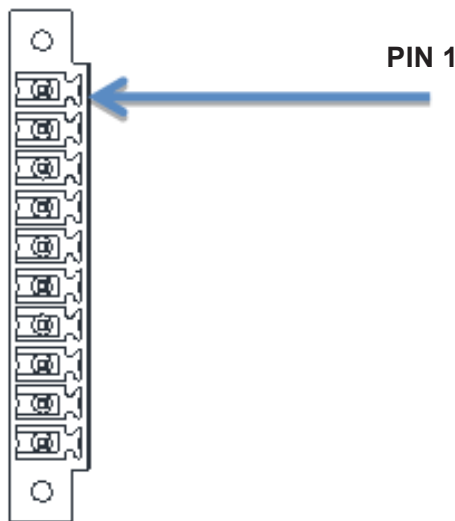

Table 3-3 Definitions of the motor pins

PIN	NAME
1	24V Always on
2	0V
3	MOTOR BRAKE 24VDC
4	0V
5	MOTOR J3 BRAKE 24VDC
6	0V
7	MOTOR BRAKE 24VDC
8	0V
9	INPUT 24V DC
10	INPUT 0V

Figure 3-12 Definitions of Encoder pins



Brake release button function description:

This button is located on the head of SCARA, as shown in the figure to the left; if the system servo went off and caused the J3 axle brake to lock down, pressing this button will release the J3 brake, allowing users to manually move the J3 axle and perform operations more conveniently.

Note: If load is added to the head, users must beware that when this button is pressed, the unlocked J3 axle break will slide downwards.

Note: if loads are added on the top, watch out for fall down of J3 axis unlocking brake with this button pressed.

Figure 3-13 Brake Release Button Location

3.4.4 Definition of Encoder connector

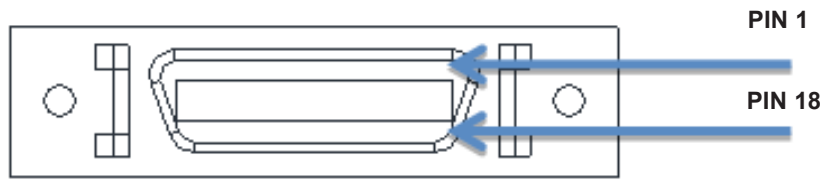

Figure 3-14 Definitions of pins on motor Encoder

1. The connector accepts input via motor pulse.

Table 3-4 Definitions of the pins on Encoder connector

PIN	NAME	PIN	NAME	PIN	NAME	PIN	NAME
1		2		14		15	
3		4	5V	16	5V	17	T+_3
5	T+_1	6	GND	18	GND	19	T-_3
7	T-_1	8		20		21	
9		10	5V	22	5V	23	T+_4
11	T+_2	12	GND	24	GND	25	T-_4
13	T-_2			26			

2. Motor Encode connector

This connector is connected to the motor Encode cable.

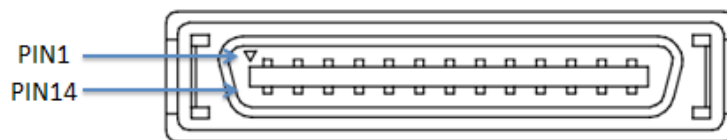

Figure 3-15 Definitions of pins on motor Encoder

Table 3-5 Definitions of the pins on Delta Encoder

PIN	NAME	PIN	NAME	PIN	NAME	PIN	NAME
1	Z+_1	2	Z-_1	19	Z+_3	20	Z-_3
3	B+_1	4	B-_1	21	B+_3	22	B-_3
5	A+_1	6	A-_1	23	A+_3	24	A-_3
7	5V	8	GND	25	5V	26	GND
9	X	10	X	27	X	28	X
11	GND	12	5V	29	GND	30	5V
13	Z+_2	14	Z-_2	31	Z+_4	32	Z-_4
15	B+_2	16	B-_2	33	B+_4	34	B-_4
17	A+_2	18	A-_2	35	A+_4	36	A-_4

3.4.5 STD.DIO connectors

The connector is defined based on pins used for input and output by the user's IO. Currently, the internally planned I/O is described as follows and the other parts are available to users.

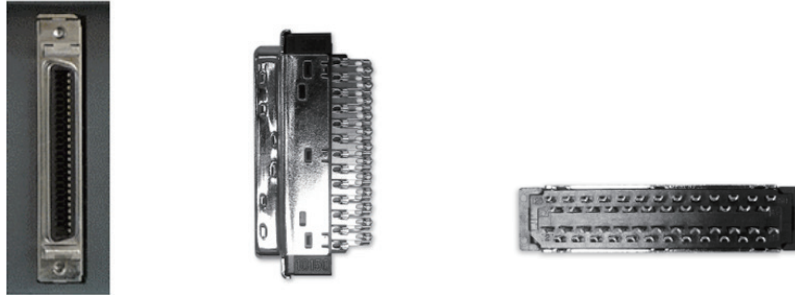

Figure 3-16 External View of the Connectors

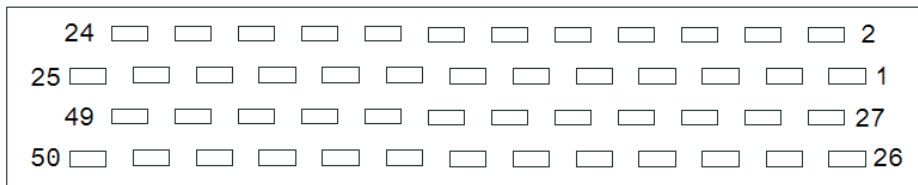

Figure 3-17 Configuration of Rear Pins

Table 3-6 Definitions of pins for user's IO

PIN	NAME	PIN	NAME	PIN	NAME	PIN	NAME
1	DI1	2	DI2	26	DI7	27	DI8
3	DI3	4	DI4	28	DI9	29	DI10
5	DI5	6	DI6	30	DI11	31	DI12
7	DI13	8	DI14	32	DI19	33	DI20
9	DI15	10	DI16	34	DI21	35	DI22
11	DI17	12	DI18	36	DI23	37	DI24
13	DI_COM1	14	DO01+	38	DI_COM2	39	DO01-
15	DO02+	16	DO03+	40	DO02-	41	DO03-
17	DO04+	18	DO05+	42	DO04-	43	DO05-
19	DO06+	20	DO07+	44	DO06-	45	DO07
21	DO08+	22	DO09+	46	DO08-	47	DO09-
23	DO10+	24	DO11+	48	DO10-	49	DO11-
25	DO12+			50	DO12-		

Note. DI_COM1 is the ground of DI1~DI6 & DI13~DI18, DI_COM2 is the ground of DI7~DI12 & DI19~DI24.

3.4.6 SYS.DIO connectors

The connectors are defined based on pins used for output and input by the system IO.

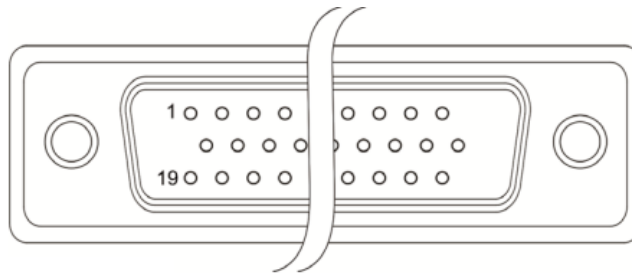

Figure 3-18 Definitions of SYS.DIO pins

PIN	NAME	PIN	NAME	PIN	NAME
1	DO3-	10	DO2-	19	DO5+
2	DO3+	11	DO2+	20	DO5-
3	DO4-	12	DO7-	21	DO6-
4	DO4+	13	DO7+	22	DO6+
5	DI_COM3	14	DO1+	23	DO8-
6	DI_COM3	15	DO1-	24	DO8+
7	DI5	16	DI1	25	DI2
8	DI3	17	DI6	26	DI7
9	DI8	18	DI4		

PLC INPUT	FUNTION
DI1	E-STOP
DI2	SAFETY DOOR
DI3	SAFETY DOOR
DI4	MODE SELECT
DI5	MODE SELECT
DI6	RUN/STOP SWITCH2
DI7	RUN/STOP SWITCH2
DI8	RESET
DO1	Group Alarm status
DO2	Group Servo status
DO3	Group positioning status
DO4	Grating trigger status
DO5	RL running status (same as how the IO controls the RL running status)
DO6	RL running status (same as how the IO controls the RL running status)
DO7	Controller ready status
DO8	Reserved

Table 3-7 Definitions of the pins for system IO

Table 3-8 Definitions of functions for the system I/O

● **E-STOP signal:**

E-STOP Input is the DI1 (Pin16) connected to SYS.DIO, therefore users must connect DI1 of this connector to the external emergency stop button switch to use. E-STOP wiring example is as shown in the figure.

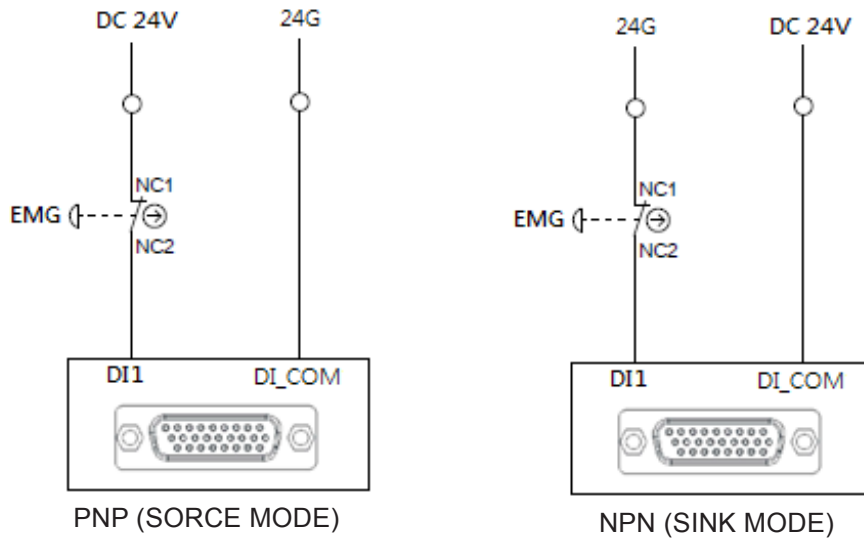

Figure 3-19 E-STOP Wiring Example

● **SAFETY DOOR Signal**

There are two input points planned on the safety door; DI2 is the door opening detection sensor input and DI3 is the door reversion ready button. As shown in the figure.

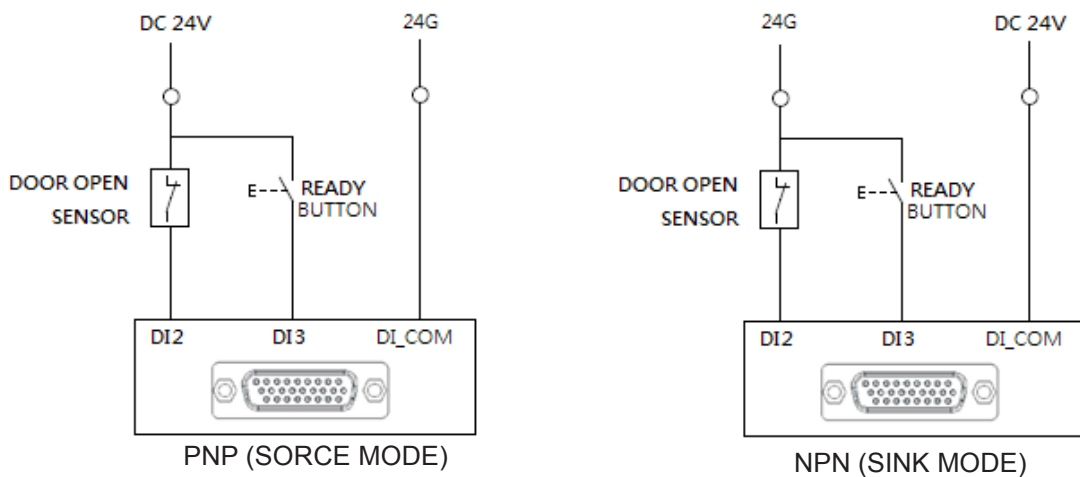

Figure 3-20 Wiring Example of the Safety Door

3. EXTERIOR LOOK OF ASDA-MS CONTROLLER AND DESCRIPTIONS OF CONNECTORS

● MODE SELECT Signal

The mode selection is planned via 2 input points, as shown in the figure below.

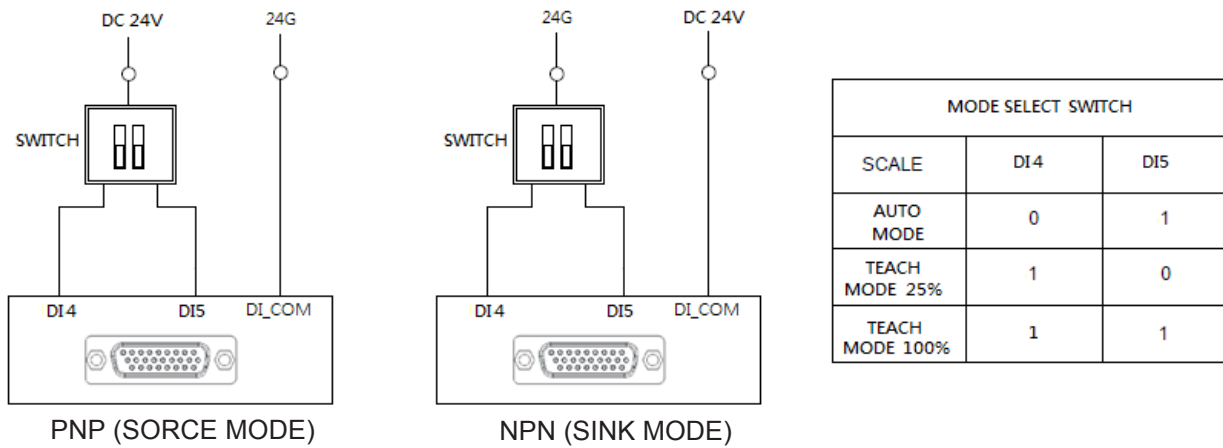

Figure 3-21 MODE SELECT Wiring Example

Item Mode	DI		Description	Note
	DI4	DI5		
Disconnected	0	0	<ul style="list-style-type: none"> The controller LED displays E1.998 	This mode will be deactivated after the wire is connected correctly.
Auto Mode	0	1	<ul style="list-style-type: none"> The user must not use the teach pendant to control the robot. The user may use the PC to control the robot. The user may use the systematic digital input to control the operation 	The JOG synthetic speed shall not exceed 250 mm/s (latch JOG and shaft JOG)
T1 Mode	1	1	<ul style="list-style-type: none"> The maximum running speed is less than 250 mm/s. The user may use the teach pendant to control the robot. The user may use the PC to control the robot. The user may not use the systematic digital input to control the operation. 	The JOG synthetic speed shall not exceed 250 mm/s (latch JOG and shaft JOG)
T2 Mode	1	1	<ul style="list-style-type: none"> The maximum running speed is 2000 mm/s. The user may use the teach pendant to control the robot. The user may use the PC to control the robot. The user may not use the systematic digital input to control the operation. 	The maximum running speed is less than 250 mm/s.

● **RUN/STOP SWITCH signal**

The operating mode selection is planned via 2 input points under the AUTO MODE, as shown in the figure.

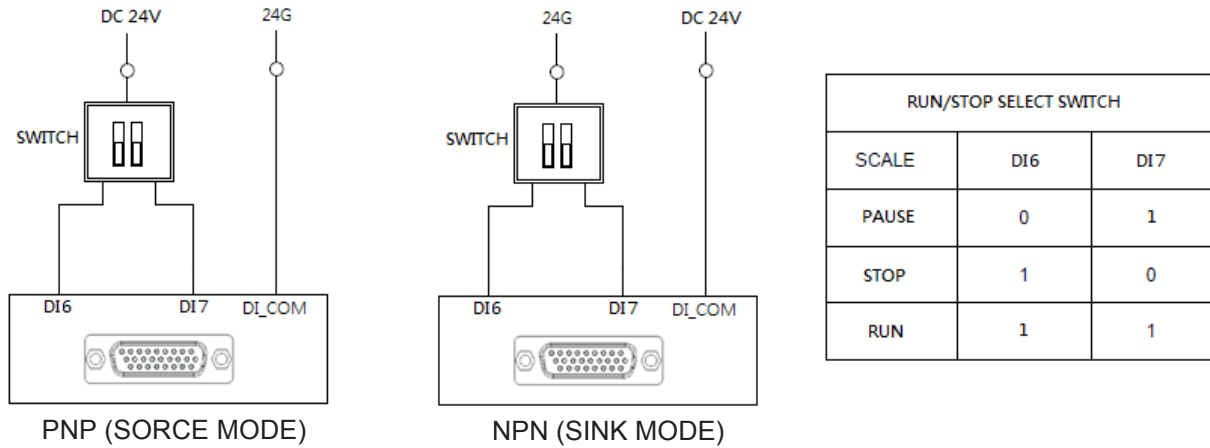

Figure 3-22 RUN/STOP SWITCH Wiring Example

● **Reset signal**

It is an input of Reset signal, which can reset alarm and abnormal states by means of external button, as shown in the figure.

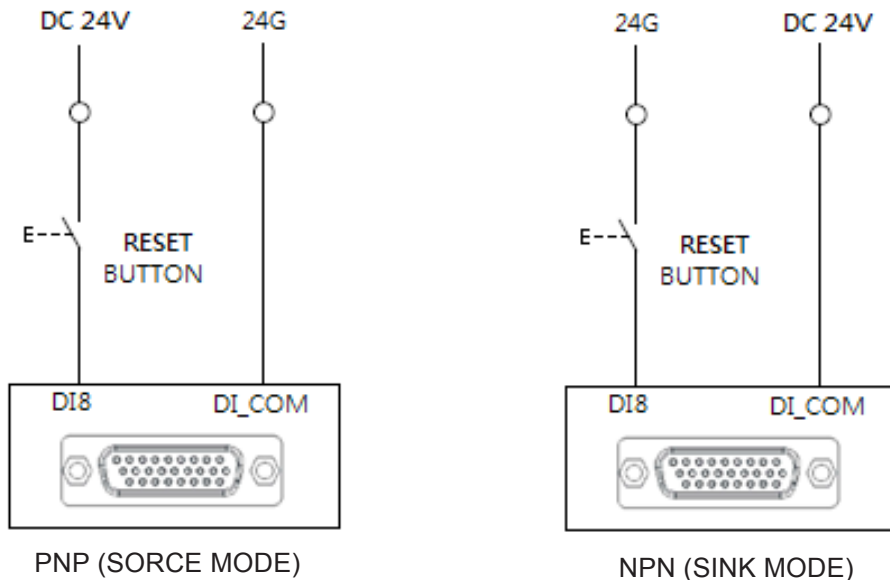

Figure 3-23 Reset Wiring Example

2. DO Instruction

- Display for the alarm description of the robot
This is the description for the status of the systematic digital output SysDO1

SysDOStatus		ON		OFF	
		ON		OFF	
Item					
SysDO1		The abnormal alarm status shows.		There is no abnormal alarm status.	

- Display of the servo status regarding the robot
This is the description for the status of the systematic digital output SysDO2.

SysDOStatus		ON		OFF	
		ON		OFF	
Item					
SysDO2		The servo motor is on.		The servo motor is off.	

- Display of the positioning status regarding the robot
This is the description for the status of the systematic digital output SysDO3.

SysDOStatus		ON		OFF	
		ON		OFF	
Item					
SysDO3		The robot is moving.		The robot reaches a position and stops.	

- Display of the status regarding the functional temporary suspension
This is the description for the status of the systematic digital output SysDO4

SysDOStatus		ON		OFF	
		ON		OFF	
Item					
SysDO4		This function is not triggered.		This function is triggered.	

- Display of the program operating status
This is the description for the status of the systematic digital outputs SysDO4 and SysDO5.

SysDO5 Status		ON		OFF	
		ON		OFF	
SysDO4 Status					
ON		The program is operating.		The program operation stops.	
OFF		The program operation pauses.		None	

- The display of the ready status regarding the controller.
This is the description for the status of the systematic digital output SysDO7.

SysDOStatus		ON		OFF	
		ON		OFF	
Item					
SysDO7		The controller function is ready.		The controller function is not ready.	

3.4.7 Specifications of the communication connector

1. TP connector

The connector is connected to HMI.

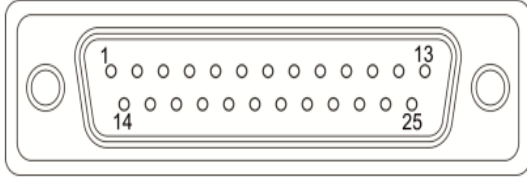

Figure 3-24 TP connector

Table 3-9 Definitions of the connectors

D-SUB 25PIN		
Pin No	FUNCTION	TWISTED
1	ETH_TX+	TWISTED PAIR
2	ETH_TX-	
3	DGND	
7	E-STOP_NO+(NO)	TWISTED PAIR
8	E-STOP_NO-(NO)	
9	E-STOP_NO+(NC)	TWISTED PAIR
10	E-STOP_NO-(NC)	
13	24V	
14	ETH_RX+	TWISTED PAIR
15	ETH_RX-	
18	PW	
20	ENC_EXA	TWISTED PAIR
21	ENC_EXB	
22	ENSW_NC+	TWISTED PAIR
23	ENSW_NC-	
25	PW	
17	-	Reserved
18	PW	24V
19	GND	0V
20	ENC_EXA	Enter TP hand wheel (A)
21	ENC_EXB	Enter TP hand wheel (B)
22	ENSW_NC+	Inching(NC)
23	ENSW_NC-	Inching(NC)
24	PW	24V
25	PW	24V

2. RS232RS485 connector

The connector is used for communication bus (serial communication).

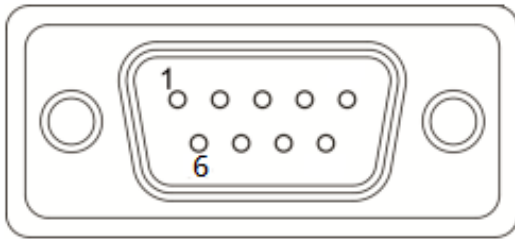

Figure 3-25 Configurations of RS232/RS485 Pins

Table 3-10 Definitions of RS232/RS485 pins

PIN	NAME	PIN	NAME
1	RS485+	6	RS485-
2	RS232_RX	7	X
3	RS232_TX	8	X
4	X	9	X
5	GND		

3. ETHERNET connector

The connector is used for network communication.

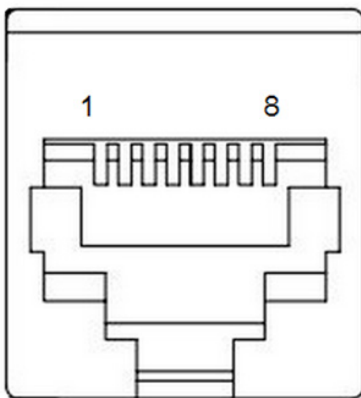

- 1. TXP : EtherNet TX+
- 2. TXN : EtherNet TX-
- 3. RXP : EtherNet RX+
- 4. - : Reserved
- 5. - : Reserved
- 6. RXN : EtherNet RX-
- 7. - : Reserved

Figure 3-26 Ethernet Port

4. USB B-type connectors

The connectors are used for communication cables (USB 2.0 communication).

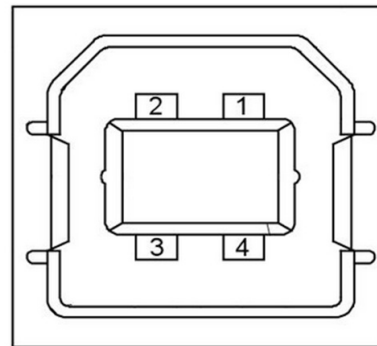

- 1. V bus : DC+5V
- 2. D- : Data-
- 3. D+ : Data+
- 4. GND

Figure 3-27 USB B-type port5.

5. USB A-type connectors

The connectors are used for communication cables (USB 1.1 communication).

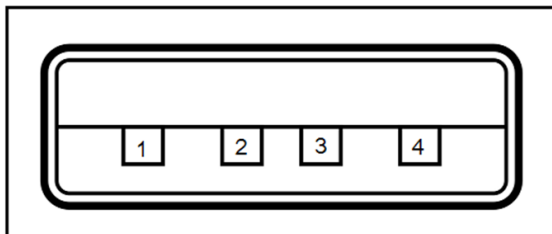

- 1. V bus : DC+5V
- 2. D- : Data-
- 3. D+ : Data+
- 4. GND

Figure 3-28 USB port

6. DMCNET connectors

The connectors are used for the communication bus (serial communication).

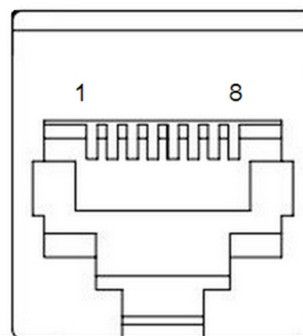

- 1. DMC_A1 : DMCNET1+
- 2. DMC_B1 : DMCNET1-
- 3. DMC_A2 : DMCNET2+
- 4. - : Reserved
- 5. - : Reserved
- 6. DMC_B2 : DMCNET2-
- 7. - : Reserved
- 8. - : Reserved

Figure 3-29 DMCNet port

3.4.8. I/O Input wiring examples

- **Button or inching switch**

I/O connector (MDR 50pin Female)

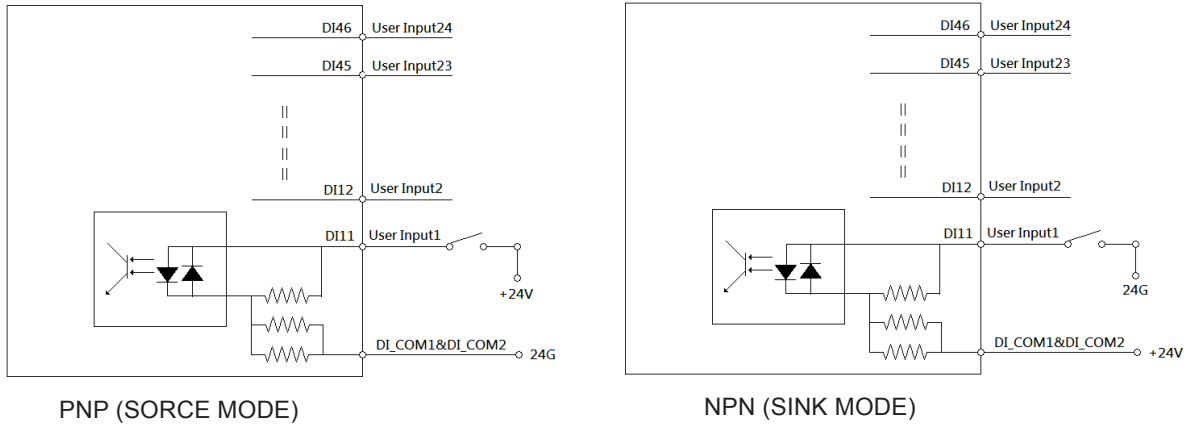

Figure 3-30 Wiring Example of the Button or Inching Switch

- **Proximity Switch**

I/O connector (MDR 50pin Female)

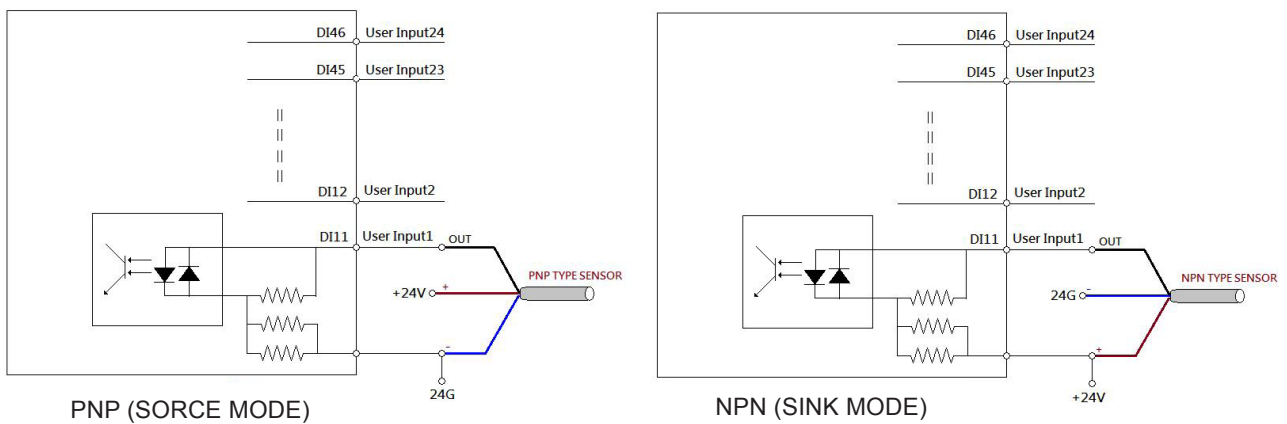

Figure 3-31 Wiring example of proximity switch

3.4.9 Wiring example of I/O Output

- Light signal or relay (loading negative)

I/O connector (MDR 50pin Female)

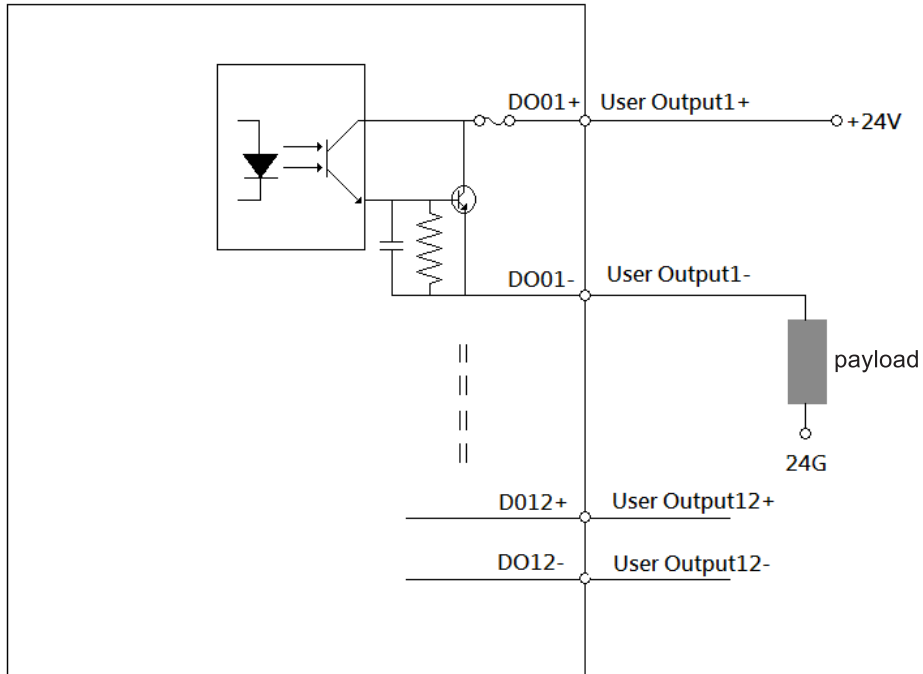

Figure 3-32 Wiring example of light signal or relay (loading positive)

- Light signal or relay (loading positive)

I/O connector (MDR 50pin Female)

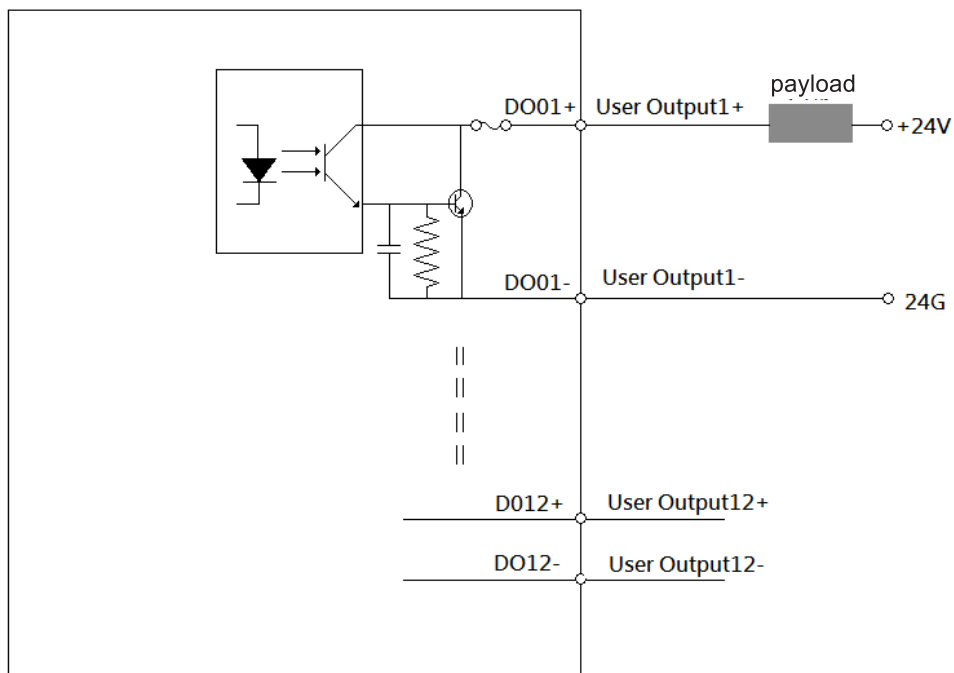

Figure 3-33 Wiring example of light signal or relay (loading negative)

3.4.10 SCARA body connector description

For user friendliness, one group of signal connectors and three groups of air tubes are provided on the SCARA robot for use by customers:

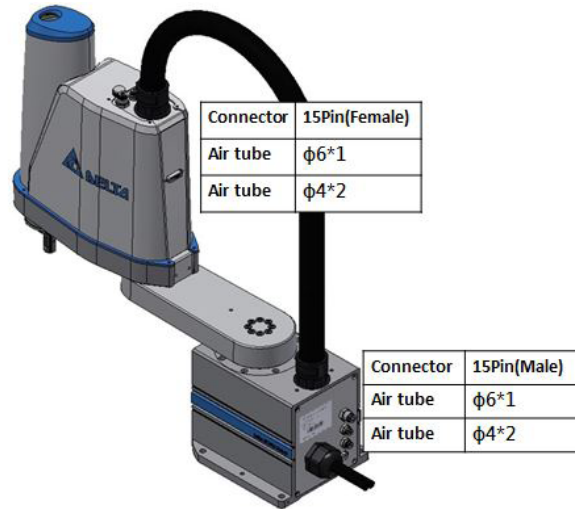

Figure 3-34 SCARA Body Connector Configuration

1. Signal connector description

D-Sub15 pin is adopted for the connector. The head part is female connector, and the base part is male connector. Please use them according to the signal connectors for the accessory package, with pin locations shown as follows:

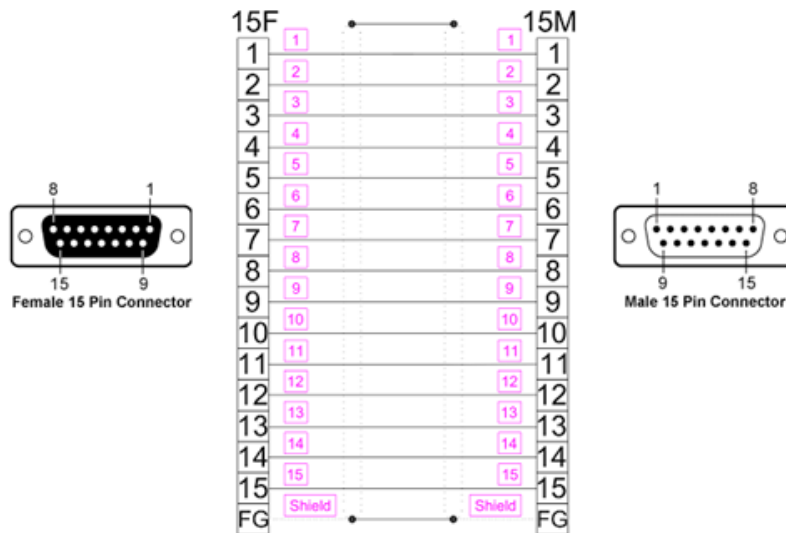

Figure 3-35 SCARA I/O Connector Description

2. Air tube description

Sequence for configuring SCARA body air tube containing 1 * ϕ 6, 2* ϕ 4 is as follows:

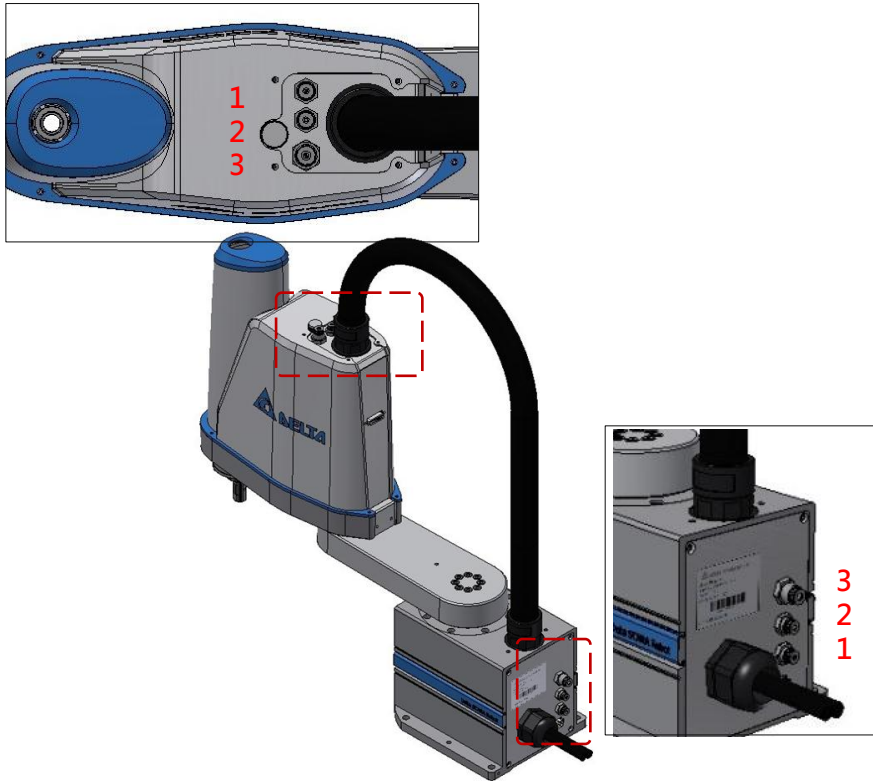

Figure 3-36 SCARA Air Tube Configuration

4. Battery replacement

4.1 Notes

1. Display of Alarm AL061 on the drive suggests overly low voltage that the battery shall be replaced.
2. When the value displayed by Parameter P0-02 is 31, namely the voltage is less than 3.1, the battery must be replaced immediately to prevent loss of data.
3. The battery voltage less than 2.7V will cause loss of data on absolute position, please exchange batteries in 3 days.
4. Replacement of the battery is recommended when the drive is powered on, so as to avoid loss of data on absolute position.
5. Please install new batteries within 5 minutes after removing the old ones, so as to avoid loss of data on absolute position.
6. Please proceed with the home return again when the data on the absolute position is lost.

4.2 Battery replacement procedures

1. Remove the front plate on the SCARA body, behind which is where the batteries are placed.



Figure 4-1 Battery placement location

(Do not remove the metal seats for securing the batteries!
The following flow chart only serves for illustration.)

2. First pull out the connector for the battery to be replaced.



Figure 4-2 Battery Replacement Step 1

3. Remove the old battery from the battery holder.



Figure 4-3 Battery Replacement Step 2

4. Install a new battery into the battery holder. Insert the connector and then pull out the connector for another battery.



Figure 4-4 Battery Replacement Step 3

5. Remove another old battery from the battery holder.



Figure 4-5 Battery Replacement Step 4

6. The following battery replacement steps are the same. Install the rest of new batteries into the holders and insert the connectors to complete the replacement.



Figure 4-6 Battery Replacement Step 5

5. Hardware components

5.1 Connector components

Table 5-1 ASDA-MS Accessories List

ITEM	Picture	NAME	NOTES	Q'TY
1		MOTOR POWER Connector J1&J3	3050248246	1
2		MOTOR POWER Connector J2&J4	3050248646	
3		MAIN POWER INPUT Connector	3051611346	1
4		DC 24V INPUT Connector	3051627346	1
5		Motor brake release Connector	3051618746	1

ITEM	Picture	NAME	NOTES	Q'TY
6		Base CN1 Connector	3074051921	1
7		Base CN1 Connector Cover	3050284421	1
8		Head CN2 Connector	3074051821	1
9		Head CN2 Connector Cover	3050284121	1
10		Controller STD I/O Connector	307740100L	1
11		Controller STD I/O Connector Cover	305059000L	1
12		Controller SYS I/O connector	307280183C	1
13		Controller SYS I/O Connector Cover	305005303C	1
14		Short-circuit connector of Teach Pendant for the controller box	3050594900	1

5.2 Optional items

1. DC24V Power Supply

Recommended Model name:

150W: PMC-24V150W1AA

200W: PMC-24V200W1AA



Figure 5-1 Delta DC24V Power Supply

Note: Select Delta Power Supply – Output DC24V series as needed.

Please refer to the Delta <http://www.deltapsu.com/products/din-rail-power-supply?serie=cliq>

2. Filter :

Recommended Model name :

EMF023A21A

<http://www.delta-americas.com/Products/CategoryListT1.aspx?CID=0406&PID=ALL&hl=en-US>

6. Descriptions for Troubleshooting

6.1 Display of status

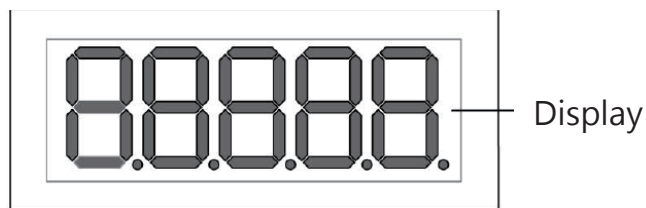







Figure 6-1 7-segment Display

6.1.1 Display of system status

Table 6-1 System Status Display

Display symbol	Description
	Status of powering on or restarting
	Power on completed
	Displayed during firmware update
	Displayed when burning
	Burning completed

6.1.2 Display of alert message

Table 6-2 Alert Message Display

Display symbol	Description
 <p>(Error d : axis13 Error code : 013)</p>	<p>The first code: fixed display of “E”</p> <p>The second code: Type</p> <ol style="list-style-type: none"> 1. Controller: “C” 2. Group: number 1 (use decimal points to represent the group) 3. Axis: use binary-coded decimal system to represent the axis, such as 1~6, 13~16, 17, 18 (1~6, D~G, H, I). 4. User: “U” <p>The last three digits: for the meaning of the Error Code, please refer to P0-01 Parameter Description or Chapter 6.3 for Troubleshooting</p>

6.2 Description of P0-01 parameter

When 0 is written in P0-01 to clear the error code, the panel display will restore the following status.



Figure 6-2 Display of MS board

If there is Error not cleared during the reading, the numerical value being not 0 and of 32 bits shall be sent back. The first 16 bits represent the Index and the last 16 bits represent Error code, as shown in the table below.

Table 6-3 P0-01 Parameter Description

Index(16-bits)				Error code (16-bits)
U	Z	Y	X	Error Code (WORD)
NO		Reserved (0x0)	Type	

Symbol	Description
U, Z	NO: represents the number for Group or Axis and the size is 4-bits
Y	System reserved, size 4-bits
X	Type, size 4-bits (1) 0x0: Controller (2) 0x1: Group (3) 0x2: Axis (4) 0x3: User (5) 0x4~0xF: system reserved
Error Code	Refer to Chapter6.3 Troubleshooting for Abnormal Alarms

6.3 Troubleshooting of abnormal alarms

There are 4 major categories of abnormal alarms, namely the control type, customized type, group type, and axis type, the meanings of which are described as follows:

- Control type: alarms sent out by the controller.
- Customized type: alarms customized by the users through the PLC program written.
- Group type: alarms sent out by a group which is combined randomly from an axis group.
- Axis type: alarms sent out by individual axis.





The 7-segment display shows the abnormal alarm code in the following way.



Figure 6-3 Seven-segment display of MS error code

1. Fixed display for abnormal alarm E

2.

Control type (Controller):	C This type of abnormal alarm is currently reserved.
Customized type (User):	U
Group type (Group):	1-2 * “?” is used to represent numbers in the List of Abnormal Alarms.
Axial type (Axis):	1-6 axis: number 1-6. 7-12 axis: reserved. 13-18 axis: English letter D-I * “?” is used to represent numbers and English letters in the List of Abnormal Alarms.
For example:	
 Abnormal alarm code E1.803 is the alarm of Group 1 in the group type.	
 Abnormal alarm code E1803 is the alarm of Axis 1 in the axial type.	
 Abnormal alarm code ED803 is the alarm of Axis 13 in the axial type.	
 Abnormal alarm code EI803 is the alarm of Axis 18 in the axial type.	

3. Codes for Abnormal Alarms

6.4 Index of alarm

6.4.1 Group type

Abnormal Alarm Display	Abnormal Alarm Name	Abnormal Alarm Type		Servo Status	
		ALM	WARN	ON	OFF
E?801	Axis did not return to the origin	○			○
E?803	Incompatible motion command	○			○
E?80A	Motion command is not ready	○			○
E?80B	Unknown motion command	○			○
E?80C	Error of the motion command in buffer region	○			○
E?813	Axis error during interpretation of commands	○			○
E?814	Axis error during implementation of the motion commands	○			○
E?815	Mono-axis exceeds the software limit	○			○
E?821	Arm gesture is inconsistent	○			○
E?822	Target position for P2P motion command is out of Robot's operating range	○			○
E?823	Target position of command for continuous path is out of Robot's operating range	○			○
E?824	Spatial movement exceeds the operating range of Robot	○			○
E?825	P2P movement path exceeds the operating range of Robot	○			○
E?827	Group does not exist	○			○
E?829	Error in switching the coordinates	○			○
E?82A	Error in switching user coordinates	○			○
E?82B	Error in switching tool coordinates	○			○
E?832	Loss of internal communication packet	○			○
E?833	Error in check code for internal communication	○			○
E?841	The arc command is out of boundary	○			○
E?842	The arc cannot be formed	○			○
E?843	Arc mode error	○			○
E?851	Time out error in transmission of vision parameters followed by conveyor belt	○			○
E?852	The following speed for conveyor belt exceeds limits	○			○
E?853	Overtime error in transmission of vision parameters followed by conveyor belt	○			○
E?861	The jogging speed of the TP hand wheel is too fast.	○			○
E?862	The TP hand wheel is jogging.	○			○

Note :

If there's other alarm code appearing, please contact the technique team or agent directly for further support.
 "?" represents the number of "1. ~ 2." in the alarm of group type.

6.4.2 Axis type

Abnormal Alarm Display	Abnormal Alarm Name	Abnormal Alarm Type		Servo State	
		ALM	WARN	ON	OFF
E?001	Overcurrent	○			○
E?002	Overvoltage	○			○
E?003	Low voltage		○		○
E?004	Motor matching error	○			○
E?005	Retrogradation error	○			○
E?006	Overload	○			○
E?007	Over speed	○			○
E?009	Error in position control is too large	○			○
E?011	Encoder abnormal	○			○
E?012	Calibration abnormal	○			○
E?013	Emergency stop		○		○
E?014	Reverse limit abnormal		○		○
E?015	Direct limit abnormal		○	○	
E?016	IGBT overheated	○			○
E?017	Memory abnormal	○			○
E?018	Detector output abnormal	○			○
E?019	Serial communication abnormal between controller and drive	○			○
E?020	Overtime in sSerial communication between controller and drive		○	○	
E?022	Power abnormal on the main loop		○		○
E?023	Advanced overload warning		○	○	
E?024	Error in Initial magnetic field for the internal encoder	○			○
E?025	Internal error on the encoder	○			○
E?026	Error in reliability of internal data for the encoder	○			○
E?027	Error in internal reset for the encoder	○			○
E?028	High voltage on the encoder or internal error on the encoder	○			○
E?029	Gray code error	○			○
E?030	Motor collision error	○			○
E?031	Detection on disconnection of the motor power cable	○			○
E?034	Error in internal communication for the encoder	○			○
E?035	Encoder temperature exceeded protection limit.	○			○
E?044	Warning on usage of the drive functions		○		
E?060	Loss of absolute position		○		○
E?061	Low voltage error on the encoder		○	○	

Abnormal Alarm Display	Abnormal Alarm Name	Abnormal Alarm Type		Servo State	
		ALM	WARN	ON	OFF
E?062	Absolute position laps overflow		○	○	
E?067	Encoder temperature alarm		○	○	
E?069	Motor type error	○			○
E?06A	Loss of absolute position				
E?070	Incomplete encoder processing		○		○
E?099	EEPROM needs updating	○			○
E?111	DMCNET packet receiver overflows	○			○
E?185	DMCNET Bus hardware abnormal	○			○
E?201	Initial error of DMCNET data	○			○
E?235	Position command overflows	○			○
E?245	Positioning overtime	○			○
E?283	Drive direct limit		○	○	
E?285	Drive reverse limit		○	○	
E?289	Position counter overflows	○			○
E?301	DMCNET synchronizing signal failed	○			○
E?302	DMCNET synchronizing signal is too fast	○			○
E?303	DMCNET synchronizing signal overtime	○			○
E?304	DMCNET IP command invalid	○			○
E?500	STO function is activated	○			○
E?501	STO_A lost	○			○
E?502	STO_B lost	○			○
E?503	STO_error	○			○
E?555	Drive failure	○			○

Note:
 "?"represents the number of "1~6"and alphabet"D ~ I" in the alarm of axis type

6.4.3 Control type

Abnormal Alarm Display	Abnormal Alarm Name	Abnormal Alarm Type		Servo State	
		ALM	WARN	ON	OFF
EC001	PLC timeout	○			○
EC002	PLC Image load failed	○			○
EC003	PLC Exception	○			○
EC004	Motion module failed	○			○
EC005	Controller failed	○			○
EC006	Continuous 30 second write in alarm	○			○
EC007	DMCNET device setting mismatch	○			○
EC008	Mechanism parameter file load failed	○			○
EC009	Robot Type inconsistent	○			○
E1998	Operation mode not started	○			○

● Group type:

E?801 Axis did not return to the origin	
Cause	Axis did not return to the origin
Check and Correction	If the axis fails to return to the origin before the coordinates moved, please return the axis to the origin.
Solution	Reset alarm

E?803 Incompatible motion command	
Cause	The motion command does not support over-lapping mode
Check and Correction	Whether commands such as mono-axial P2P (MovJ), multi-axial P2P (MovP, MovPR, MArchP) and spatial commands (MovL, MovLR, MArc, MCircle, MArchL) are blended at the same time since these three types of motion commands cannot overlap. Please use other motion commands to replace or avoid command overlapping.
Solution	Reset alarm

E?80A Motion command is not ready	
Cause	The motion command is not ready and cannot be interpreted.
Check and Correction	Return to the dealer or original manufacturer for repairing.
Solution	Reset alarm

E?80B Unknown motion command	
Cause	The motion command cannot be identified.
Check and Correction	Return it to the dealer or original manufacturer for repairing.
Solution	Reset alarm

E?80C Error of the motion command in buffer region	
Cause	Error in Interpretation of the motion command for cache region.
Check and Correction	Return it to the dealer or original manufacturer for repairing.
Solution	Reset alarm

E?813 Axis error during interpretation of commands	
Cause	Axis error during interpretation of commands.
Check and Correction	Please use the original software (DROE) to check whether any abnormality of axis is found and eliminate any abnormality in accordance with the troubleshooting of alarms.
Solution	Reset alarm

E?814 Axis error during implementation of motion commands	
Cause	Axis error during implementation of the motion commands.
Check and Correction	Please use the original software (DROE) to check whether any abnormality of axis is found and eliminate any abnormality in accordance with the troubleshooting of alarms.
Solution	Reset alarm

E?815 Mono-axis exceeds the software limit	
Cause	Target position of the mono-axis exceeds the software limit.
Check and Correction	Whether target position of the command for each axis is within configured limits of software. If not, please move the arm (manual or Jog) back into the limits of software.
Solution	Reset alarm

E?821 Arm gesture is inconsistent	
Cause	Current arm gesture is inconsistent with gesture at target position.
Check and Correction	<ol style="list-style-type: none"> 1. Continuous path command (MovL, MArc, MCircle, MArchL) does not support movements under hand changes. Check whether the gesture at current position is consistent with that at the target position. If not, please change the gesture at target position or use another motion command. 2. Please check whether this motion path can be ignored. If not, then determine the arm gesture with the controller.
Solution	Reset alarm

E?822 Target position for P2P motion command is out of Robot's operating range	
Cause	The target position for issued mono-axial P2P (MovJ), multi-axial P2P (MovP, MovPR, MArchP) is out of the operating range.
Check and Correction	Whether the target position of the motion command for each axis is within the software limits configured by the drive.
Solution	Reset alarm

E?823 Target position of command for continuous path is out of Robot's operating range	
Cause	The target position of spatial command issued (MovL, MovLR, MArc, MCircle, MArchL) is out of the operating range.
Check and Correction	Whether the target position of the motion command for each axis is within the software limits configured by the drive.
Solution	Reset alarm

E?824 Spatial movement exceeds the operating range of Robot	
Cause	Spatial command movement exceeds the operating range of Robot.
Check and Correction	Whether the target position of the motion command for each axis is within the configured limits of software.
Solution	Reset alarm

E?825 P2P movement path exceeds the operating range of Robot	
Cause	Error of computation for forward kinematics. Path of movements for mono-axial/multi-axial P2P commands exceeds the operating range.
Check and Correction	<ol style="list-style-type: none"> 1. Whether the setting of software limits is normal. Whether the target position of the motion command for each axis is within the software limits configured by the drive. 2. Whether path is within the operating range defined by the user. 3. Whether the machine dimension is correct. (Please contact original manufacturer)
Solution	Reset alarm

E?827 Group does not exist	
Cause	The designated group does not exist.
Check and Correction	Return it to the dealer or original manufacturer for repairing.
Solution	Reset alarm

E?829 Error in switching the coordinates	
Cause	The coordinates to be switched to do not exist.
Check and Correction	Whether the designated coordinate number is between 0 and 9. If not, please fill in or select the correct coordinate number. Currently, only four coordinates systems of "world", "tool", "user" and "axis" are supported.
Solution	Reset alarm

E?82A Error in switching user coordinates	
Cause	Switching error of the user coordinates
Check and Correction	<ol style="list-style-type: none"> 1. Whether the designated number of user coordinates system has been established or is between 0 and 9. If not, please fill in or select the correct coordinate number. 2. Please use the original software tool to check the coordinates instruction.
Solution	Reset alarm

E?82B Error in switching tool coordinates	
Cause	Switching error of the tool coordinates
Check and Correction	1. Whether the designated number of tool coordinates system has been established or is between 0 and 9. If not, please fill in or select the correct coordinate number. 2. Please use the original software tool to check the coordinates instruction.
Solution	Reset alarm

E?832 Loss of internal communication packet	
Cause	Between the controller and the drive, three continuous losses of the communication packet.
Check and Correction	Return it to the dealer or original manufacturer for repairing.
Solution	Reset alarm

E?833 Error in check code for internal communication	
Cause	Between the controller and the drive, three continuous errors of the communication check code (CRC).
Check and Correction	Return it to the dealer or original manufacturer for repairing.
Solution	Reset alarm

E?841 The arc command is out of boundary	
Cause	The target position of the command issued is out of the operating range.
Check and Correction	Whether the target position of the motion command for each axis is within the configured limits of software.
Solution	Reset alarm

E?842 The arc cannot be formed	
Cause	The input conditions cannot form an arc.
Check and Correction	Whether the input conditions for forming an arc is correct, conditions like 3 points are collinear, the radius is 0, or the centre falls on the circumference cannot form a circle. Please reissue command positions according to conditions that can form a circle.
Solution	Reset alarm

E?843 Arc mode error	
Cause	Setting error of arc parameter mode.
Check and Correction	Return it to the dealer or original manufacturer for repairing.
Solution	Reset alarm

E?851 Time out error in transmission of vision parameters followed by conveyor belt	
Cause	1. Data transmission error 2. Vision system has not been triggered.
Check and Correction	1. Ensure the vision system has been triggered before the robot starts. 2. Check if the configuration and settings for the vision system are correct.
Solution	Reset alarm

E?852 The following speed for conveyor belt exceeds limits	
Cause	The speed of conveyor belt is too fast.
Check and Correction	Reduce the speed of conveyor belt.
Solution	Reset alarm

E?853 Overtime error in transmission of vision parameters followed by conveyor belt	
Cause	Error in setting of number for the user coordinates used in the conveyor belt following application.
Check and Correction	Whether the setting of number for the user coordinates used in the conveyor belt following meets the application specification (it cannot be 0 or larger than 9).
Solution	Reset alarm

E?861 TP handwheel Jog speed too fast	
Cause	TP handwheel Jog speed too fast.
Check and Correction	Please decrease TP handwheel jog speed.
Solution	Alarm reset.

E?862 TP handwheel performing jog	
Cause	TP handwheel performing jog.
Check and Correction	Stop TP handwheel jog first and then perform original movement.
Solution	Alarm reset.

● Axis type:

E?001 Overcurrent	
Cause	<ol style="list-style-type: none"> 1. Short circuit of the drive output 2. Abnormal motor wiring 3. Abnormal IGBT
Check and Correction	<ol style="list-style-type: none"> 1. Whether wiring between the motor and drive has short-circuited, and if circuited, eliminate the short-circuit condition and prevent exposed wiring. 2. Please refer to the wiring sequence in the instruction Manual and check whether the wiring sequence from the motor to the drive is correct and rewire. If the alarm continues, return it to the dealer or original manufacturer for repairing.
Solution	Reset alarm

E?002 Overvoltage	
Cause	<ol style="list-style-type: none"> 1. Input voltage for the main loop is too high 2. Hardware failure on the drive
Check and Correction	<ol style="list-style-type: none"> 1. Whether the input voltage of the main loop is within the rated voltage value; if not, use the correct voltage components or tandem voltage stabilizer to transform the voltage within the rated voltage value. 2. Whether the input voltage of the main loop is within the rated voltage value; if this error continues, please return the drive back to the dealer or original manufacturer for overhauling.
Solution	Reset alarm

E?003 Low voltage	
Cause	<ol style="list-style-type: none"> 1. Input voltage for the main loop is too low 2. The main loop has no source of input voltage 3. Power input error
Check and Correction	<ol style="list-style-type: none"> 1. Use the electric meter to check whether the voltage of the main loop is normal. 2. Please refer to the wiring sequence in the Instruction Manual to check whether the wiring for input voltage on the main loop is normal, if not, please rewire. 3. Whether the power system agrees with the definition of the specification, use the correct voltage elements or tandem voltage stabilizer to transform the voltage within the rated voltage value.
Solution	Clear alarm when voltage restores

E?004 Motor matching error	
Cause	<ol style="list-style-type: none"> 1. Position encoder is loose 2. Motor matching error
Check and Correction	Return it to the dealer or original manufacturer for repairing.
Solution	Reconnect power and clear alarm.

E?005 Retrogradation error	
Cause	1. Wrong retrogradation resistance is chosen or no external retrogradation resistance is connected. 2. Parameter setting error
Check and Correction	Return it to the dealer or original manufacturer for repairing.
Solution	Reset alarm

E?006 Overload	
Cause	1. Continuously exceeding the rated load of the drive 2. Error in wiring for the motor and the encoder 3. Motor drive abnormal
Check and Correction	1. Whether the wiring of U, V, W and the encoder is correct; if not, please rewire correctly. 2. Return the motor to the dealer or original manufacturer for repairing.
Solution	Reset alarm

E?007 Over speed	
Cause	Improper setting for parameter P2-34 (warning conditions for over speed)
Check and Correction	Return it to the dealer or original manufacturer for repairing.
Solution	Reset alarm

E?009 Error in position control is too large	
Cause	1. External load is too large
Check and Correction	Please use within the maximum Payload value or adjust the Payload value.
Solution	Reset alarm

E?011 Encoder abnormal	
Cause	1. Wiring error for the encoder 2. Encoder is loose or the wiring is poor. 3. Encoder is damaged.
Check and Correction	1. Whether the wiring follows the suggested path in the Instruction Manual. 2. Whether the connection of MotorENC. in the drive and the encoder in the motor position is loose; if loose, reconnect MotorENC. of the drive with a position detector.
Solution	Reconnect power and clear alarm.

E?012 Calibration abnormal	
Cause	Current calibration is abnormal
Check and Correction	Return it to the dealer or original manufacturer for repairing.
Solution	Reconnect power and clear alarm.

E?013 Emergency stop	
Cause	Emergency stop switch is pressed.
Check and Correction	Whether the emergency switch is activated. The emergency stop switch is normally off; if activated unintentionally, please turn it off.
Solution	Reset alarm

E?014 Reverse limit abnormal	
Cause	<ol style="list-style-type: none"> 1. The reverse limit switch is activated 2. The servo system is unstable
Check and Correction	Return it to the dealer or original manufacturer for repairing.
Solution	Reset alarm

E?015 Direct limit abnormal	
Cause	<ol style="list-style-type: none"> 1. The direct limit switch is activated 2. The servo system is unstable
Check and Correction	Return it to the dealer or original manufacturer for repairing.
Solution	Reset alarm

E?016 IGBT overheated	
Cause	<ol style="list-style-type: none"> 1. Continuous overloading on the drive 2. Short circuit upon output from the drive
Check and Correction	<ol style="list-style-type: none"> 1. Check whether the load is too large, and use within the maximum Payload value or adjust the Payload value. 2. Check the drive output wiring to ensure the wiring is correct.
Solution	Reset alarm

E?017 Memory abnormal	
Cause	<ol style="list-style-type: none"> 1. Reference data write-in error or parameter error, which occurs at factory reset for parameters due to error in setting of drive types. 2. Drive memory abnormal 3. ROM data is damaged, if error occurs during power transmission, it is usually due to damage on ROM data or no data available in the ROM. Please return it to the dealer or original manufacturer for repairing.
Check and Correction	Return it to the dealer or original manufacturer for repairing.
Solution	Reset alarm

E?018 Detector output abnormal	
Cause	1. Encoder error 2. The output pulse exceeds a permissible range for the hardware.
Check and Correction	Return it to the dealer or original manufacturer for repairing.
Solution	Reset alarm

E?019 Serial communication abnormal between controller and drive	
Cause	1. Improper settings for communication parameters 2. Incorrect communication address 3. Incorrect communication value
Check and Correction	1. Reset to the factory setting 2. Or return it to the dealer or original manufacturer for repairing.
Solution	Reset alarm

E?020 Overtime in serial communication between controller and drive	
Cause	The drive has not received communication command for a long time.
Check and Correction	Check whether the communication cable is loose or broken to ensure correct wiring.
Solution	Reset alarm

E?022 Power abnormal on the main loop	
Cause	Power abnormal on the main loop
Check and Correction	1. Whether RS power cable is loose or non-conductive. 2. Connect the power correctly. If power supply is normal but alarm remains, return the drive to the dealer or manufacturer for repairing.
Solution	Reset alarm

E?023 Advanced overload warning	
Cause	Advanced overload warning
Check and Correction	1. Whether the use of overloading. Please refer to the Corrective Action for E?006
Solution	Reset alarm

E?024 Error in Initial magnetic field for the internal encoder	
Cause	Error in initial magnetic field for the encoder (error in the magnetic field positions U, V and W)
Check and Correction	Return it to the dealer or original manufacturer for repairing.
Solution	Reconnect power and clear alarm.

E?025 Internal error on the encoder	
Cause	1. Internal error on the encoder (internal memory error and error in internal counting). 2. The motor rotates due to mechanical inertia or other reasons when it is connected to the power.
Check and Correction	Return it to the dealer or original manufacturer for repairing.
Solution	Reconnect power and clear alarm.

E?026 Error in reliability of internal data for the encoder	
Cause	Encoder error (three continuous errors in internal data)
Check and Correction	Return it to the dealer or original manufacturer for repairing.
Solution	Reconnect power and clear alarm.

E?027 Error in internal reset for the encoder	
Cause	Encoder chip reset
Check and Correction	Return it to the dealer or original manufacturer for repairing.
Solution	Reconnect power and clear alarm.

E?028 High voltage on the encoder or internal error on the encoder	
Cause	1. Over-voltage on battery 2. Internal error of the encoder
Check and Correction	1. Whether the drive has a charging circuit and whether battery installation (voltage >3.8 V) is abnormal. Please use an electric meter to check whether the voltage is higher than 3.8V.
Solution	Reconnect power and clear alarm.

E?029 Gray code error	
Cause	Error in absolute position of one-loop
Check and Correction	Reconnect the power supply and run the motor to see if alarm reappears, if it remains, return it to the dealer or original manufacturer for repairing.
Solution	Reconnect power and clear alarm.

E?030 Motor collision error	
Cause	1. Whether anti-collision function for the motor is activated. 2. Return it to the dealer or original manufacturer for repairing.
Check and Correction	Reconnect the power supply and run the motor to see if alarm reappears, if it remains, replace the encoder.
Solution	Reconnect power and clear alarm.

E?031 Detection on disconnection of the motor power cable	
Cause	Disconnection of the motor power cable
Check and Correction	Whether the motor power cables (U, V, W, GND) are disconnected, please connect the cables correctly according to the Instruction Manual and ground them correctly.
Solution	Reconnect power and clear alarm.

E?034 Error in internal communication for the encoder	
Cause	Error in internal communication for the encoder
Check and Correction	Whether the battery wiring is loose; if loose, reconnect the battery correctly and turn on the power again
Solution	Reconnect power and clear alarm.

E?044 Warning on usage of the drive functions	
Cause	Warning on usage of the drive functions
Check and Correction	Return it to the dealer or original manufacturer for repairing.
Solution	Reconnect power and clear alarm.

E?060 Loss of absolute position	
Cause	<ol style="list-style-type: none"> 1. Battery voltage is too low 2. Replace the battery when power of the drive control is turned off 3. The initialization on coordinates for the absolute position has not been completed after activating the absolute function. 4. Poor contact or disconnection on the circuit for supply of battery power. 5. Change of the ratio on the electronic gear.
Check and Correction	<ol style="list-style-type: none"> 1. Whether the battery voltage is lower than 2.8V. 2. Do not change or remove the battery when the drive control power is turned off. 3. Reset the coordinates for the absolute position after completing the initialization on the coordinates for the absolute position and the zero return procedure. 4. (1) Whether the battery installation and wiring is correct. (2) Check the encoder wiring (3) Check the wiring between the external battery holder and the drive <p>Corrective action: Repeat the zero return procedure</p>
Solution	Reconnect power and clear alarm.

E?061 Low voltage on the encoder	
Cause	Battery voltage is too low.
Check and Correction	<ol style="list-style-type: none"> 1. Whether the voltage on panel battery is lower than 3.1V (provisional specification). 2. Whether the battery voltage is lower than 3.1V (provisional specification); if lower, please replace the battery with power ON for the drive control.
Solution	Auto-clear

E?062 Absolute position laps overflow	
Cause	The stroke is out of range.
Check and Correction	Return it to the dealer or original manufacturer for repairing.
Solution	Reconnect power and clear alarm.

E?067 Encoder temperature alarm	
Cause	Temperature of the encoder is too high (85~100 °C)
Check and Correction	Return it to the dealer or original manufacturer for repairing.
Solution	Reconnect power and clear alarm.

E?069 Motor type error	
Cause	Activation of absolute function by the incremental motor is not allowed.
Check and Correction	Whether the motor is of incremental motor or absolute encoder.
Solution	Reconnect power and clear alarm.

E?06A Loss of absolute position	
Cause	The initialization on coordinates for the absolute position has not been completed after activating the absolute function.
Check and Correction	<ol style="list-style-type: none"> 1. Reset the coordinates for the absolute position after completing the initialization on the coordinates for the absolute position and the zero return procedure. 2. Return it to the dealer or original manufacturer for repairing.
Solution	Reconnect power and clear alarm.

E?070 Incomplete encoder processing	
Cause	Related commands are not completed when the encoder conducts Barcode write-in or relevant actions.
Check and Correction	Return it to the dealer or original manufacturer for repairing.
Solution	Reconnect power and clear alarm.

E?099 EEPROM needs updating	
Cause	EEPROM needs updating
Check and Correction	Return it to the dealer or original manufacturer for repairing.
Solution	Reconnect power and clear alarm.

E?111 DMCNET packet receiver overflows	
Cause	More than 2 packets are received within 1ms.
Check and Correction	Return it to the dealer or original manufacturer for repairing.
Solution	Reconnect power and clear alarm.

E?185 DMCNET Bus hardware abnormal	
Cause	DMCNET Bus hardware abnormal or loss of communication packet
Check and Correction	Return it to the dealer or original manufacturer for repairing.
Solution	Reconnect power and clear alarm.

E?201 Initial error of DMCNET data	
Cause	Initial error of DMCNET data
Check and Correction	Return it to the dealer or original manufacturer for repairing.
Solution	Reconnect power and clear alarm.

E?235 Position command overflows	
Cause	1. When temporary register for the feedback position overflows; 2. When the zero return is triggered, but the zero return procedure is not completed; 3. When E?060 and E?062 occur.
Check and Correction	Implement the zero return procedure.
Solution	Reconnect power and clear alarm.

E?245 Positioning overtime	
Cause	Positioning overtime for the position mode .
Check and Correction	Return it to the dealer or original manufacturer for repairing.
Solution	None.

E?283 Drive direct limit	
Cause	Exceeding software direct limit.
Check and Correction	Whether the position exceeds the value of P5-09. Please set the limit according to actual conditions; if the position doesn't exceed the limit, please set the maximum:2147483648.
Solution	Reset alarm.

E?285 Drive reverse limit	
Cause	Exceeding software reverse limit.
Check and Correction	Whether the position exceeds the value of P5-09. Please set the limit according to actual conditions; if the position doesn't exceed the limit, please set the maximum:-2147483648.
Solution	Reset alarm.

Note: Direct and reverse limits for the software are determined according to the position commands and not the actual feedback positions, because the commands always arrive before the feedback. When the limits play a protective role, the actual position may not have exceeded the limit; therefore, desired effect can be achieved by setting appropriate deceleration time. Please refer to the description of Parameter P5-03

E?289 Position counter overflows	
Cause	Position counter overflows.
Check and Correction	Do not make any modification on the original machine if this alarm occurs; return it back to the original manufacturer directly.
Solution	None.

E?301 DMCNET synchronizing signal failed	
Cause	Failure on transmission of synchronizing signal.
Check and Correction	1. Whether the quality of communication line is poor. 2. Return it to the dealer or original manufacturer for repairing.
Solution	Reset alarm

E?302 DMCNET synchronizing signal is too fast	
Cause	Synchronizing signal is too fast.
Check and Correction	Return it to the dealer or original manufacturer for repairing.
Solution	Reset alarm

E?303 DMCNET synchronizing signal overtime	
Cause	Synchronizing signal overtime
Check and Correction	Return it to the dealer or original manufacturer for repairing.
Solution	Reset alarm.

E?304 DMCNET IP command invalid	
Cause	The IP mode operation time is too long.
Check and Correction	Return it to the dealer or original manufacturer for repairing.
Solution	Reset alarm.

E?500 STO function is activated	
Cause	Safety function STO is activated.
Check and Correction	Safety function STO is manually activated; please check the activating cause.
Solution	Reset alarm.

E?501 STO_A lost	
Cause	STO_A loses enabling signal or STO_A and STO_B have not been synchronized for more than 1 second.
Check and Correction	Whether the STO_A wiring is correct.
Solution	Reset alarm.

E?502 STO_B lost	
Cause	STO_B loses enabling signal or STO_A and STO_B have not been synchronized for more than 1 second.
Check and Correction	Whether the STO_B wiring is correct.
Solution	Reset alarm.

E?503 STO_error	
Cause	STO self-diagnosis error.
Check and Correction	Whether STO_A and STO_B correctly connected.
Solution	Reset alarm.

E?555 Drive failure	
Cause	Drive processor abnormal.
Check and Correction	Do not make any modification on the original machine if this alarm occurs; return it to the original manufacturer directly.
Solution	None.

Note: If abnormal alarm code that isn't listed above, please notify the original manufacturer.

● Control type:

EC001 PLC timeout	
Cause	1. PLC program too big, execution time too long. 2. Debug operation.
Check and Correction	1. Confirm PLC Debug is closed.
Solution	Alarm reset.

EC002 PLC Image load failed	
Cause	The library version in the PLC Image does not match with the system.
Check and Correction	Check whether the controller parameter P1-01 is 1; if so, version mismatch is caused by firmware update. Please update to the same version of PLC Image.
Solution	Alarm reset.

EC003 PLC Exception																																											
Cause	PLC execution error.																																										
Check and Correction	Please refer to the following error message for troubleshooting.																																										
	<table border="1"> <thead> <tr> <th>Error Message</th> <th>Exception Code</th> </tr> </thead> <tbody> <tr> <td>PlcExcNon</td> <td>0</td> </tr> <tr> <td>ExcOutOfMemory</td> <td>1</td> </tr> <tr> <td>ExcDivisionByZero</td> <td>2</td> </tr> <tr> <td>ExcIndexOutOfRange</td> <td>3</td> </tr> <tr> <td>ExcIllegalCast</td> <td>4</td> </tr> <tr> <td>ExcStackOverflow</td> <td>5</td> </tr> <tr> <td>ExcNullReference</td> <td>6</td> </tr> <tr> <td>ExcMissingMethod</td> <td>7</td> </tr> <tr> <td>ExcThreadCreation</td> <td>8</td> </tr> <tr> <td>ExcThreadAbort</td> <td>9</td> </tr> <tr> <td>ExcSynchronizationLockException</td> <td>10</td> </tr> <tr> <td>ExcBreakpointIllegal</td> <td>11</td> </tr> <tr> <td>ExcBreakpoint</td> <td>12</td> </tr> <tr> <td>ExcExecutionEngine</td> <td>13</td> </tr> <tr> <td>ExcExternal</td> <td>16</td> </tr> <tr> <td>PlcExcString</td> <td>32</td> </tr> <tr> <td>PlcExcWatchDogExceeded</td> <td>33</td> </tr> <tr> <td>PlcExcMaximumCpuLoadExceeded</td> <td>34</td> </tr> <tr> <td>PlcExcSystem</td> <td>35</td> </tr> <tr> <td>PlcExcEnd</td> <td>36</td> </tr> </tbody> </table>	Error Message	Exception Code	PlcExcNon	0	ExcOutOfMemory	1	ExcDivisionByZero	2	ExcIndexOutOfRange	3	ExcIllegalCast	4	ExcStackOverflow	5	ExcNullReference	6	ExcMissingMethod	7	ExcThreadCreation	8	ExcThreadAbort	9	ExcSynchronizationLockException	10	ExcBreakpointIllegal	11	ExcBreakpoint	12	ExcExecutionEngine	13	ExcExternal	16	PlcExcString	32	PlcExcWatchDogExceeded	33	PlcExcMaximumCpuLoadExceeded	34	PlcExcSystem	35	PlcExcEnd	36
	Error Message	Exception Code																																									
	PlcExcNon	0																																									
	ExcOutOfMemory	1																																									
	ExcDivisionByZero	2																																									
	ExcIndexOutOfRange	3																																									
	ExcIllegalCast	4																																									
	ExcStackOverflow	5																																									
	ExcNullReference	6																																									
	ExcMissingMethod	7																																									
	ExcThreadCreation	8																																									
	ExcThreadAbort	9																																									
	ExcSynchronizationLockException	10																																									
	ExcBreakpointIllegal	11																																									
	ExcBreakpoint	12																																									
	ExcExecutionEngine	13																																									
	ExcExternal	16																																									
	PlcExcString	32																																									
	PlcExcWatchDogExceeded	33																																									
PlcExcMaximumCpuLoadExceeded	34																																										
PlcExcSystem	35																																										
PlcExcEnd	36																																										
Solution	Alarm reset.																																										

EC004 Motion module failed	
Cause	Abnormal movement module function.
Check and Correction	If this alarm occurred, do not make any modifications to the original machine and send it back to the manufacturer directly.
Solution	None.

EC005 Controller failed	
Cause	Abnormal controller function.
Check and Correction	If this alarm occurred, do not make any modifications to the original machine and send it back to the manufacturer directly.
Solution	None.

EC004 Motion module failed	
Cause	Abnormal movement module function.
Check and Correction	If this alarm occurred, do not make any modifications to the original machine and send it back to the manufacturer directly.
Solution	None.

EC006 Continuous 30 second write in alarm	
Cause	Write in operation executed for 30 seconds continually without interruptions.
Check and Correction	Check whether the logic of the PLC and RL program or Modbus operation has errors that caused continuous write in. If it occurs repeatedly, it is recommended to remove all external devices and restore original PLC settings and debug step by step.
Solution	Alarm reset.

EC007 DMCNET device setting mismatch	
Cause	DMCNET power on scan results does not match with the maintain power parameter settings.
Check and Correction	Please check the connection status of the DMCNET device and confirm whether the controller parameter P3-31~P3-42 settings matches the current DMCNET external device.
Solution	Alarm reset, to change settings please scan again and save the power maintain parameter.

EC009 Robot Type mismatch	
Cause	The Robot Type set in the parameter does not match the one loaded by the current movement module.
Check and Correction	<ol style="list-style-type: none"> 1. Confirm the firmware version; is it an updated firmware (downgraded or failed) that caused parameters P1-00 and P0-03 to be inconsistent. 2. Reset parameter P1-00, confirm that the current firmware version supports this type, disconnect the power and restart.
Solution	Reconnect the power and clear.

E1998 Operation mode not started	
Cause	Operation mode not started, please confirm the reason or System DI4 and DI5 contact are not connected.
Check and Correction	Please conform the System DI4 and DI5 contacts of the operation mode, and restart the controller.
Solution	Alarm reset.

Note: If abnormal alarm code that isn't listed above, please notify the original manufacturer.



Smarter. Greener. Together.

Industrial Automation Headquarters

Delta Electronics, Inc.

Taoyuan Technology Center
No.18, Xinglong Rd., Taoyuan Dist.,
Taoyuan City 33068, Taiwan
TEL: 886-3-362-6301 / FAX: 886-3-371-6301

Asia

Delta Electronics (Jiangsu) Ltd.

Wujiang Plant 3
1688 Jiangxing East Road,
Wujiang Economic Development Zone
Wujiang City, Jiang Su Province,
People's Republic of China (Post code: 215200)
TEL: 86-512-6340-3008 / FAX: 86-769-6340-7290

Delta Greentech (China) Co., Ltd.

238 Min-Xia Road, Pudong District,
ShangHai, P.R.C.
Post code : 201209
TEL: 86-21-58635678 / FAX: 86-21-58630003

Delta Electronics (Japan), Inc.

Tokyo Office
2-1-14 Minato-ku Shibadaimon,
Tokyo 105-0012, Japan
TEL: 81-3-5733-1111 / FAX: 81-3-5733-1211

Delta Electronics (Korea), Inc.

1511, Byucksan Digital Valley 6-cha, Gasan-dong,
Geumcheon-gu, Seoul, Korea, 153-704
TEL: 82-2-515-5303 / FAX: 82-2-515-5302

Delta Electronics Int'l (S) Pte Ltd

4 Kaki Bukit Ave 1, #05-05, Singapore 417939
TEL: 65-6747-5155 / FAX: 65-6744-9228

Delta Electronics (India) Pvt. Ltd.

Plot No 43 Sector 35, HSIIDC
Gurgaon, PIN 122001, Haryana, India
TEL : 91-124-4874900 / FAX : 91-124-4874945

Americas

Delta Products Corporation (USA)

Raleigh Office
P.O. Box 12173, 5101 Davis Drive,
Research Triangle Park, NC 27709, U.S.A.
TEL: 1-919-767-3800 / FAX: 1-919-767-8080

Delta Greentech (Brasil) S.A

Sao Paulo Office
Rua Itapeva, 26 - 3° andar Edificio Itapeva One-Bela Vista
01332-000-São Paulo-SP-Brazil
TEL: +55 11 3568-3855 / FAX: +55 11 3568-3865

Europe

Delta Electronics (Netherlands) B.V.

Eindhoven Office
De Witbogt 20, 5652 AG Eindhoven, The Netherlands
TEL: +31 (0)40-8003800 / FAX: +31 (0)40-8003898

*We reserve the right to change the information in this catalogue without prior notice.

Edition March, 2016