

Nidec

FLEXWAVE

An evolution in strain wave gear technology



NIDEC-SHIMPO CORPORATION

FLEXWAVE

Achieving new heights in compact, fine precision gear technology

NIDEC-SHIMPO has had a long and storied history supplying the leading robotics and machine tool manufacturers in Japan. Our loyal customers within these industries strongly urged us to develop our own strain wave gear technology, and leverage our primary competencies – modularity and flexibility of the core design and consistent production in mass volume – to help them become more competitive in the global marketplace. After extensive effort to refine strain wave gear technology and to manufacture at a level that exceeds our customers' expectations, NIDEC-SHIMPO is proud to introduce our new **FLEXWAVE** technology.

The **NIDEC-SHIMPO FLEXWAVE** is a very compact reduction mechanism that achieves zero backlash, as well as exceptional accuracy and repeatability. The **FLEXWAVE** consists of three major internal elements – the elliptical wave generator subassembly, the flexible cup gear, and the inner ring gear. The elasticity properties of the cup gear and the teeth differential between the cup gear and the inner ring gear result in the unique reduction characteristics. When compared to other reduction technologies, the **FLEXWAVE** offers the following advantages;

- › *Near Zero backlash*
- › *High efficiency ratings*
- › *High reduction ratios in a compact footprint*
- › *Exceptional repeatability and torsional stiffness*
- › *Extremely light weight with superior torque density*

These characteristics enable the **FLEXWAVE** to be the superior choice when sizing and selecting the proper reduction technology for **ROBOTICS, MEDICAL EQUIPMENT, SEMICONDUCTOR** and **CIRCUIT MANUFACTURING, MACHINE TOOLS** or any **ASSEMBLY AUTOMATION** applications requiring fine positioning.

Index

An Exposé on Strain Wave Gear Technology 2

Component Level Detail and Reduction Ratio 3

Model Code and Basic Performance Specifications 4

Closed Housing Style

Component Sub-assembly 5



Complete Unit Assembly 6



Open Housing Style

Simple Contained Assembly 7



Complete Unit Assembly (Hollow shaft) 8



Complete Unit Assembly (Input shaft) 9



An Exposé on Strain Wave Gear Technology

Reduction Mechanism

Strain wave gear technology centers on the elasticity and flexibility properties of a uniquely shaped metal structure. The strain wave gear set has three key elements; the elliptical wave generator subassembly, the flexible cup gear, and the inner ring gear.

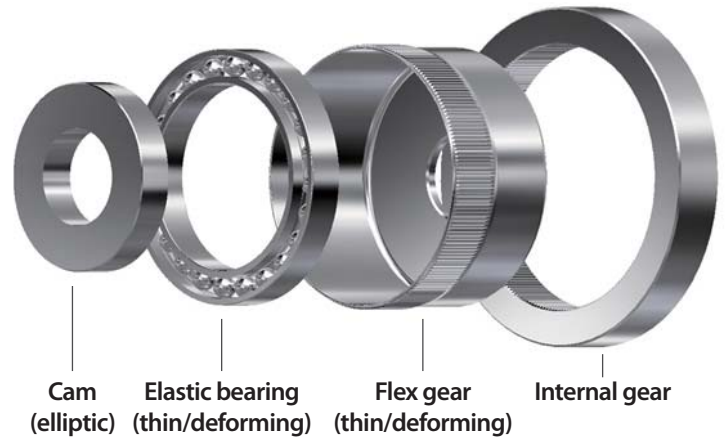

- › *The elliptical wave generator subassembly is comprised of two components: an elliptical shaped disk and an outer ball bearing. The disk is inserted into the bearing, giving the bearing an elliptical shape as well. The wave generator assembly is the input section of the gear set.*
- › *The flexible cup gear is the internal component that relies on unique elasticity properties to accommodate an elliptical deformation pattern. The sides of the cup gear are very thin, but the bottom of the cup gear is thick and rigid. This results in significant flexibility of the walls at the open end of the cup; but then the cup gear exhibits high rigidity at the closed end of the cup. Teeth are positioned radially around the perimeter of the open end of this cup gear.*
- › *The flexible cup gear fits very tightly over the wave generator subassembly. When the wave generator is rotated, the cup gear deforms to the shape of a rotating ellipse but does not rotate with the wave generator.*
- › *The inner ring gear is a rigid circular ring with teeth located on the interior perimeter. The wave generator and cup gear are placed inside this inner ring gear, meshing the teeth together. Because the cup gear has a deformed elliptical shape, the teeth will only mesh in two regions 180 degrees from each other, along the axis of the ellipse.*
- › *As the wave generator subassembly rotates, the group of teeth of the cup gear that are engaged with those of the inner ring gear changes. The major axis of the cup gear actually rotates with the wave generator therefore; the points where the teeth mesh revolve around the center point at the same rate as the wave generator.*
- › *The reduction is accomplished through a tooth count differential between the cup gear and the inner ring gear. For every full rotation of the wave generator subassembly, the cup gear rotates a minor amount backward because it has less teeth than the inner ring gear.*

Reduction Ratio

The rotation the wave generator subassembly results in a much slower rotation of the cup gear in the opposite direction. For a strain wave gearing mechanism, the gearing reduction ratio can be calculated from the number of teeth on each gear:

As an example, if there are 202 teeth on the inner ring gear and 200 on the cup gear, the reduction ratio is

$$(200 - 202)/200 = -0.01$$

Therefore the cup rotates at 1/100 of the speed of the wave generator assembly and in the opposite direction. This method of reduction permits a variety of ratios to be set without changing overall gear set shape, increasing its weight, or adding reduction stages. The variety of reduction ratios possible is restricted by the structural tooth size limitation for any given configuration.

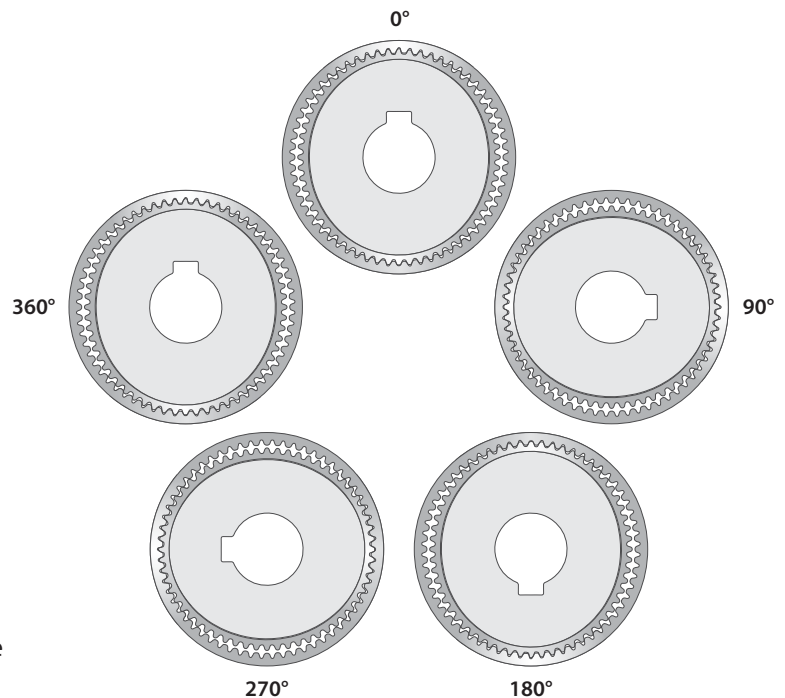

Component Level Detail and Reduction Ratio

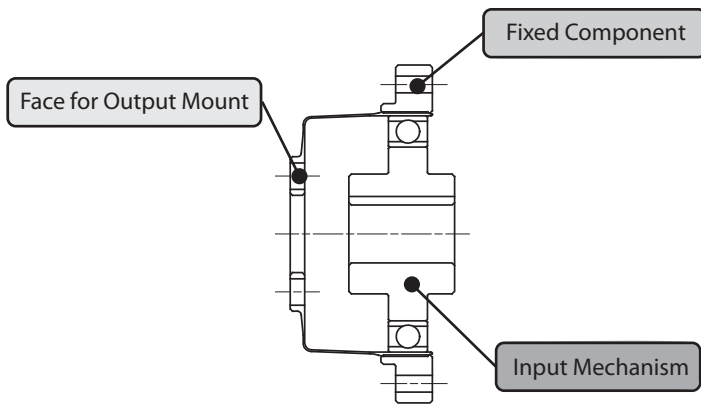
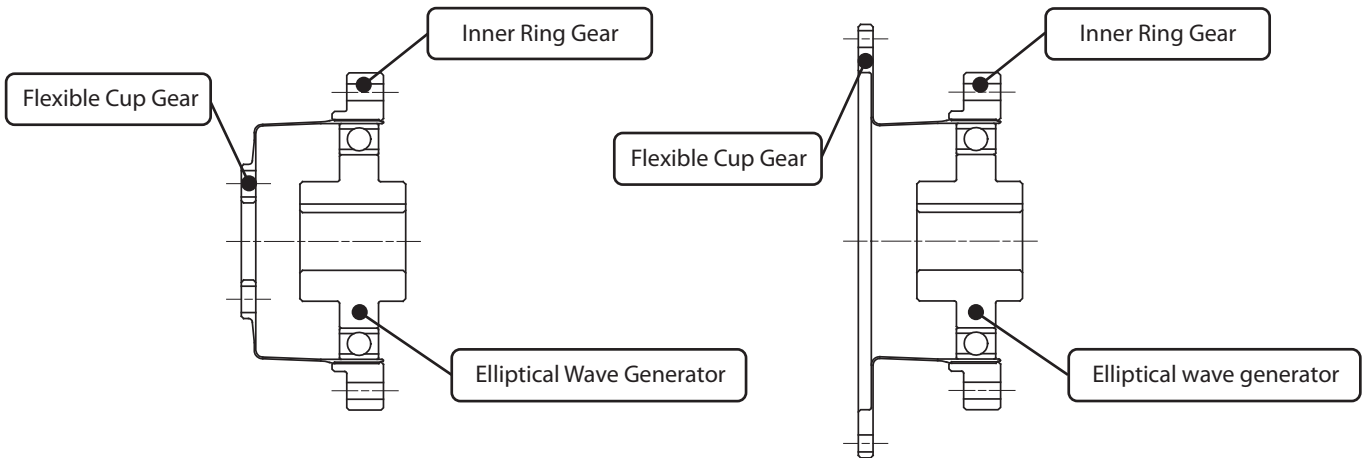

$$\text{Reduction ratio} = \frac{-1}{R}$$

Note: The input and output rotation directions are opposite

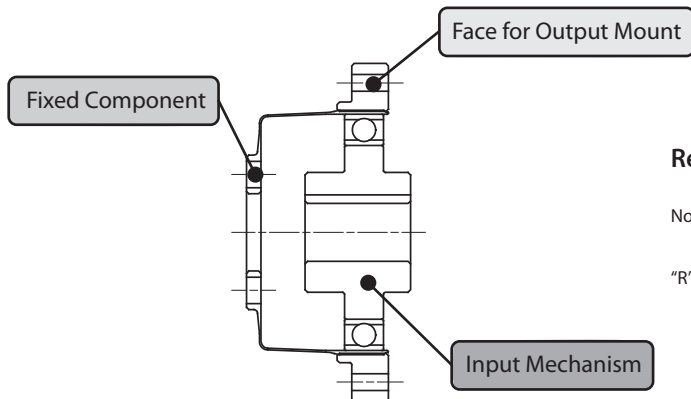

$$\text{Reduction ratio} = \frac{1}{R+1}$$

Note: The input and output rotation directions are same

"R" is the ratio. Please refer to "Reducer Specifications" in the next page

Model Code and Basic Performance Specifications

WP	C	-	35	-	50	-	CN	-	**
* Specifications: Input shaft diameter, etc.									
Code: CN, CF, SN, SNH, SNJ									
Ratio: 50, 80, 100, 120									
Size: 35, 42, 50, 63, 80									
C: Component type S: Simple unit type U: Unit type									
Model name: WP series									

Frame Size

Size/Ratio	1/50	1/80	1/100	1/120
35				
42				
50				
63				
80				

Reducer Specifications

Size	Ratio	Nominal Output Torque *1	Maximum Output Torque *2	Emergency Stop Torque *3	Nominal Input Speed *4	Maximum Input Speed *5	Permitted Axial Load *6
		Nm	Nm	Nm	r/min	r/min	×10-4kgm ²
35	50	7	23	46	3000	8500	0.027
	80	9	27	55			
	100	9	32	63			
42	50	21	44	91	3000	7300	0.055
	80	26	50	102			
	100	28	63	129			
	120	28	63	129			
50	50	33	73	127	3000	6500	0.158
	80	40	86	149			
	100	47	96	172			
	120	47	96	172			
63	50	51	127	242	3000	5600	0.385
	80	66	142	266			
	100	70	163	295			
	120	70	163	295			
80	50	89	253	447	3000	4800	1.03
	80	122	316	590			
	100	142	346	673			
	120	142	346	673			

*1) The maximum value allowable at the input rotation speed of 2000r/min

*2) The maximum torque when starting and stopping

*3) The maximum torque when it receives shock

*4) The maximum average input speed

*5) The maximum average input torque

*6) Values depend on the input shaft diameter, etc.

Closed Style - Component Sub-assembly

WPC-□-□-CN

WPC-□-□-CF

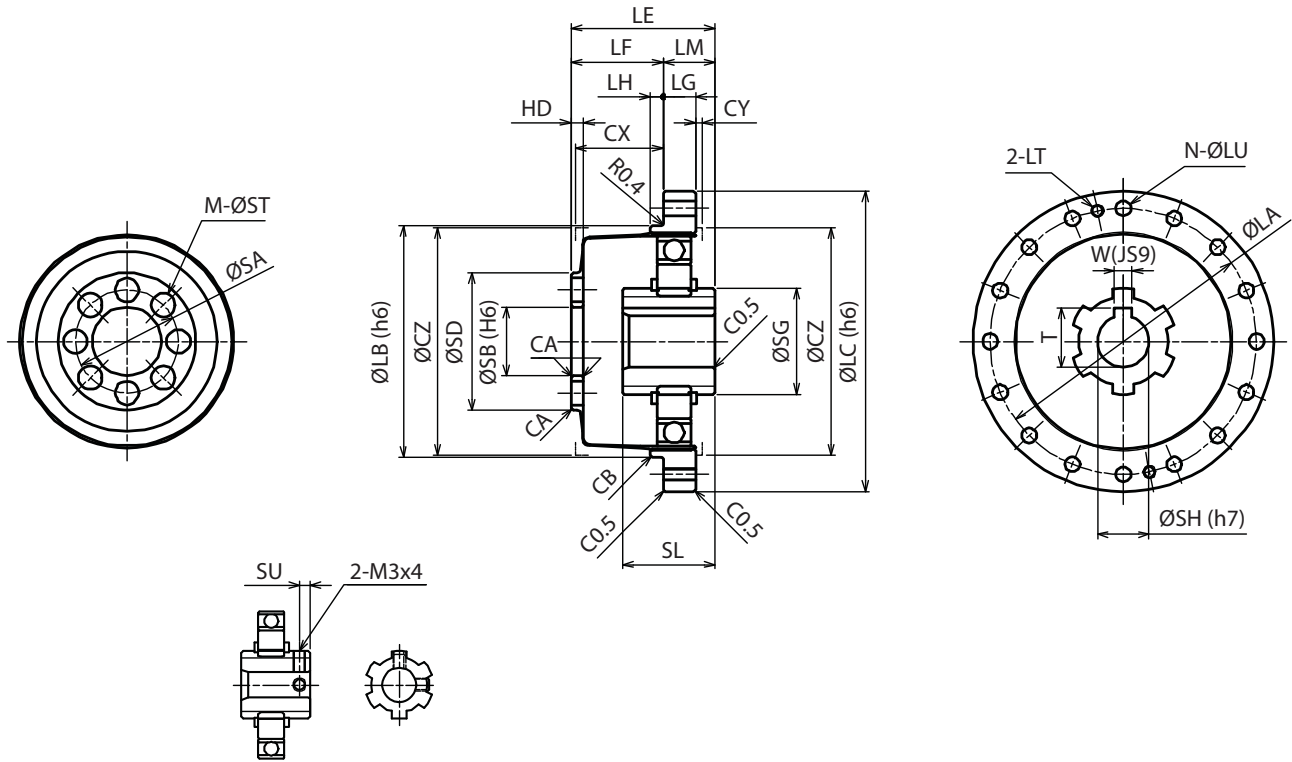

INPUT SHAFT FOR 35 & 42

Size	LA	LB	LC	N*1	LU	LT	LE	LF	LG	LH	LM	SG	SH	SL	W
35	44	38	50	8 (6)	3.5	M3	28.5	17.5	6	2	11	15.8	6	18.5	-
42	54	48	60	16 (12)	3.5	M3	32.5	20	6.5	2.5	12.5	15.8	8	20.7	-
50	62	54	70	16 (12)	3.5	M3	33.5	21.5	7.5	3	12	24.8	12	21.5	4
63	75	67	85	16 (12)	4.5	M4	37	24	10	3	13	27.8	14	21.6	5
80	100	90	110	16 (12)	5.5	M5	44	28	14	3	16	27.8	14	23.6	5

Size	T	SU	SA	SB	SD	M	ST	HD	CA	CB	CX	CY	CZ
35	-	2.5	17	11	23.5	6	4.5	2.4	C0.5	C0.3	17	1	38
42	-	3	19	10	27	6	5.5	3	C0.5	C0.3	19	1	45
50	13.8	-	24	16	32	8	5.5	3	C0.5	C0.5	20.5	1.5	53
63	16.3	-	30	20	40	8	6.5	3	C0.5	C0.5	23	1.5	66
80	16.3	-	40	26	52	8	8.8	3.2	C0.5	C0.5	26.8	1.5	86

*1) -CN and -CF are different in dimensions. The -CF value is shown in parentheses

*2) For details in the input section, check the drawings

Closed Style - Complete Unit Assembly

WPU-□-□-CN

WPU-□-□-CF

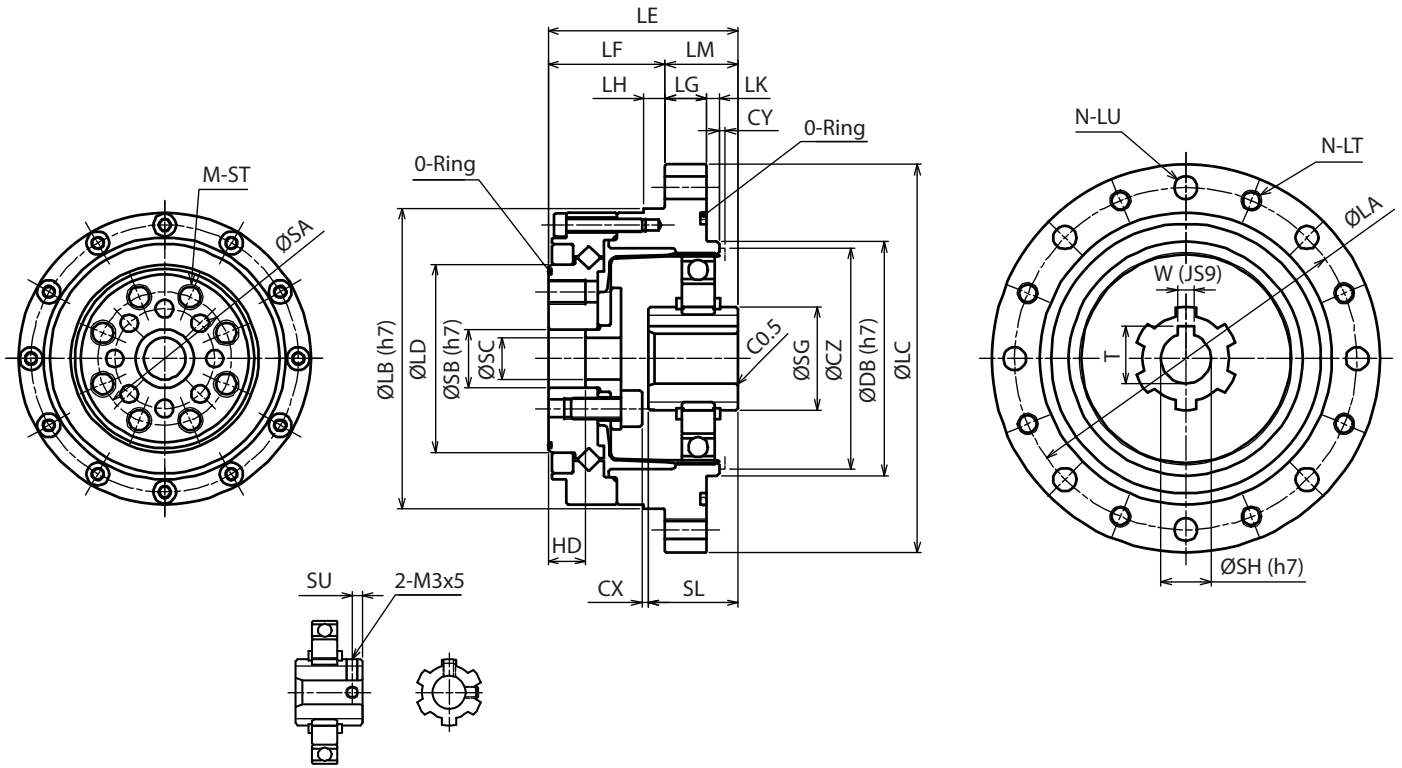

INPUT SHAFT FOR 35 & 42

Size	LA	LB	LC	LD	N *1	LT	LU	LE	LF	LG	LH	LK	LM	DB	SG
35	65	56	73	31	8 (6)	M4	4.5	41	27	7	3.5	2	14	38	15.8
42	71	63	79	38	8 (6)	M4	4.5	45	29	8	4	2	16	48	15.8
50	82	72	93	45	8 (6)	M5	5.5	45.5	28	10	5	3	17.5	56	24.8
63	96	86	107	58	10 (8)	M5	5.5	52	36	10	5	3	16	67	27.8
80	125	113	138	78	12	M6	6.5	62	45	12	5	3	17	90	27.8

Size	SH	SL	W	T	SU	SA	SB	SC	M	ST	HD	CX	CY	CZ
35	6	18.5	-	-	2.5	23	11	8	6	M4x8	9.5	1.6	1	38
42	8	20.7	-	-	3	27	10	7	6	M5x8	9.5	1.3	1	45
50	12	21.5	4	13.8	-	32	14	10	8	M6x9	9	1.5	1.5	53
63	14	21.6	5	16.3	-	42	20	15	8	M8x10	12	3.4	1.5	66
80	14	23.6	5	16.3	-	55	26	20	8	M10x12	15	5.2	1.5	86

*1) -CN and -CF are different in dimensions. The -CF value is shown in parentheses

*2) For details in the input section, check the drawings

Open Style - Simple Contained Assembly

WPS-□-□-SN

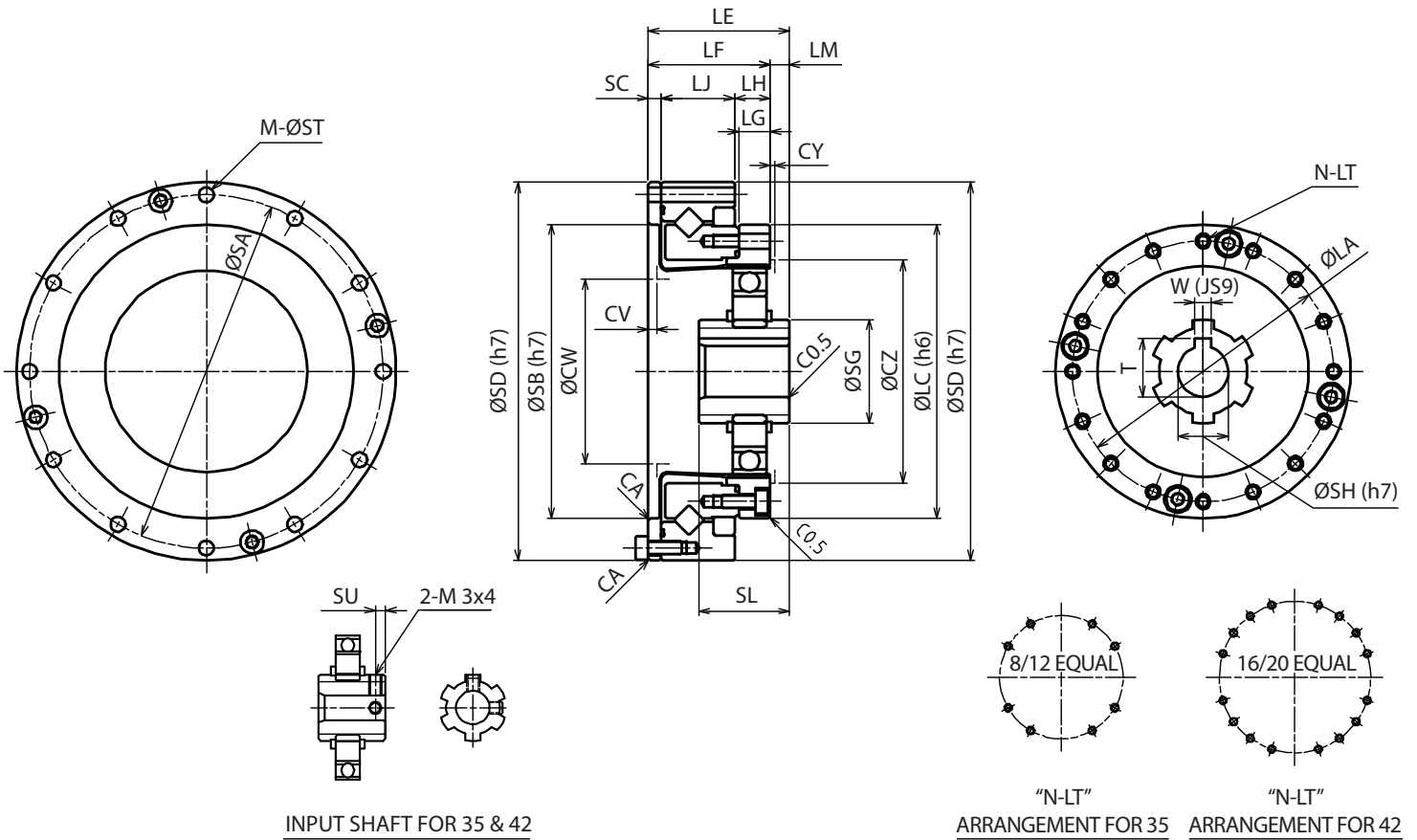

Size	LA	LC	LE	LF	LG	LH	LJ	LM
35	44	50	28.5	23.5	6	7	14.1	5
42	54	60	32.5	26.5	6.5	8	16	6
50	62	70	33.5	29	7.5	8.5	17.5	4.5
63	77	85	37	34	10	12	18.7	3
80	100	110	44	42	14	15	23.4	2

Size	SG	SH	SL	W	T	SU	SA	SB
35	15.8	6	18.5	-	-	2.5	64	48
42	15.8	8	20.7	-	-	3	74	60
50	24.8	12	21.5	4	13.8	-	84	70
63	27.8	14	21.6	5	16.3	-	102	88
80	27.8	14	23.6	5	16.3	-	132	114

Size	SC	SD	M	ST	CA	CY	CZ	CV	CW	N	LT
35	2.4	70	8	3.5	C0.3	1	38	1.6	31	8	M3×5, φ3.5×6
42	3	80	12	3.5	C0.3	1	45	2	37	16	M3×6, φ3.5×6.5
50	3	90	12	3.5	C0.3	1.5	53	2	44	16	M3×6, φ3.5×7.5
63	3.3	110	12	4.5	C0.3	1.5	66	2	56	16	M4×7, φ4.5×10
80	3.6	142	12	5.5	C0.5	1.5	86	2	72	16	M5×8, φ5.5×14

*1) For details in the input section, check the drawings

Open Style - Complete Unit Assembly (Hollow shaft)

WPU-□-□-SNH

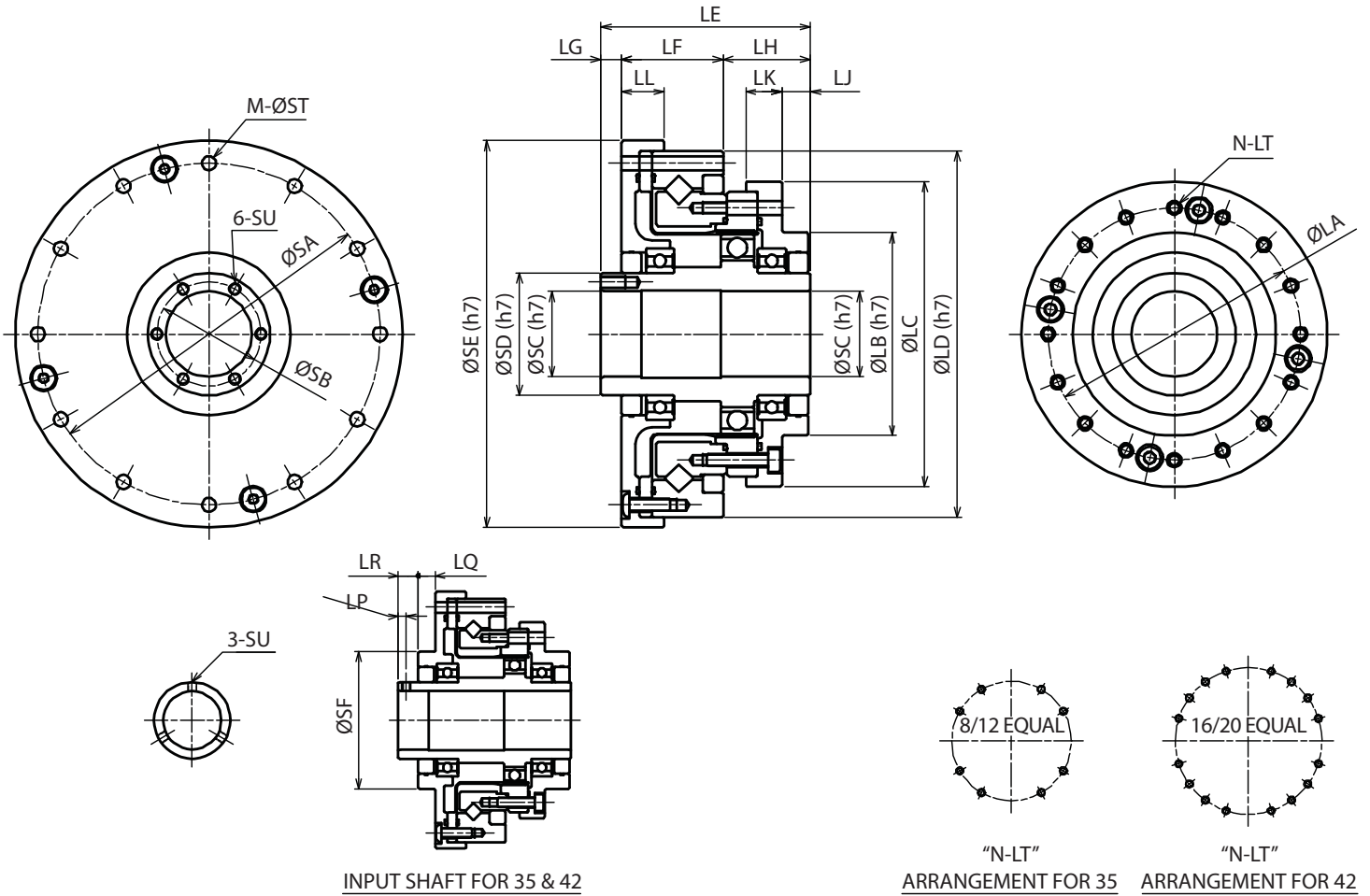

Size	LA	LB	LC	LD	LE	LF	LG	LH	LJ	LK	LL	LP	LQ	LR
35	44	36	54	70	52.5	20.5	12	20	7.5	8	9	2.5	5.5	6.5
42	54	45	64	80	56.5	23	12	21.5	8.5	8.5	10	2.5	5.5	6.5
50	62	50	75	90	51.5	25	5	21.5	7	9	10.5	-	-	-
63	77	60	90	110	55.5	26	6	23.5	6	8.5	10.5	-	-	-
80	100	85	115	142	65.5	32	7	26.5	5	9.5	12	-	-	-

Size	SA	SB	SC	SD	SE	SF	M	ST	SU	N	LT
35	64	-	14	20	74	36	8	3.5	M3	8	M3×5, φ3.5×11.5
42	74	-	19	25	84	45	12	3.5	M3	16	M3×6, φ3.5×12
50	84	25.5	21	30	95	-	12	3.5	M3×6	16	M3×6, φ3.5×13.5
63	102	33.5	29	38	115	-	12	4.5	M3×6	16	M4×7, φ4.5×15.5
80	132	40.5	36	45	147	-	12	5.5	M3×6	16	M5×8, φ5.5×20.5

Open Style - Complete Unit Assembly (Input shaft)

WPU-□-□-SNJ

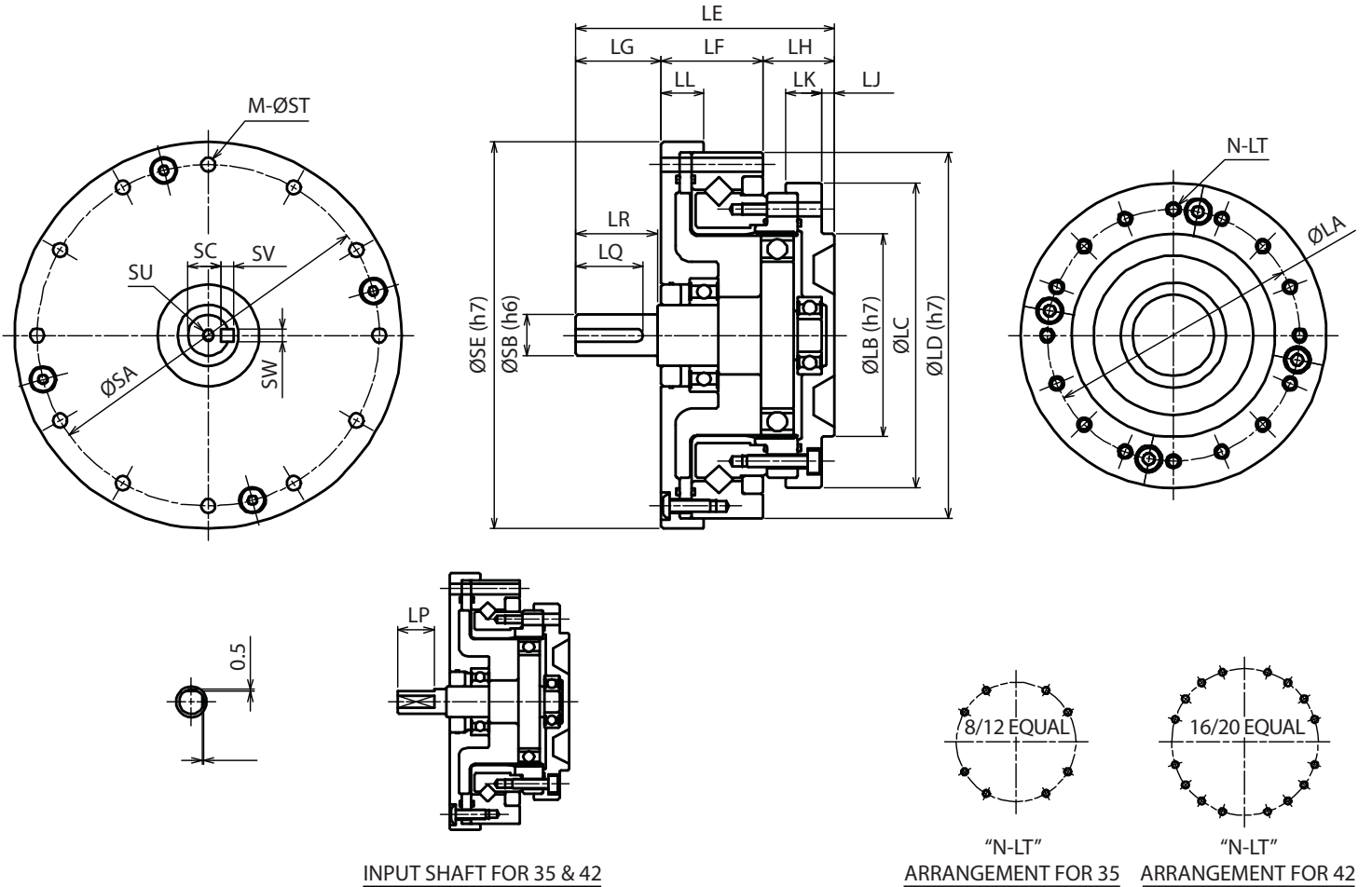

Size	LA	LB	LC	LD	LE	LF	LG	LH	LJ	LK	LL	LP	LQ	LR
35	44	36	54	70	50.5	20.5	15	15	2.5	8	9	11	-	-
42	54	45	64	80	56	23	17	16	3	8.5	10	12	-	-
50	62	50	75	90	63.5	25	21	17.5	3	9	10.5	-	16.5	20
63	77	60	90	110	72.5	26	26	20.5	3	8.5	10.5	-	22.5	25
80	100	85	115	142	84.5	32	26	26.5	5	9.5	12	-	22.5	25

Size	SA	SB	SC	SE	SV	SW	M	ST	SU	N	LT
35	64	6	-	74	-	-	8	3.5	M3	8	M3×5, φ3.5×11.5
42	74	8	-	84	-	-	12	3.5	M3	16	M3×6, φ3.5×12
50	84	10	8.2	95	3	3	12	3.5	M3×6	16	M3×6, φ3.5×13.5
63	102	14	11	115	5	5	12	4.5	M3×6	16	M4×7, φ4.5×15.5
80	132	14	11	147	5	5	12	5.5	M3×6	16	M5×8, φ5.5×20.5



NIDEC-SHIMPO CORPORATION

1701 Glenlake Avenue, Itasca, IL 60143 USA
Phone: (800) 842-1479 • Fax: (630) 924-7382
www.drives.nidec-shimpo.com

